

# Owner's Manual & Assembly Instructions

DA01a

## PATIO COVER/CARPORT

Model No. CP1010□

Freestanding

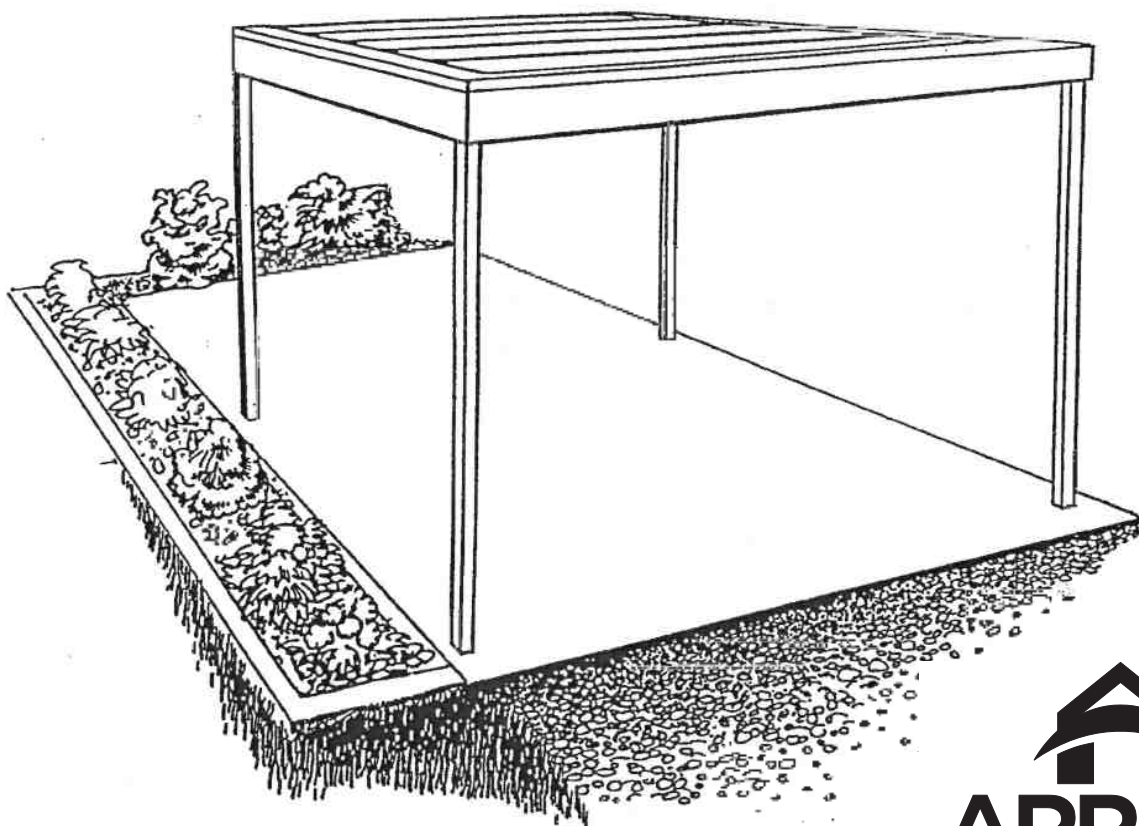

**CAUTION: SOME PARTS HAVE SHARP EDGES. CARE MUST BE TAKEN WHEN HANDLING THE VARIOUS PIECES TO AVOID MISHAP. FOR SAFETY SAKE, PLEASE READ SAFETY INFORMATION PROVIDED IN THIS MANUAL BEFORE BEGINNING CONSTRUCTION. WEAR GLOVES WHEN HANDLING METAL PARTS.**



705210919

**UNIT DIMENSIONS** \*Size rounded off to the nearest foot

*Approx. Size	Foundation Size	Storage Area Sq. Ft. Cu. Ft.		Exterior Dimensions (Roof Edge to Roof Edge)			Interior Dimensions (Facia to Facia)		
				Width	Depth	Height	Width	Depth	Height
10' x 10'	126" x 130 1/4"	98	755	120 7/8"	121 1/2"	96"	118"	119 1/4"	91 1/2"

- GB:** Assembly manual in additional languages available online.  
Scan QR code below to access.
- FR:** Manuel de montage disponible en ligne dans d'autres langues.  
Pour y accéder, scannez le code QR ci-dessous.
- SP:** Manual de montaje en idiomas adicionales disponible online.  
Escanee el código QR a continuación para acceder.
- DE:** Montageanleitung in zusätzlichen Sprachen online verfügbar.  
Scannen Sie den QR-Code unten, um darauf zuzugreifen.
- IT:** Manuale dell'assemblea in altre lingue disponibile online.  
Per accedere effettua la scansione del codice QR in basso.
- PT:** Manual de montagem disponível em outros idiomas online.  
Digitalize o código QR abaixo para obter acesso.
- DT:** Samlingshåndbog i yderligere sprog til rådighed online.  
Scan QR kode nedenunder for at få adgang.
- SK:** Na internete je k dispozícii návod na zostavenie v ďalších jazykoch.  
Dostanete sa k nemu naskenovaním kódu QR.
- CZ:** Návod k montáži v dalších jazycích je k dispozici v online verzi.  
Přístup získáte po naskenování QR kódu níže.
- HU:** Az összeszerelési útmutató további nyelveken is elérhető online.  
A hozzáféréshez olvassa be az alábbi QR-kódot.
- GR:** Υπάρχει διαθέσιμο στο διαδίκτυο το εγχειρίδιο συναρμολόγησης  
σε περισσότερες γλώσσες. Σαρώστε τον παρακάτω κώδικα  
QR για να αποκτήσετε πρόσβαση.

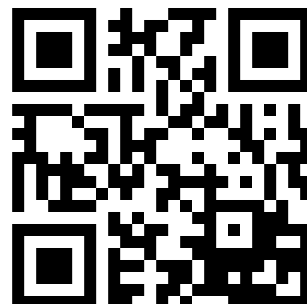

# BEFORE YOU BEGIN...

A03

## Owner's Manual

Before beginning construction, check local building codes regarding footings, location and other requirements. Study and understand this owner's manual.

Important information and helpful tips will make your construction easier and more enjoyable.

**Assembly Instructions:** Instructions are supplied in this manual and contain all appropriate information for your building model. Review all instructions before you begin, and during assembly, follow the step sequence carefully for successful results.

**Flooring and Anchoring:** Your storage building must be anchored to prevent wind damage. A base is necessary to construct a square and level building. Anchoring and base materials are not included with your building. We recommend the combined use of an Arrow Floor Frame Kit and an Arrow Anchoring Kit as an effective method of securing your building to the ground (Available at your local dealer, Arrow's website [arrowsheds.com](http://arrowsheds.com) or call Arrow's Customer Service department 1-800-851-1085) or you may construct a base and anchoring system of your choice. Your assembly instructions provide information on a few methods commonly used to secure and level a storage building.

**Parts and Parts List:** Check to be sure that you have all the necessary parts for your building.

- All part numbers can be found on the parts. All of these numbers (before the -) must agree with the numbers on the Parts List page.

- If you find that a part is missing, include the model number of your building and contact:

Arrow Shed, LLC                      Customer Service Department

1101 North 4th Street      Breese, Illinois 62230

1-800-851-1085 or [assist@arrowsheds.com](mailto:assist@arrowsheds.com)

- Separate contents of the carton by the part number while reviewing parts list. The first few steps show how to join related parts to make larger sub assemblies which will be used later.

- Familiarize yourself with the hardware and fasteners for easier use during construction. These are packaged within the carton. Note that extra fasteners have been supplied for your convenience.

# PLAN AHEAD....

A04

**Watch the Weather:** Be sure the day you select to install your building is dry and calm. Do not attempt to assemble your building on a windy day. Be careful on wet or muddy ground.

**Teamwork:** Whenever possible, two or more people should work together to assemble your building. One person can position parts or panels while the other is able to handle the fasteners and the tools.

**Tools and Materials:** These are some basic tools and materials you will need for the construction of your building. Decide which method of anchoring and the type of base you wish to use in order to form a complete list of the materials you will need.

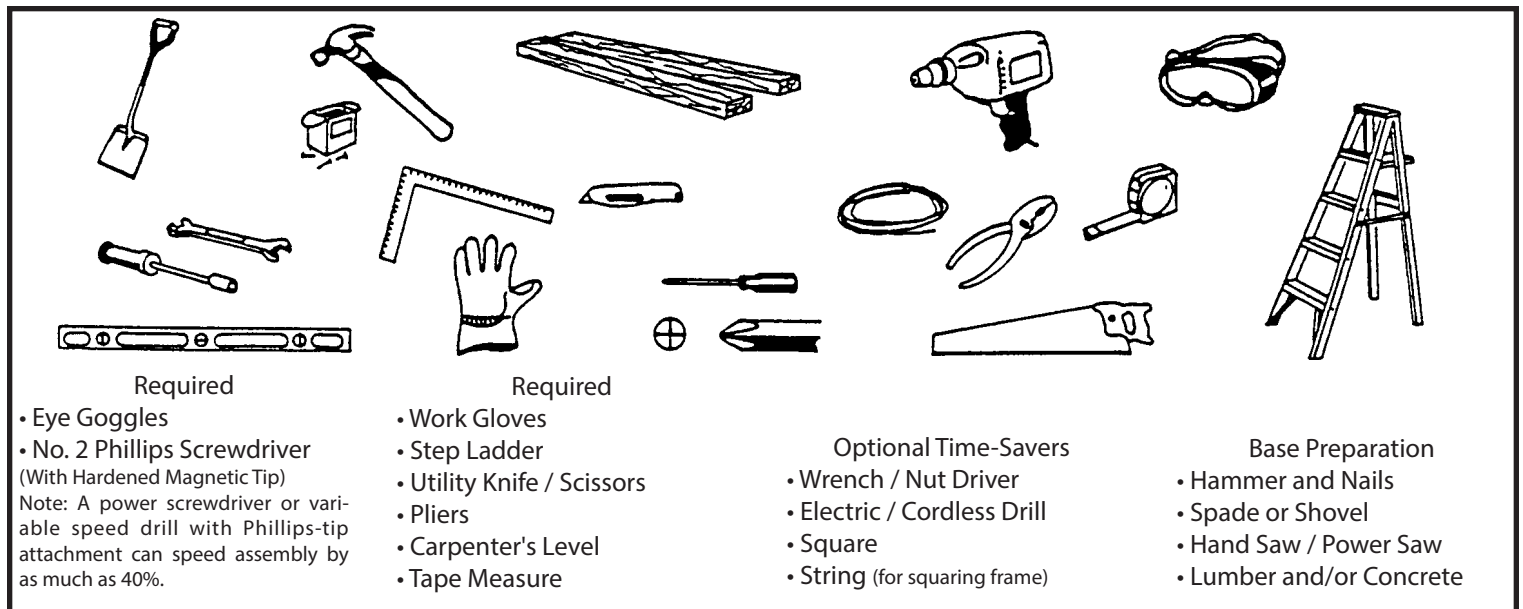

**Selecting and Preparing Your Site:** Before assembly, you will want to decide on a location for your building. The best location is a level area with good drainage.

- Allow enough working space for ease of moving parts into position during assembly. Be sure there will be enough space at entrance for doors to open fully and enough space around the building to be able to fasten the panel screws from the outside.

- Before you begin the first steps in assembling your parts, a base should be constructed and an anchoring system should be ready to use.

# SAFETY FIRST...

A05

Safety precautions are important to follow throughout the construction of your building.

•Care must be taken when handling various pieces of your building since some contain sharp edges. Please wear work gloves, eye protection and long sleeves when assembling or performing any maintenance on your building.

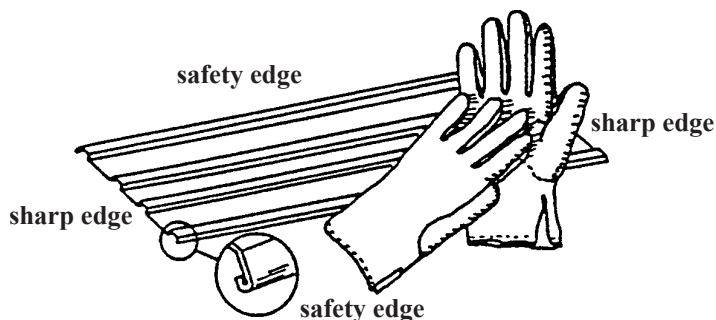

•Keep children and pets away from worksite to avoid distractions and any accidents which may occur.



•Never concentrate your total weight on the roof of the building. When using a step ladder make sure that it is fully open and on even ground before climbing on it.

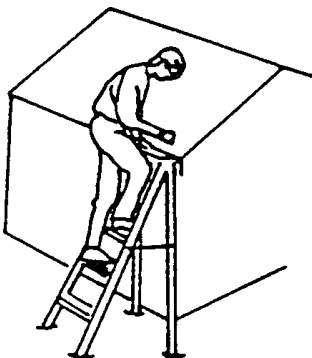

•Practice caution with the tools being used in the assembly of this building. Be familiar with the operation of all power tools.

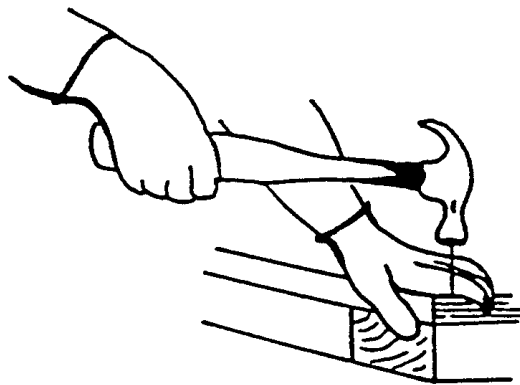

•Do not attempt to assemble the building if parts are missing because any building left partially assembled may be seriously damaged by light winds. Call 1-800-851-1085 or [assist@arrowsheds.com](mailto:assist@arrowsheds.com)

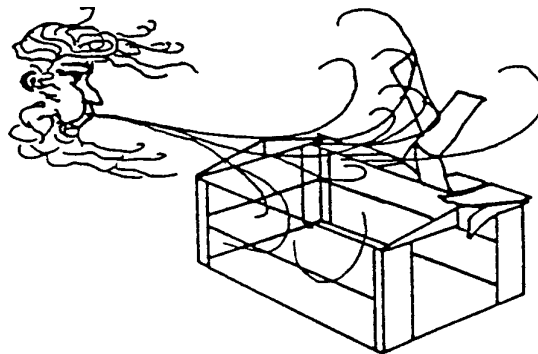

•Do not attempt to assemble the building on a windy day, because the large panels acting as a "sail", can be whipped about by the wind making construction difficult and unsafe.

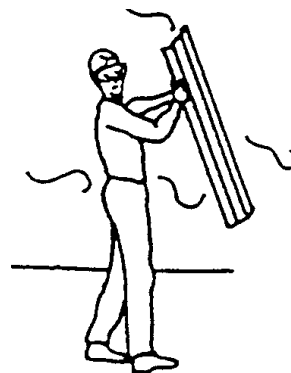

# CARE & MAINTENANCE....

DA05

**Finish:** For long lasting finish, periodically clean and wax the exterior surface. Touch-up scratches as soon as you notice them on your unit. Immediately clean the area with a wire brush; wash it and apply touch-up paint per manufacturer's recommendation.

**Roof:** Keep roof clear of leaves and snow with long handled, soft-bristled broom. Heavy amounts of snow on roof may damage the unit, making it unsafe.

**Fasteners:** Regularly check your unit for loose screws, bolts, nuts, etc. and retighten them as necessary.

## Other Tips....

- Wash off inked part numbers on coated panels with soap and water.

Keep this Owner's Manual and Assembly Instructions for future reference.



# Foundation Recommendations

DA06

## The Foundation For Your Patio Cover/Carport

Note: Before beginning construction, check local building codes regarding footings, location and other requirements.

### REQUIRED: Concrete Footings All concrete minimum 2500 P.S.I.

Footing Bearing is based on soil pressures not to exceed 1,000 P.S.F.

Footing Depth to extend to below frost line but not less than 12".

Whether or not a concrete slab is used, the posts must be anchored in footings.

To locate footing, follow diagram below. Dig footing the minimum dimensions shown. Be sure footings are level with each other, but offset for 2 1/2" slope from rear to front. See Step 3.

Dimensions may vary depending on your soil conditions, consult local codes for footing requirements.

Using 3/4" thick boards, frame footings. The board height will be the height required to make sure the footings and concrete slab (if used) are level with each other. Pour concrete in pre-footing. The remainder of concrete will be poured after the construction of your unit. Allow concrete to cure 24 hours before proceeding.

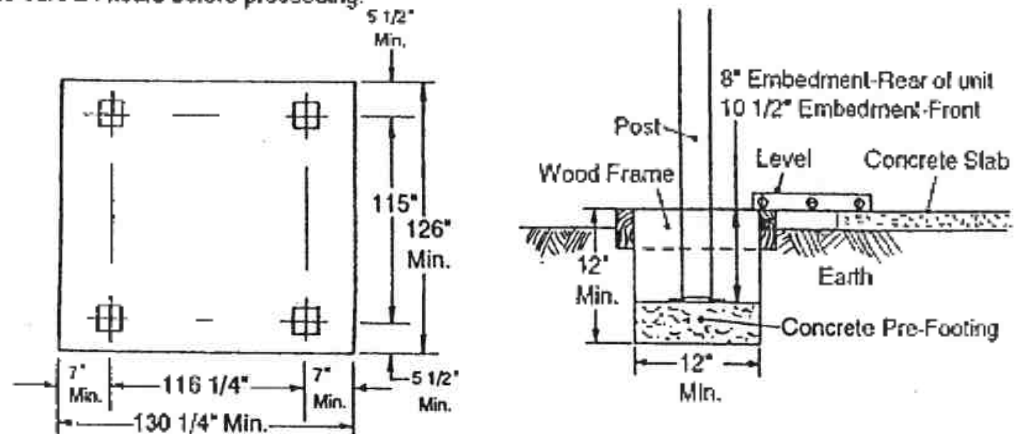

### OPTIONAL: Concrete Slab to be poured after construction of your unit. All concrete minimum 2500 P. S. I.

The slab should be at least 4" thick. It must be level and flat.

The following are the recommended materials for your foundation.

- 2 x 4's (will be removed once the concrete cures)
- Concrete ● Sheet of 6 mil plastic ● 6x6 reinforcing mesh ● sand ● gravel

#### Prepare the Site/Construct a Foundation

1. Dig a rectangle, 10" deep into the ground (remove grass).  
Note: Finished Slab dimensions, with lumber removed.
2. Fill up to 4" in the square with gravel, 2" of sand, and tamp firm.
3. Cover sand with a sheet of 6 mil plastic.
4. Construct a wood frame using 2 x 4 lumber. Make reinforcing stakes.
5. Pour in concrete to fill in the hole and the frame giving a total of 4" thick concrete. Use reinforcing mesh in embedded concrete. Be sure surface is level.

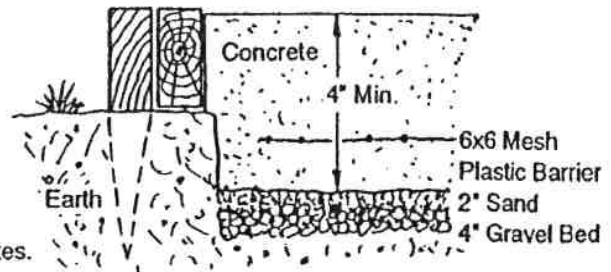

Allow 5 - 8 hours for construction, and a week to harden before driving on.

# Hardware

DA07a



66623  
#10-32x3/8" Screw (94)



66433  
3/8-16 Hex Nut (4)  
(Packed with Screws)



66629  
3/8-16x3 1/4" Hex Hd Bolt (4)



66625  
#10-32x3/4" Bolt (20)  
(Packed with Screws)



66628  
#10-32x7/16" Bolt (16)  
(Packed with Screws)



65106  
#10-32 Square Nut (16)  
(Packed with Screws)



66624  
#10-32 Well-Nut (20)  
(Packed with Screws)

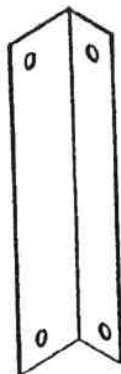

9670-1471  
Corner Trim (4)

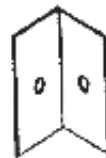

9655-1471  
Top Trim Cap (4)



# Parts List

DA08a

## Parts in Carton One

Assembly Key No.	Part Number	Part Description	Quantity in Carton	Check List
1	9654-1471	Right Facia	1	
2	9657-1471	Left Facia	1	
3	9664-1471	Top Front Trim	1	
4	9667-1471	Top Left End Trim	1	
5	9668-1471	Top Right End Trim	1	
6	9658-1471	End Roof Channel	2	
7	9672-1471	Top Rear Trim	1	
8	9652	Anchor Bracket	4	
9	9733-1471	Front Roof Channel	2	
10	9732-1471	Front Facia	2	
11	9661-1471	Left Post	2	
12	9660-1471	Right Post	2	

## Parts in Carton Two

Assembly Key No.	Part Number	Part Description	Quantity in Carton	Check List
13	9662-1471	Right Roof Panel	1	
14	9663-1471	Left Roof Panel	1	
15	9653-1471	Main Roof Panel	3	

# Assembly by Key No.

DA09

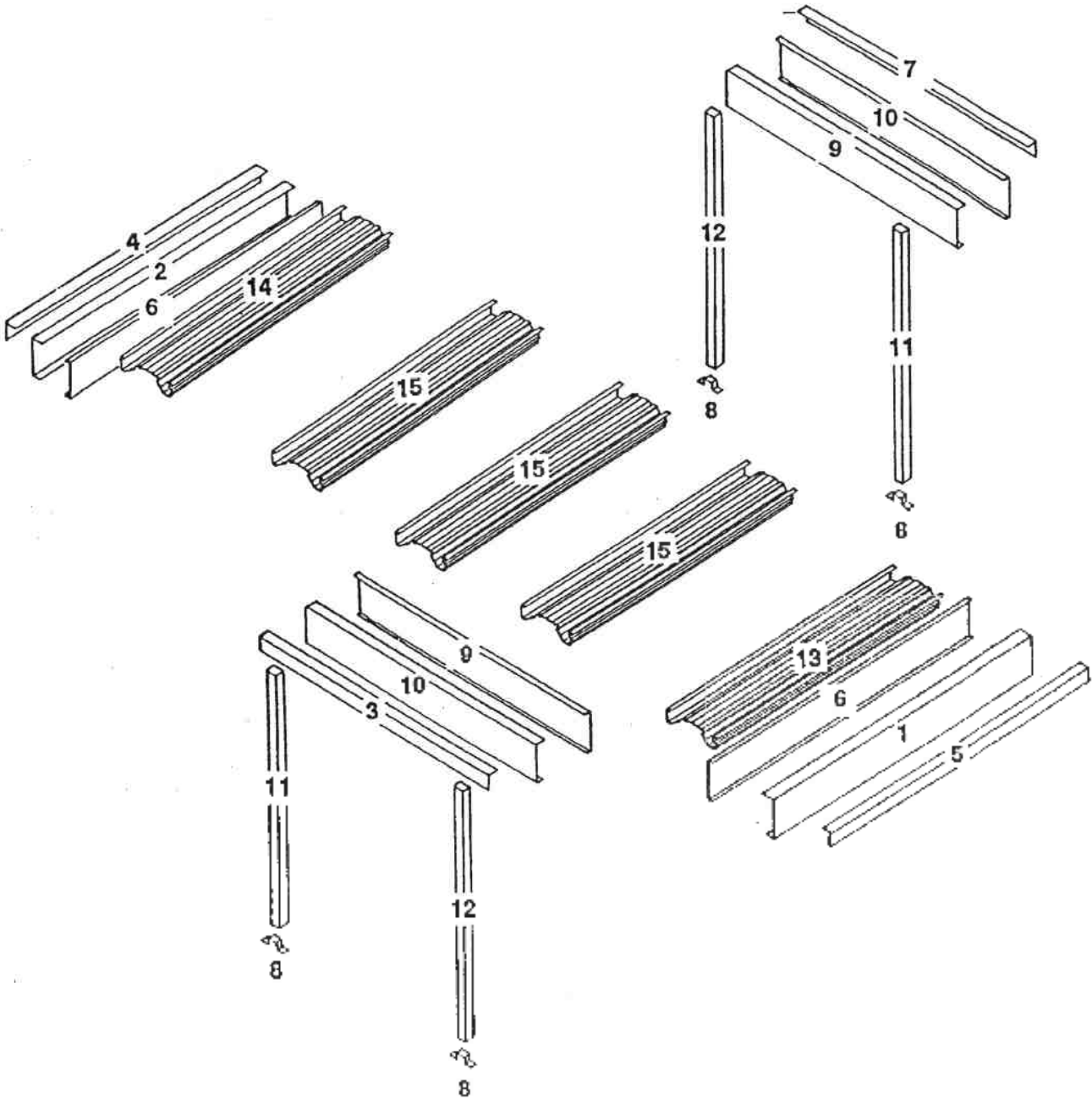

# Step 1

DA10a

## ● Parts Needed For ● Post Pre-Assemblies

- 9661-1471 Left Post (2)
- 9660-1471 Right Post (2)
- 9652 Anchor Bracket (4)

The anchor brackets in this step will be used later to anchor the unit to the pre-footing.

**1** Position an anchor bracket inside the left, & right posts, align holes, and fasten using a 3/8-16x 3 1/4" hex head bolt and hex nut. Make four assemblies. Do not over-tighten.

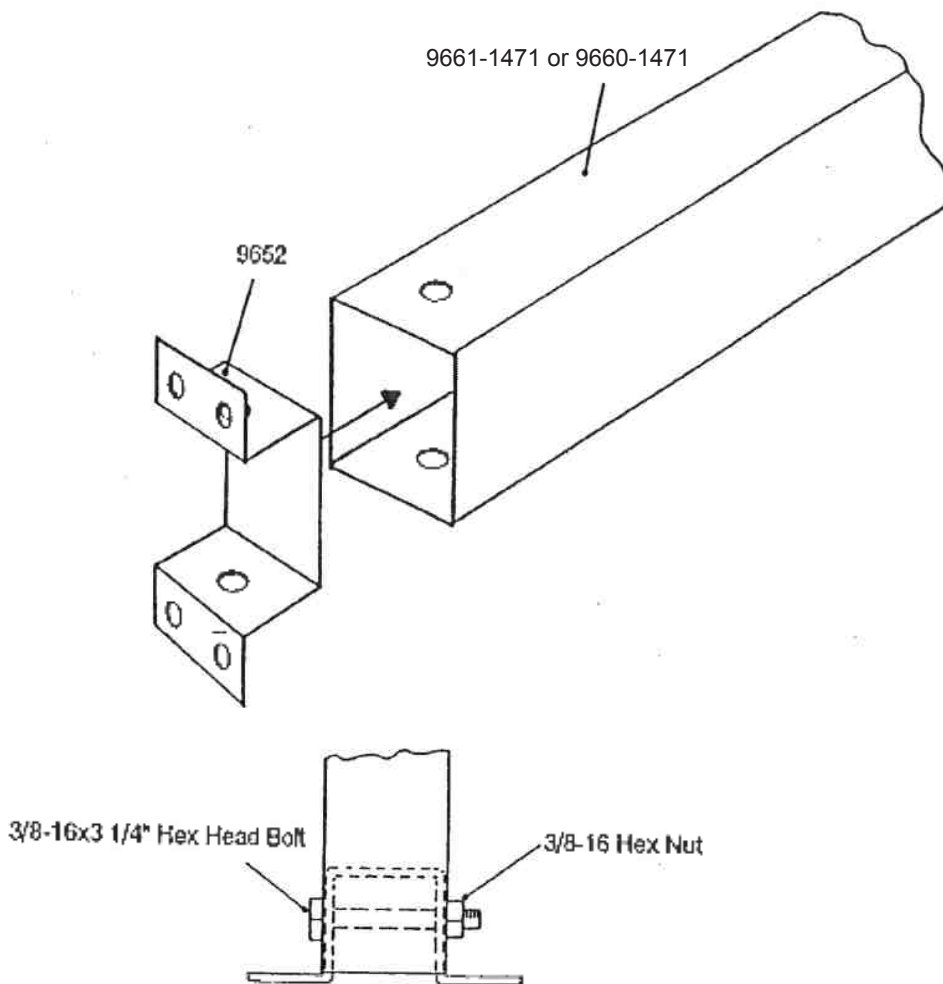

# Step 2

DA11a

- Parts Needed For ●
- 9733-1471 Front Roof Channel (2)
  - 9661-1471 Left Post (2)
  - 9660-1471 Right Post (2)
- ## Front Roof Channel/ Post Assembly

**1** Fasten a front roof channel to the top end of the left post, with most holes in flange on top, noting location of lock seam, using two #10-32x7/16" bolts and square nuts, and two #10Ax3/8" screws. Position other end overlapping right post, fasten as before.

**2** Make two complete assemblies.

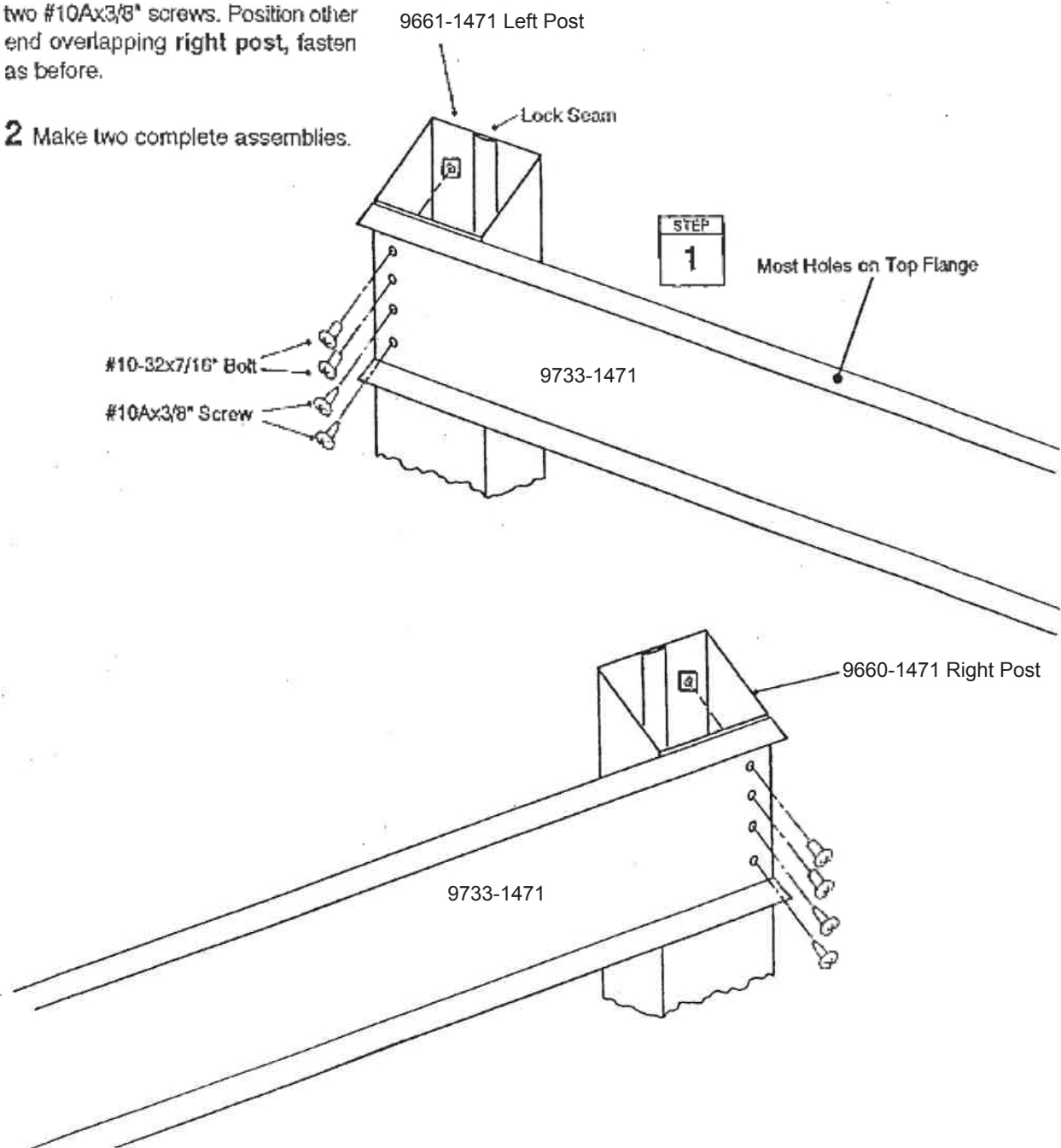

# Step 3

DA12

● Parts Needed For ●  
**Post Set-Up**

● Post/Roof Channel Assembly (2)

1 Set posts into holes and brace with 2x4's as shown. Make sure that the roof channels and posts are level. Provide for proper slope of  $2\frac{1}{2}^{\circ}$ .

Remove the six cross braces, one at a time, as you install the roof panels in a later step.

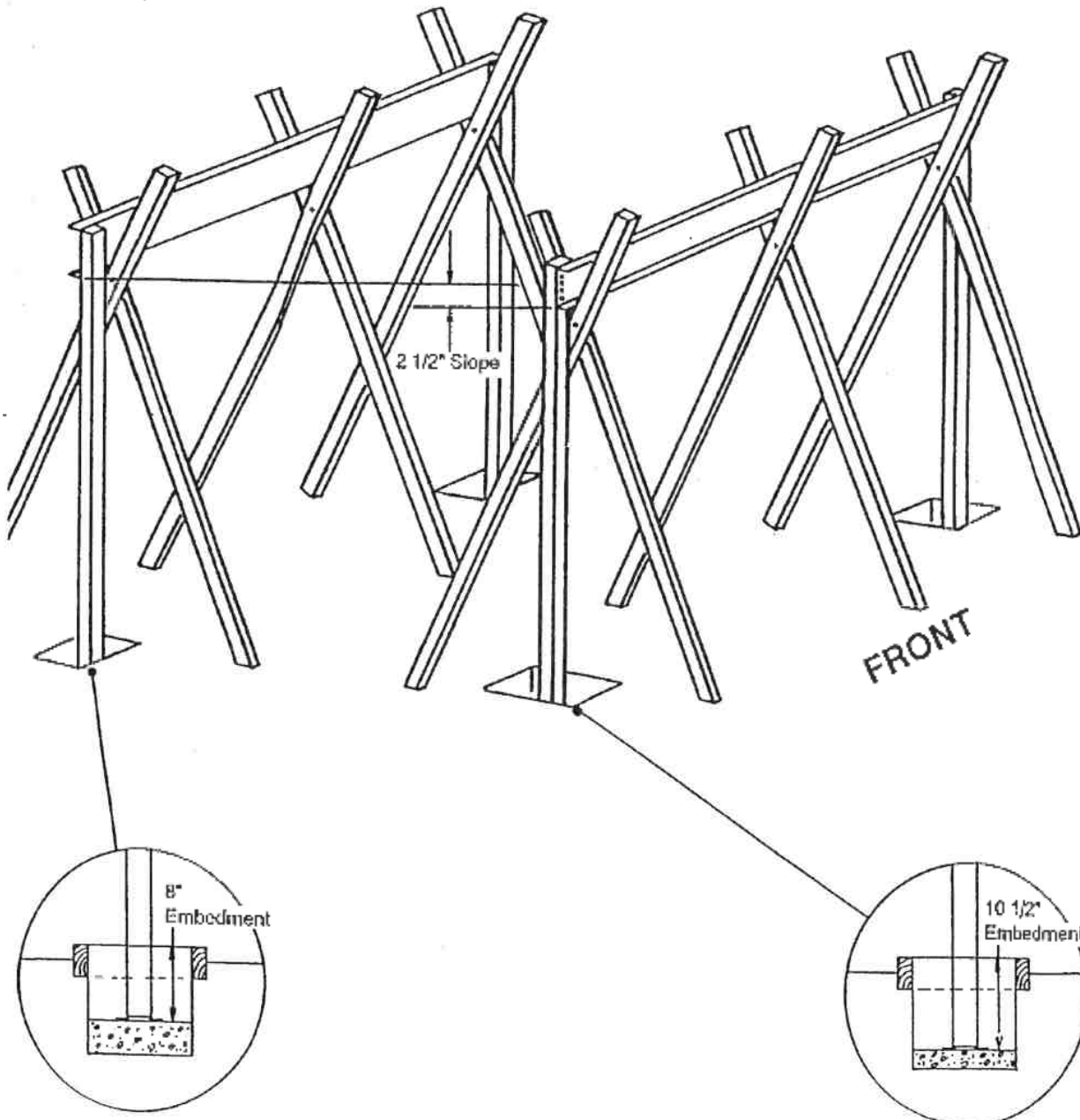

# Step 4

DA13a

## ● Parts Needed For ● End Roof Channel Assembly

- 9658-1471 End Roof Channel (2)

**1** Fasten an end roof channel to the top end of the **right post** using two #10-32x7/16" bolts and square nuts, and two #10Ax3/8" screws. Fasten other end to the top end of the **left post**, using the same fasteners.

**2** Repeat procedure on the opposite end of unit.

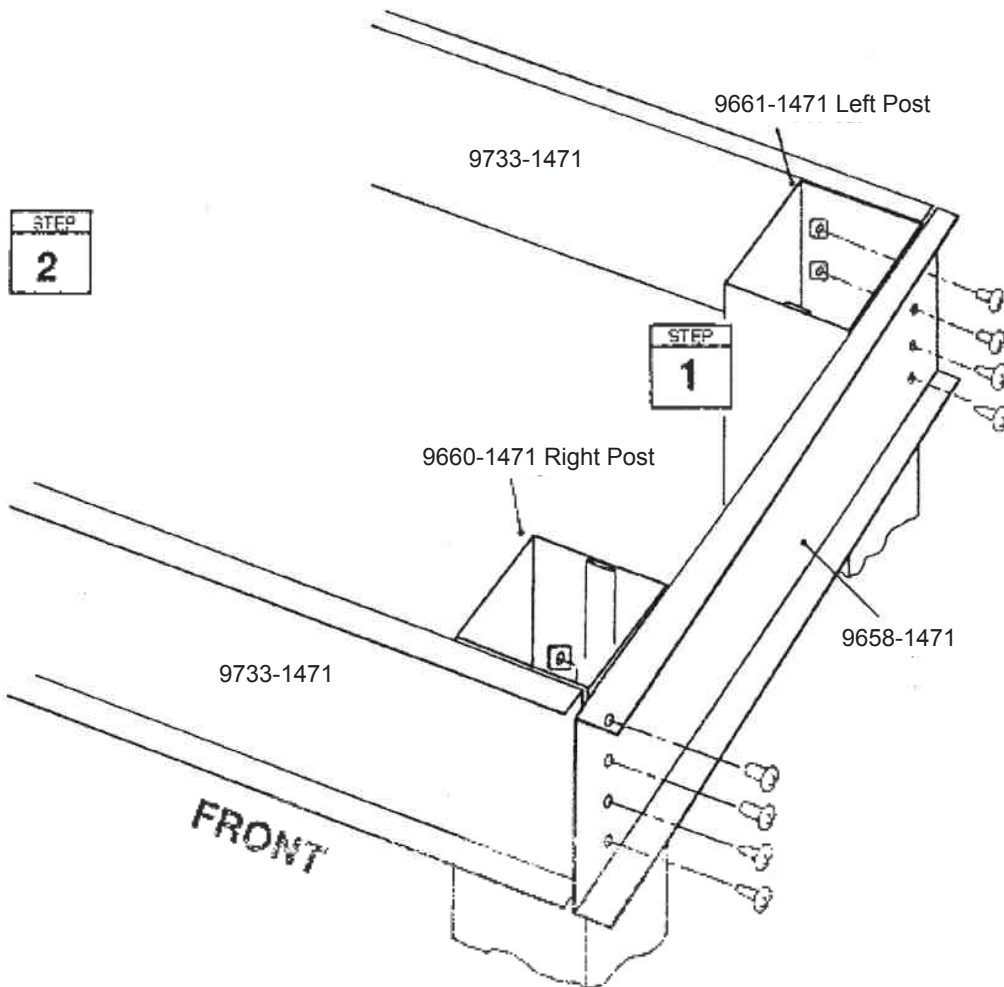
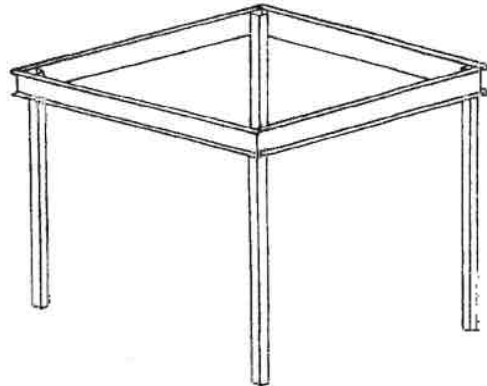



# Step 5

DA14a

## ● Parts Needed For ● Facia Assembly

- 9732-1471 Front Facia (2)
- 9654-1471 Right Facia (1)
- 9657-1471 Left Facia (1)

**1** Place **front facia** over front roof channel with largest amount of holes on top. Butt together and fasten bottom flange with five #10Ax 3/8" screws. Fasten top flange using three #10 screws where shown. Repeat procedure on rear of unit.

**2** Place **right and left facia** over end roof channels. Fasten bottom flange with five #10 screws. Fasten top flange in the same manner.

**3** Place a well-nut on top flange of the front facia. Insert all the way into pre-drilled hole until flange is firmly against mounting surface. Continue along length of the front facia. Repeat procedure on opposite front facia.

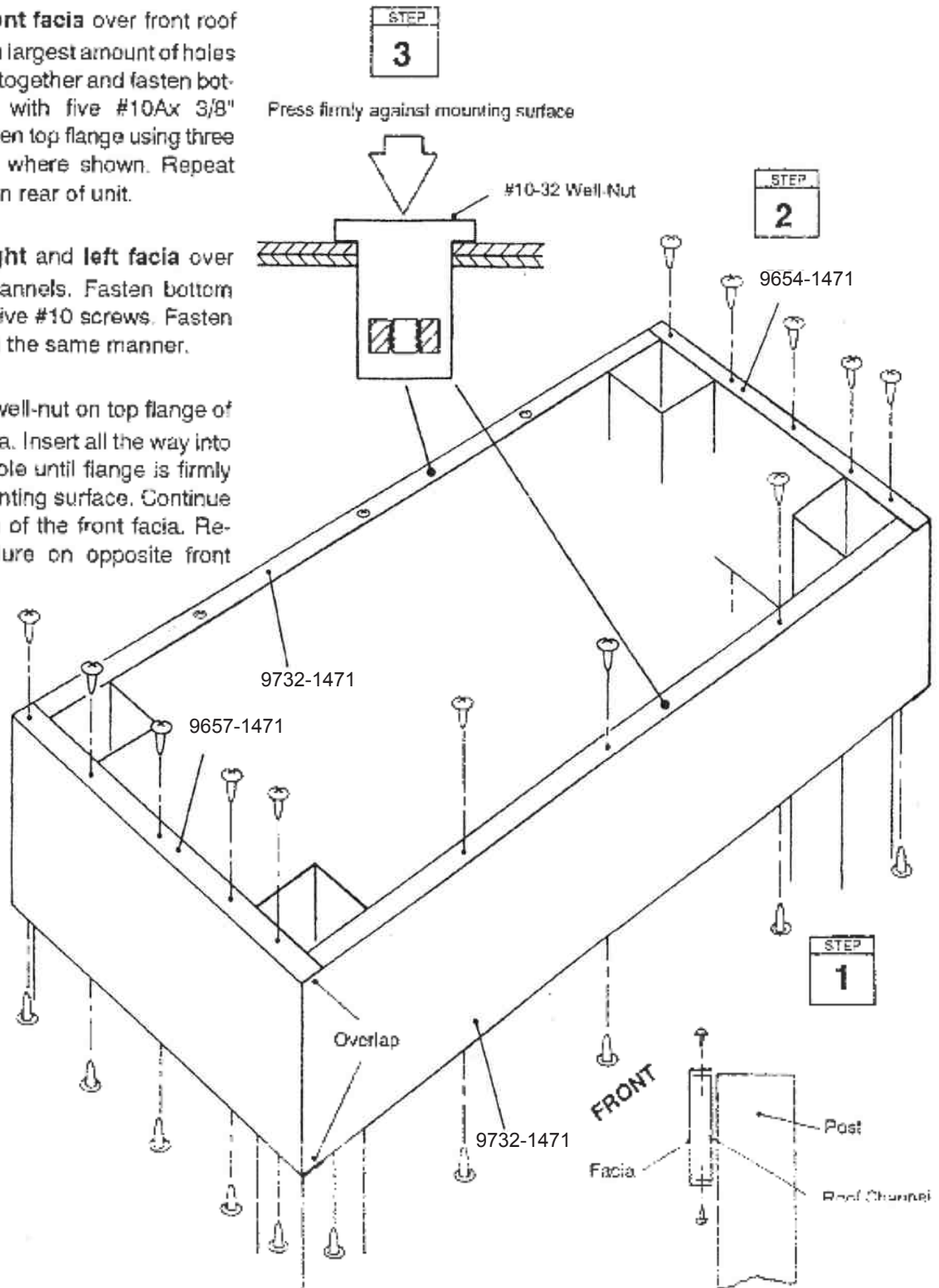

# Step 6

DA15a

## ● Parts Needed For ● Corner Trim

- 9670-1471 Corner Trim (4)

**1** Position **corner trim** to outside corner with long flange on the front fascia, and fasten with four #10 screws. Repeat procedure for other three corners of unit.

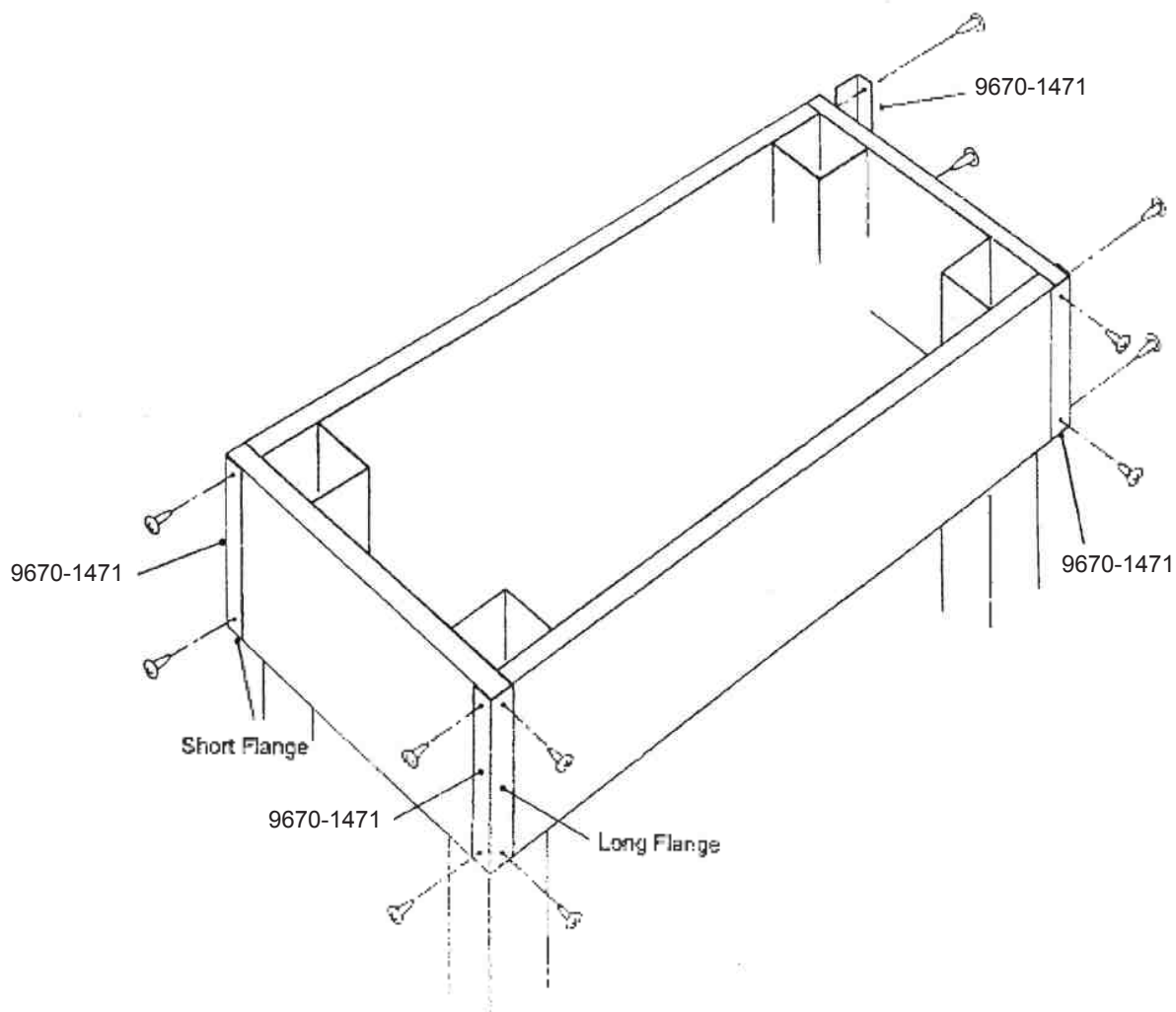
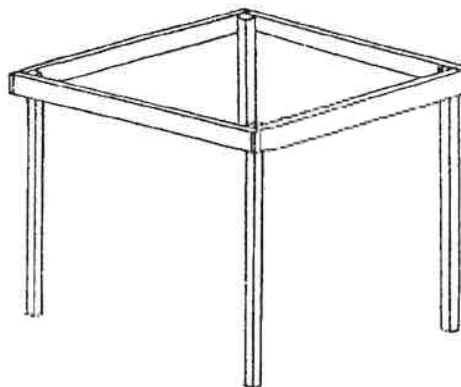

# Step 7

DA16a

## ● Parts Needed For ● Roof Assembly

- 9662-1471 Right Roof Panel (1)
- 9653-1471 Main Roof Panel (3)
- 9663-1471 Left Roof Panel (1)

**1** Fasten top of **right roof panel** using two #10-32x3/4" bolts into rear fascia. Pass bolt through panel and tighten until snug. Do not over-tighten. Fasten bottom of panel in the same manner into front fascia.

### IMPORTANT

2x4's centered under roof panel will help you align the holes

**2** While aligning flush, lock a **main roof panel** and right roof panel together. Be sure entire rib on roof panels are interlocked together.

**3** Fasten top and bottom of panel in the same manner.

**4** Continue installing the remaining two main and the **left roof panel** as before.

To square unit, measure diagonally. Make sure both diagonal measurements are the same. These measurements are taken from opposite ends of front and rear fascia. Measure from the top outside edge of front fascia to the top outside edge of the rear fascia. If diagonal dimensions are not the same, adjust assembled fascia section left to right until the diagonals are equal.

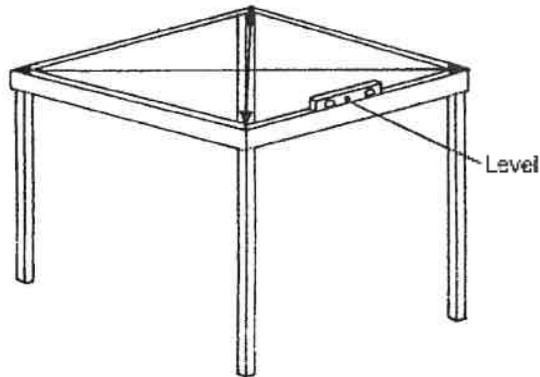

Diagonal Measurement

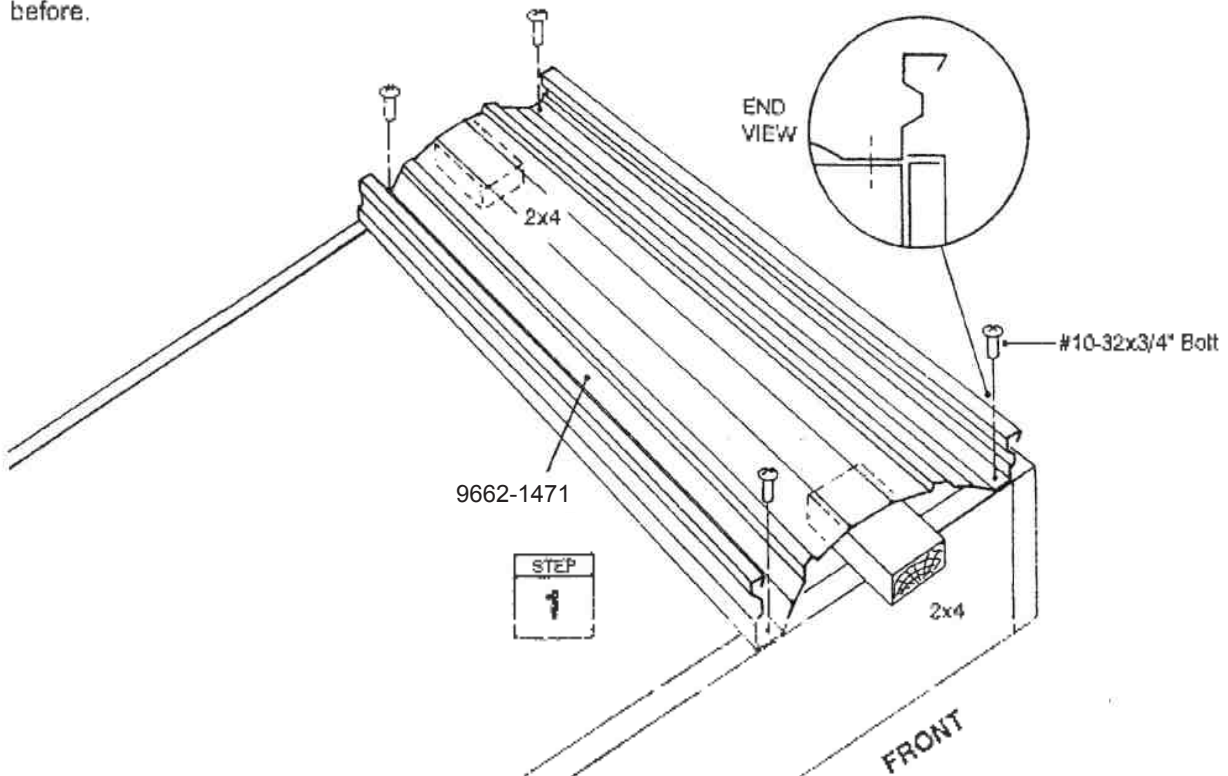

# Step 7 continued....

DA17a

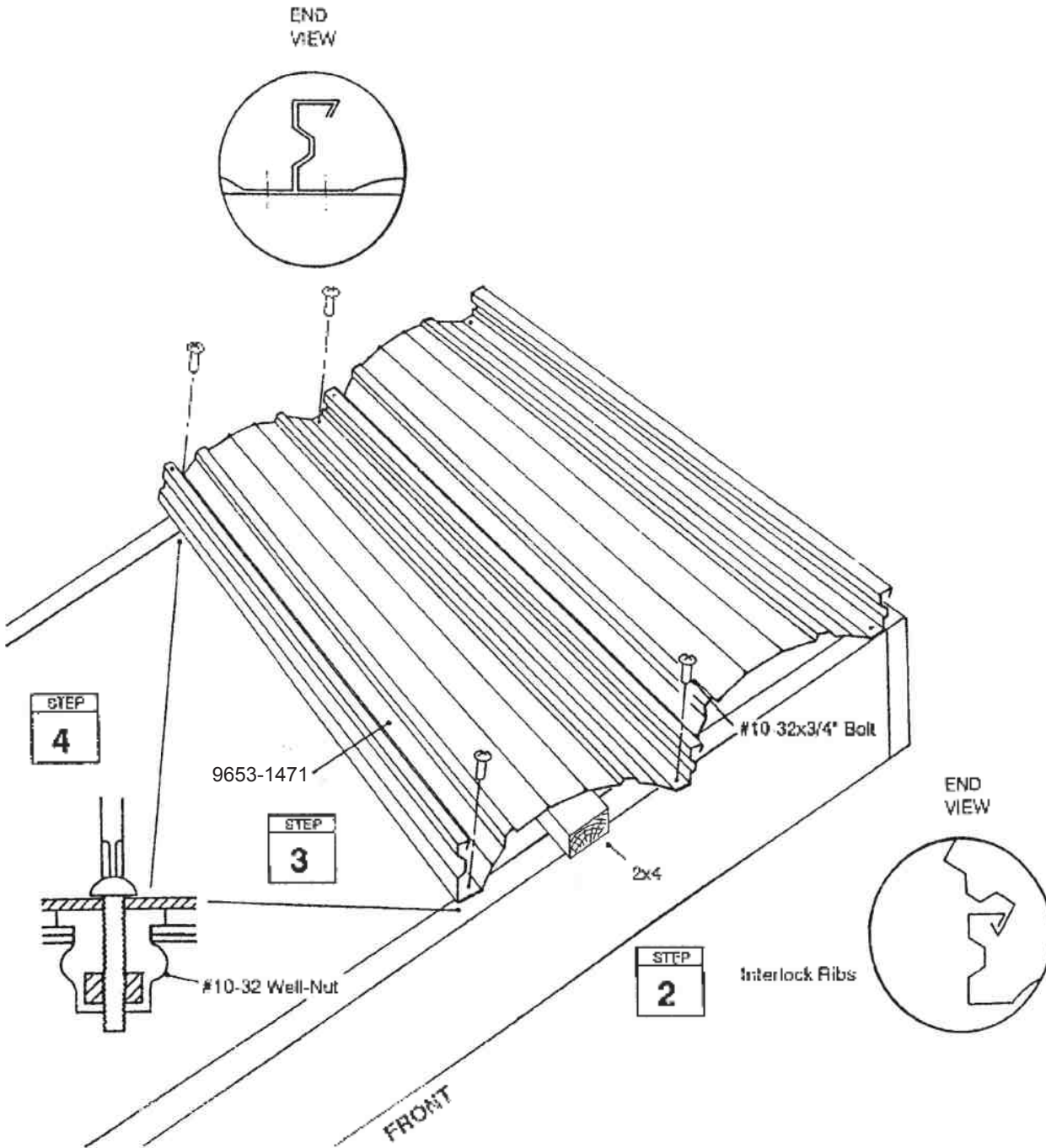

# Step 8

DA18a

## ● Parts Needed For ● Top Left and Right End Trim

- 9667-1471 Top Left End Trim (1)
- 9668-1471 Top Right End Trim (1)

**1** Fasten **top right end trim** to the outer right roof panel rib using three #10Ax3/8" screws. Do not fasten either end until the next step.

**2** Repeat procedure for the **top left end trim** on the outer left roof panel rib.

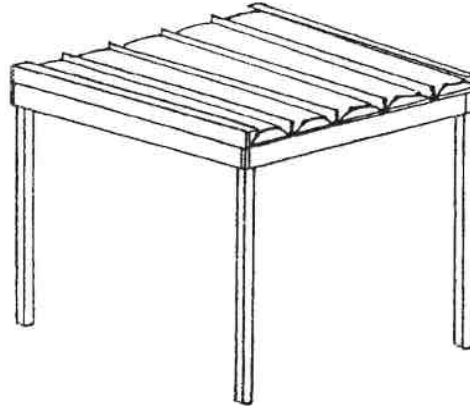

Do not fasten until next step

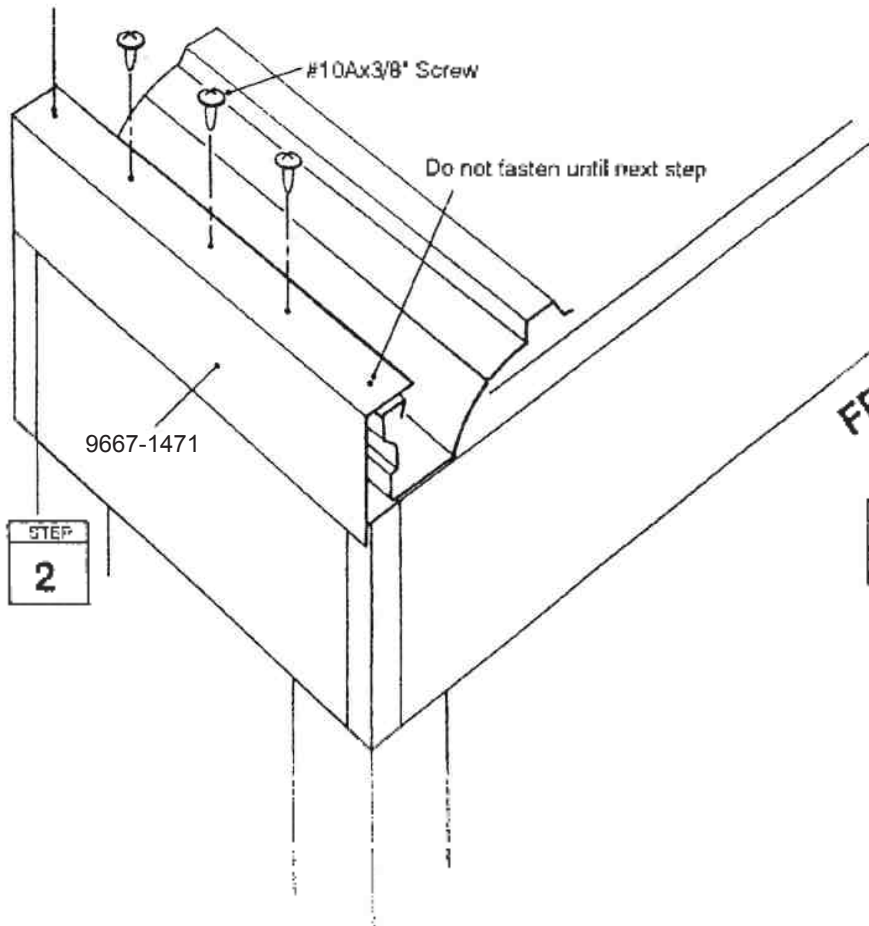

FRONT

STEP  
1

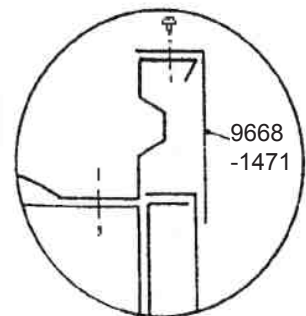

END  
VIEW



# Step 9

DA19a

## ● Parts Needed For ● Top Front / Rear Trim

- 9664-1471 Top Front Trim (1)
- 9672-1471 Top Rear Trim (1)
- 9655-1471 Top Trim Cap (4)

**1** Position **top front trim** to ends of roof panels, overlapping top left and right end trim and fasten using six #10 screws.

**2** Repeat procedure on the rear of unit with **top rear trim** piece.

**3** Cover seams where trims meet at the corners with **top trim caps** using eight screws.

STEP  
2

9672-1471

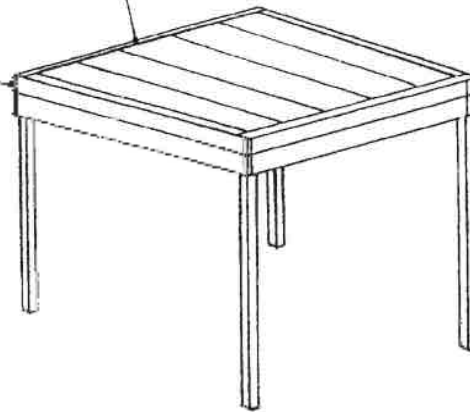

9655

-1471

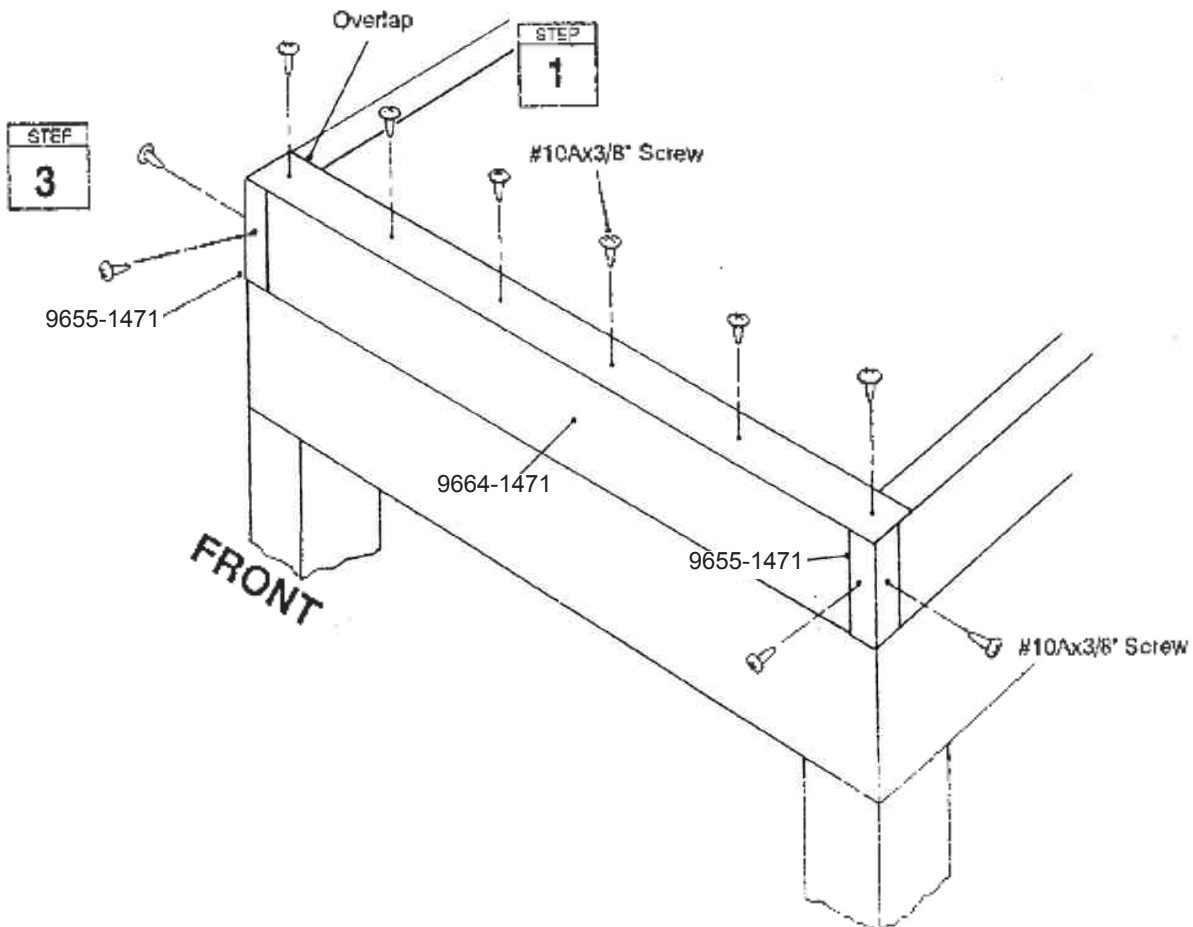



# Step 10 Leveling and Anchoring Posts

DA20

Check to be sure front facia and rear facia are still square. Level each post. Stand at one end and visually check the alignment of the post. Once posts are aligned, mark fastener location using holes in bottom flanges of anchor bracket as a guide.

Using a masonry bit, drill holes to fit masonry fasteners (not provided). Attach bottom flanges of anchor bracket to pre-footing, using instructions packed with masonry fasteners.

Fill in holes with concrete. Pyramid concrete approximately 1" above the ground level to avoid puddling around posts.

Concrete slab can now be poured (if used).

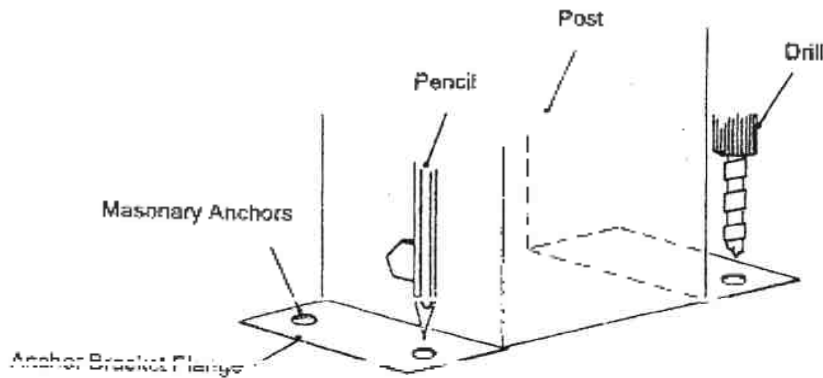
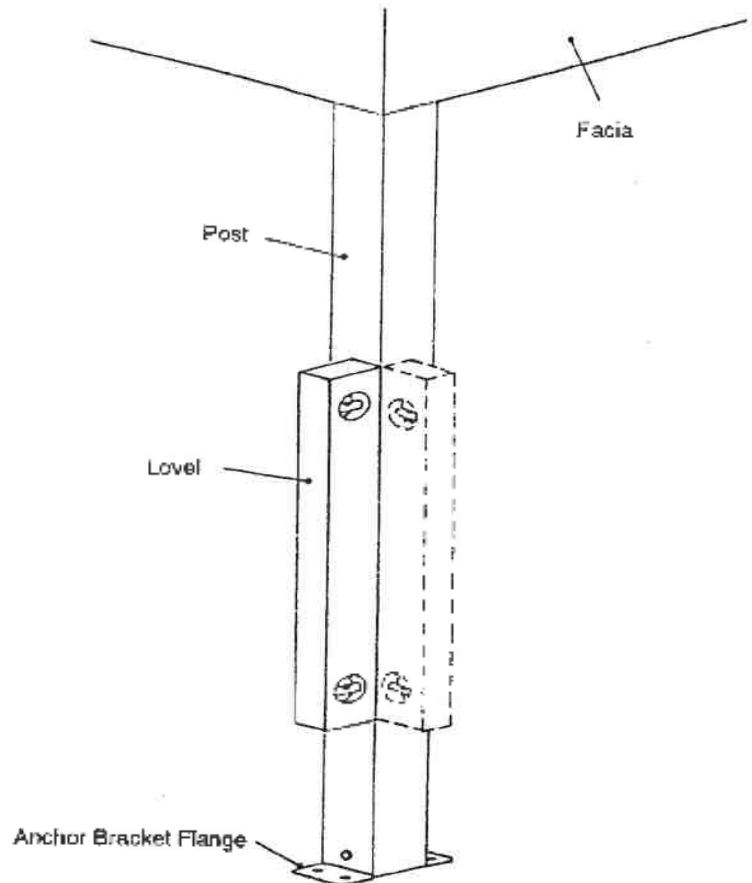
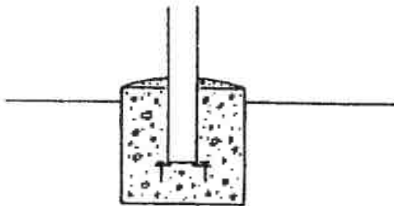

# Suggested Guttering System (not included)

DA21

If the locality where you have installed the patio cover/carport could benefit from a guttering system, we recommend the following list of materials, (not included).

- One 10' gutter
- One downspout
- One outlet
- One right & One left end cap
- Sealant
- Five hidden hangers with five 1 1/2" bolts and nuts
- Three standard elbows
- Two bands with four sheet metal screws

**1** Assemble the gutter on the ground using sealant.

**2** Temporarily remove top front trim, lift assembly to unit and mark top left and right end trim where gutter meets trim. Remove gutter system and notch (using tin snips) top L&R end trim so gutter fits flush along front of unit.

**3** Evenly space out five hidden hangers in gutter, making sure one is in the outlet. Attach gutter assembly to front fascia/ front roof channel using five 1 1/2" bolts and nuts through hidden hangers. Replace top front trim.

**4** Assemble the downspout on the ground.

**5** Hold in place on outlet. Attach to post with two bands. Drill 3/32" holes and fasten with sheet metal screws.

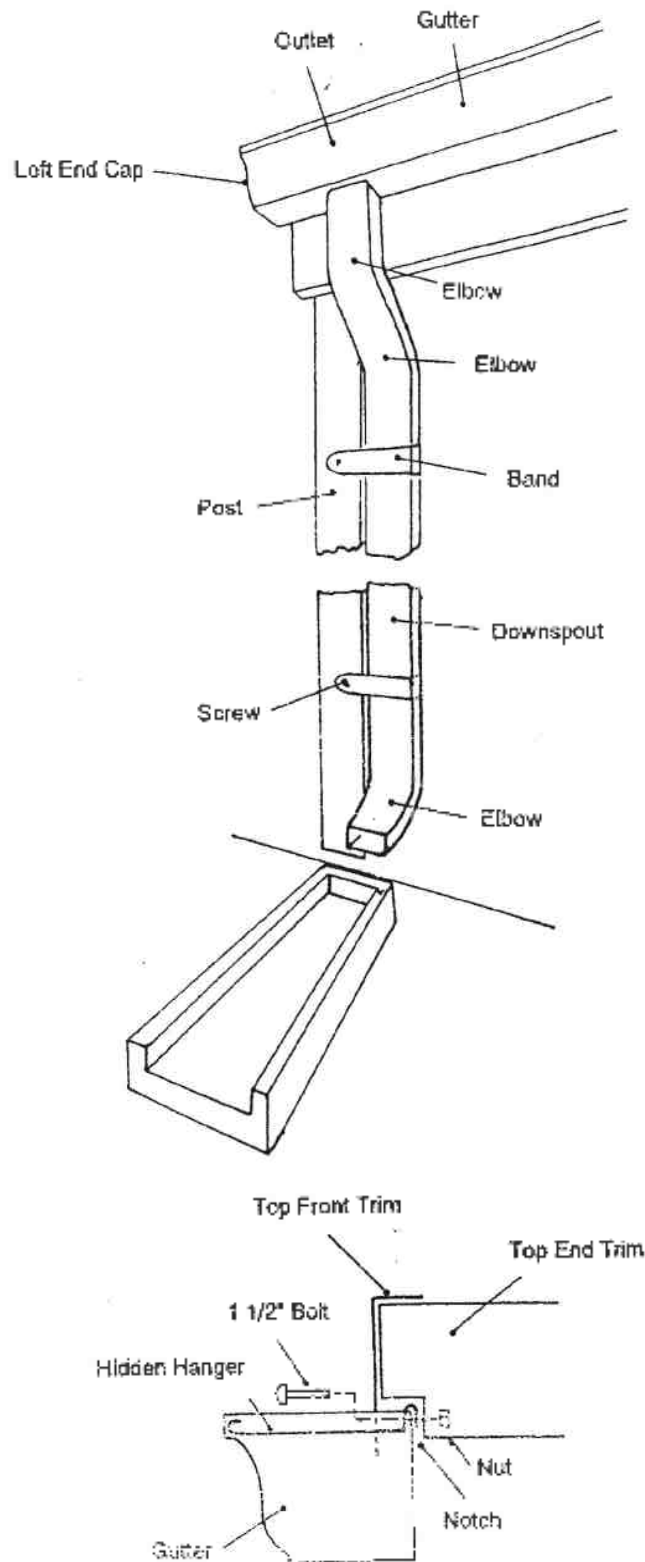



# CP1010□

DA22a

## **SOME FACTS ABOUT RUST**

Rusting is a natural oxidizing process that occurs when bare metal is exposed to moisture. Problem areas include screw holes, unfinished edges, or where scrapes and nicks occur in the protective coating through normal assembly, handling and use. Identifying these natural rusting problem areas and taking some simple rust protection precautions can help to stop rust from developing, or stop it quickly as soon as it appears.

1. Avoid nicking or scraping the coating surface, inside and out.
2. Use all the washers supplied.
3. Keep roof, base perimeter and door tracks free of debris and leaves.
4. Touch up scrapes or nicks and any area of visible rust as soon as possible.

1. Avoid nicking or scraping the coating surface, inside and out.

2. Keep roof and post perimeter free of debris and leaves which may accumulate and retain moisture. These can do double damage since they give off acid as they decay.

3. Touch up scrapes or nicks and any area of visible rust as soon as possible. Make sure the surface is free of moisture, oils, dirt or grime and then apply an even film of high quality touch-up paint.