

Owner's Manual & Assembly Instructions

CJ01

**Model No. EP84 □ PT84 □ PT84EU □
PTG84 □ PTG84EU □ EPA84 □**



**Missing Parts, Questions on Assembly?
Call: 1-800-851-1085 or
assist@arrowsheds.com
Do not return to dealer, they are not
equipped to handle your requests.**

716761217

Storage Area: 28 Sq. Ft. 150 Cu. Ft.
2,6 m² 4,2 m³

BUILDING DIMENSIONS

* Size rounded off to the nearest foot



CAUTION: SOME PARTS HAVE SHARP EDGES. CARE MUST BE TAKEN WHEN HANDLING THE VARIOUS PIECES TO AVOID A MISHAP. FOR SAFETY SAKE, PLEASE READ SAFETY INFORMATION PROVIDED IN THIS MANUAL BEFORE BEGINNING CONSTRUCTION. WEAR GLOVES WHEN HANDLING METAL PARTS.

*Approx. Size	Base Size	Exterior Dimensions (Roof Edge to Roof Edge)			Interior Dimensions (Wall to Wall)			Door Opening	
		Width	Depth	Height	Width	Depth	Height	Width	Height
8' x 4'	97 1/2" x 45 1/4"	100"	47"	67 3/4"	94 3/4"	42 1/2"	66 9/16"	43 1/2"	60"
2,4 m x 1,1 m	247,7 cm x 114,9 cm	254,0 cm	119,4 cm	172,1 cm	240,7 cm	108,0 cm	169,1 cm	110,5 cm	152,4 cm

BEFORE YOU BEGIN...

A03

Owner's Manual

Before beginning construction, check local building codes regarding footings, location and other requirements. Study and understand this owner's manual.

Important information and helpful tips will make your construction easier and more enjoyable.

Assembly Instructions: Instructions are supplied in this manual and contain all appropriate information for your building model. Review all instructions before you begin, and during assembly, follow the step sequence carefully for successful results.

Flooring and Anchoring: Your storage building must be anchored to prevent wind damage. A base is necessary to construct a square and level building. Anchoring and base materials are not included with your building. We recommend the combined use of an Arrow Floor Frame Kit and an Arrow Anchoring Kit as an effective method of securing your building to the ground (Available at your local dealer, Arrow's website arrowsheds.com or call Arrow's Customer Service department 1-800-851-1085) or you may construct a base and anchoring system of your choice. Your assembly instructions provide information on a few methods commonly used to secure and level a storage building.

Parts and Parts List: Check to be sure that you have all the necessary parts for your building.

- All part numbers can be found on the parts. All of these numbers (before the -) must agree with the numbers on the Parts List page.

- If you find that a part is missing, include the model number of your building and contact:

Arrow Shed, LLC Customer Service Department

1101 North 4th Street Breese, Illinois 62230

1-800-851-1085 or assist@arrowsheds.com

- Separate contents of the carton by the part number while reviewing parts list. The first few steps show how to join related parts to make larger sub assemblies which will be used later.

- Familiarize yourself with the hardware and fasteners for easier use during construction. These are packaged within the carton. Note that extra fasteners have been supplied for your convenience.

PLAN AHEAD....

A04

Watch the Weather: Be sure the day you select to install your building is dry and calm. Do not attempt to assemble your building on a windy day. Be careful on wet or muddy ground.

Teamwork: Whenever possible, two or more people should work together to assemble your building. One person can position parts or panels while the other is able to handle the fasteners and the tools.

Tools and Materials: These are some basic tools and materials you will need for the construction of your building. Decide which method of anchoring and the type of base you wish to use in order to form a complete list of the materials you will need.

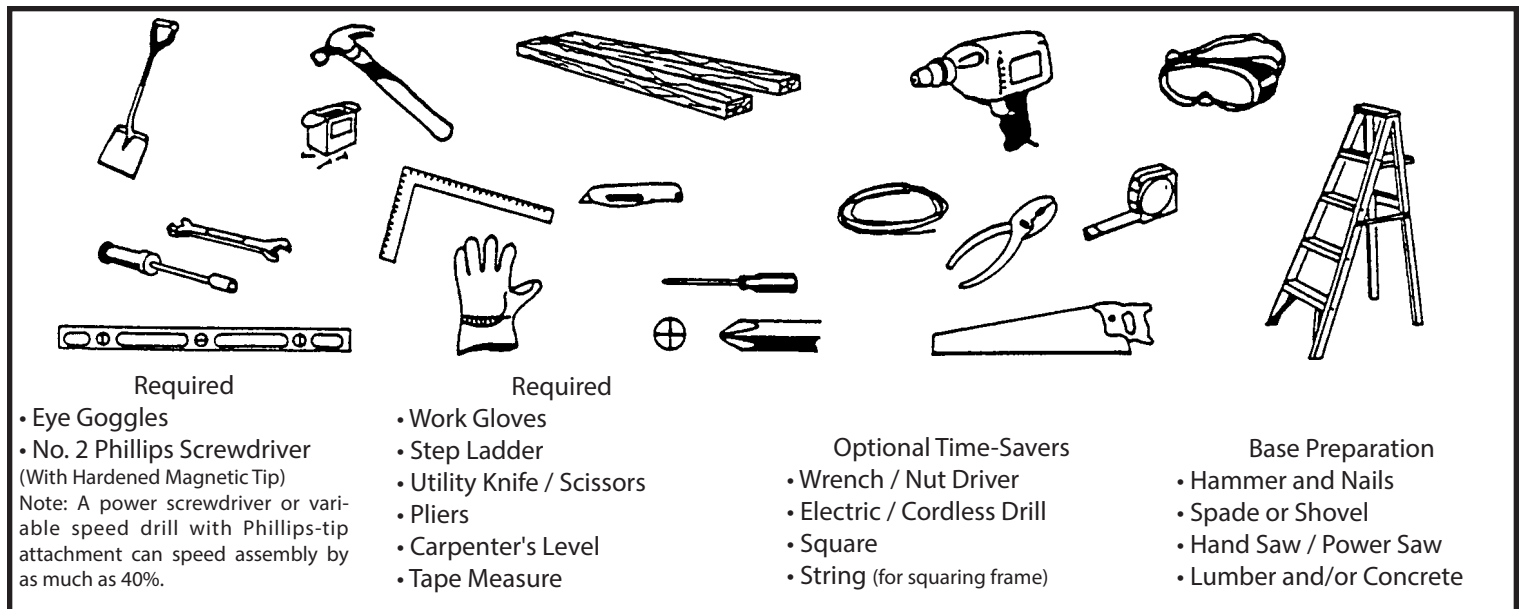

Selecting and Preparing Your Site: Before assembly, you will want to decide on a location for your building. The best location is a level area with good drainage.

- Allow enough working space for ease of moving parts into position during assembly. Be sure there will be enough space at entrance for doors to open fully and enough space around the building to be able to fasten the panel screws from the outside.

- Before you begin the first steps in assembling your parts, a base should be constructed and an anchoring system should be ready to use.

SAFETY FIRST...

Safety precautions are important to follow throughout the construction of your building.

•Care must be taken when handling various pieces of your building since some contain sharp edges. Please wear work gloves, eye protection and long sleeves when assembling or performing any maintenance on your building.

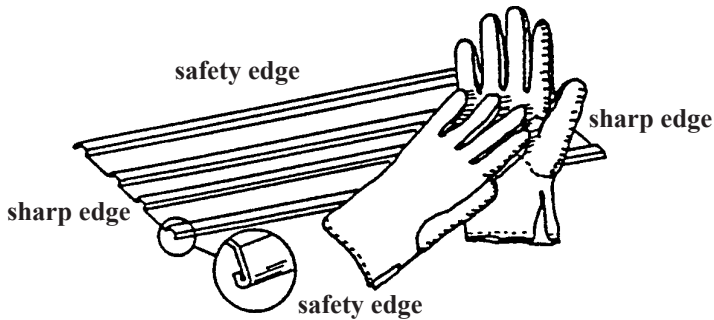

•Keep children and pets away from worksite to avoid distractions and any accidents which may occur.



•Never concentrate your total weight on the roof of the building. When using a step ladder make sure that it is fully open and on even ground before climbing on it.

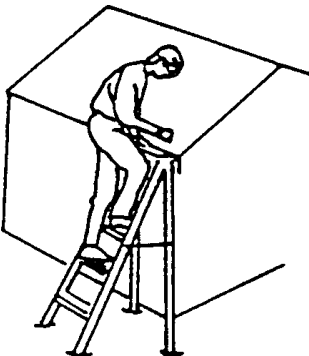

•Practice caution with the tools being used in the assembly of this building. Be familiar with the operation of all power tools.

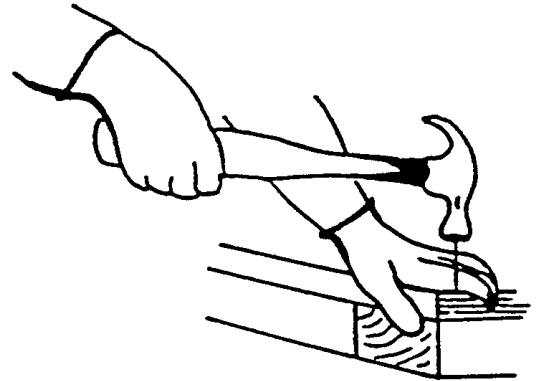

•Do not attempt to assemble the building if parts are missing because any building left partially assembled may be seriously damaged by light winds. Call 1-800-851-1085 or assist@arrowsheds.com

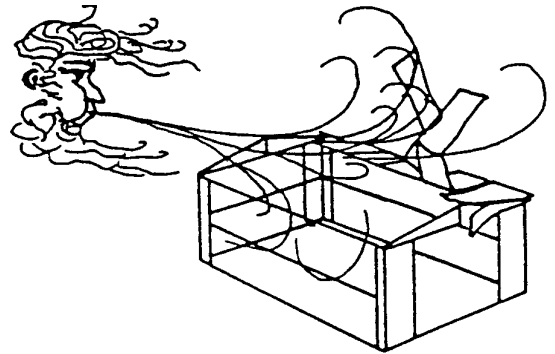

•Do not attempt to assemble the building on a windy day, because the large panels acting as a "sail", can be whipped about by the wind making construction difficult and unsafe.



CARE & MAINTENANCE....

A06

Finish: For long lasting finish, periodically clean and wax the exterior surface. Touch-up scratches as soon as you notice them on your unit. Immediately clean the area with a wire brush; wash it and apply touch-up paint per manufacturer's recommendation.

Roof: Keep roof clear of leaves and snow with long handled, soft-bristled broom. Heavy amounts of snow on roof can damage building making it unsafe to enter. In snow country, Roof Strengthening Kits are available for most Arrow Buildings for added protection against heavy snow accumulation. Contact Arrow as outlined on the Ordering Accessories page to place an order.

Doors: Always keep the door tracks clear of dirt and other debris that prevent them from sliding easily. Lubricate door track annually with furniture polish or silicone spray. Keep doors closed and locked to prevent wind damage.

Fasteners: Use all washers supplied to protect against weather infiltration and to protect the metal from being scratched by screws. Regularly check your building for loose screws, bolts, nuts, etc. and retighten them as necessary.

Moisture: A plastic sheet (vapor barrier) placed under the entire floor area with good ventilation will reduce condensation.

Other Tips....

- Wash off inked part numbers on coated panels with soap and water.
- Silicone caulking may be used for watertight seals throughout the building.

Do not store swimming pool chemicals in your building. Combustibles and corrosives must be stored in air tight approved containers.

Keep this Owner's Manual and Assembly Instructions for future reference.

ACCESSORIES...

A07

ROOF STRENGTHENING (heavy snow load) KITS

Extra roof beams and gable braces designed for added protection against heavy snow accumulation. Increases the strength of your roof.

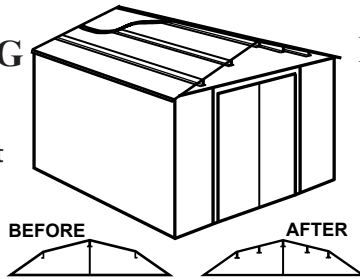

ANCHOR KITS

Model No. AK4

Anchor Kit contains heavy-duty steel augers, 60' (18 m) of steel cable and 4 cable clamps. No digging or concrete pouring, just insert cable under roof, over roof beams, into augers and twist augers into the ground. For buildings larger than 10'x9' (3,0 m x 2,6 m), use 2 kits.

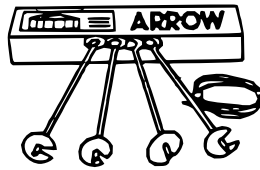

Model No. AK100

New concrete anchor system permits anchoring any size Arrow building directly to a concrete slab. Each kit contains heavy-duty, hot-dipped galvanized steel corner gussets and perimeter clips which fit over the floor frame and lag bolt into a concrete slab. Full assembly instructions and a 1/4" masonry drill bit are included.

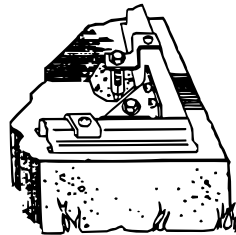

Model No. AK600

Earth Anchor Kit anchors any size Arrow building to the ground. Each kit contains heavy duty, hot-dipped galvanized steel corner gussets and 4 earth anchors.

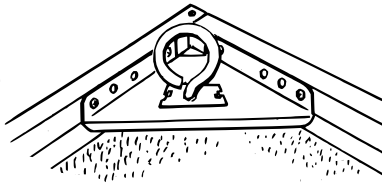

TOOL HANGING RACK

Model No. TH100

The perfect tool organizer. Twin 25 1/2" (64,8 cm) steel channels plus five heavy-duty snap-in hangers and a small tool holder for screwdrivers, pliers, etc. Holders slide along channel for fully adjustable spacing. Great for garage, basement, or the back of any door. Fits all Arrow storage buildings.

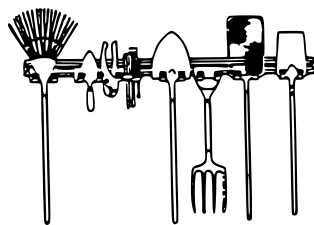

FLOOR FRAME KITS

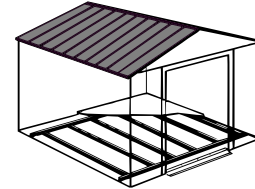

MODELS FB47410, FB5465, FB106-A
FB109-A and FB1014-A

A simple new floor frame system made of heavy-duty, hot-dipped galvanized steel. Use as base for plywood, sand or stone.

ATTIC KIT / WORKBENCH KIT

Model No. AT101

Heavy-duty galvanized steel bars that fit all 10' (3,0 m) wide Arrow buildings. They install quickly and easily to help organize space and create more useable space as an attic or workbench. Will hold up to 250 lbs. (113 kg) evenly distributed.

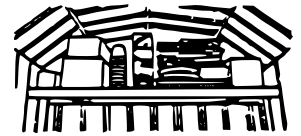

Some drilling required to fit buildings without mid-wall bracing.

SHELF UNITS

Heavy-duty, galvanized steel shelf units help organize storage space. They easily mount on the wall or sit on the floor. Fits all Arrow buildings.*

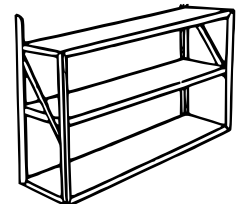
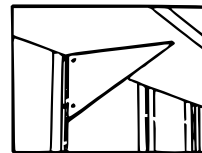
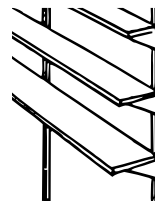

Model No. SS404

- Makes 8" to 12" (20,3-30,5 cm) wide shelves in any length.
- Brackets, braces, hardware included.
- Lumber is not included.

Model No. SS900-B

- Grey color
- 3 shelves
- Holds up to 85 lbs. (38 kg) (even weight distribution)

* Some drilling required to fit buildings without mid-wall bracing.

ORDERING ACCESSORIES....

A08

02/13

We recommend that you purchase accessory items from your local storage building dealer whenever possible; however, because the full line of accessories is not always available from all dealers, Arrow is offering them to you on a direct basis.

There are two ways to order Arrow Storage Building Accessories:

Option 1	Option 2
Accessories can be purchased through arrowsheds.com	Order accessories by telephone using your MasterCard or Visa credit card. Call toll free 1-800-851-1085 (Customer Service). Allow 2 weeks for delivery.

SPECIAL NOTE:

If your accessory is shipped via truck line a day time phone number is required to arrange delivery. If no one is available to sign for the delivery, you may be subject to a re-delivery charge assessed by the carrier.

Base

ABX09

The Base For Your Building

OPTION 1: Wood Platform

If you decide to build your own base, be sure to select the appropriate materials.

These are the recommended materials for your base:

2 x 4's (38 mm x 89 mm) Pressure Treated Lumber

5/8" (15,5 mm) 4 x 8 (1220 mm x 2440 mm) Plywood-exterior grade NOTE: Pressure Treated Lumber must not be used where it will make contact with your storage building. The properties of Pressure Treated Lumber will cause accelerated corrosion.

If Pressure Treated Lumber comes in contact with your storage building your warranty will be voided.

10 & 4 penny Galvanized Nails Concrete Blocks (optional)

The platform should be level and flat (free of bumps, ridges etc.) to provide good support for the building. The necessary materials may be obtained from your local lumber yard.

To construct the base follow instructions and diagram.

Construct frame (using 10 penny galvanized nails)

Measure 16"/24" (40,6 cm/61,0 cm) sections to construct inside frame (see diagram)

Secure plywood to frame (using 4 penny galvanized nails)

Allow 6 - 7 hours for construction.

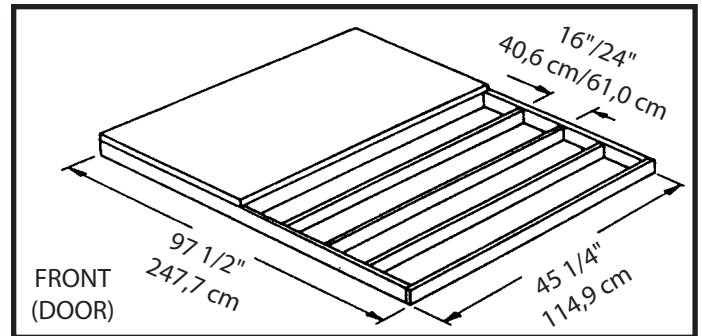

Note: Platform/Slab will extend 9/16" (1,4 cm) beyond floor frame on all four sides. Seal this 9/16" (1,4 cm) of wood with a roofing cement (not included), or bevel this 9/16" (1,4 cm) of concrete when pouring, for good water drainage.

OPTION 2: Concrete Slab

The slab should be at least 4" (10,2 cm) thick. It must be level and flat to provide good support for the frame.

The following are the recommended materials for your base.

1 x 4's (19 mm x 89 mm) (will be removed once the concrete cures)

Concrete Sheet of 6 mil plastic

We recommend for a proper strength concrete to use a mix of:

1 part cement 3 parts pea sized gravel 2 1/2 parts clean sand

Prepare the Site/Construct a Base

1. Dig a square, 6" (15,2 cm) deep into the ground (remove grass).
2. Fill up to 4" (10,2 cm) in the square with gravel and tamp firm.
3. Cover gravel with a sheet of 6 mil plastic.
4. Construct a wood frame using four planks of 1x4 (19 mm x 89 mm) lumber.
5. Pour in concrete to fill in the hole and the frame giving a total of 4" (10,2 cm) thick concrete. Be sure surface is level.

Allow 3 - 5 hours for construction and a week for concrete curing time.

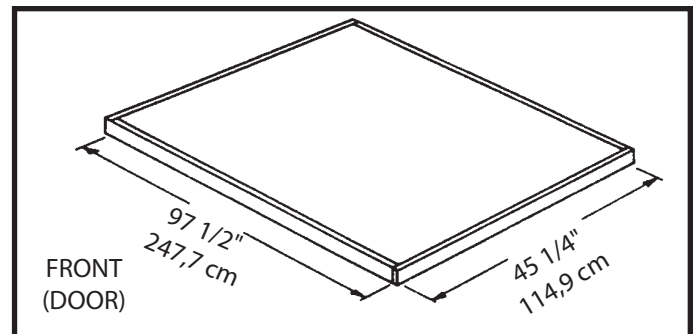

Note: Finished Slab dimensions, with lumber removed.

Anchoring

A10

Anchoring Down The Building

It is important that the entire floor frame be anchored after the building is erected.

Below are recommended ways of anchoring.

Arrow Anchoring Kit: (Model No. AK4 or 60298)

Recommended for use with any suggested base.

Contains: 4 Anchors with Cable, Clamps and installation instruction.

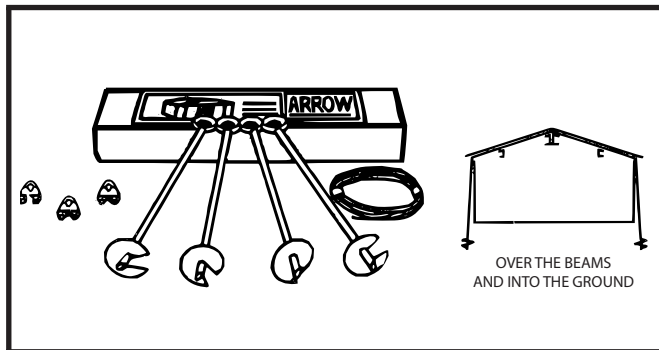

Anchoring into Wood/Post:

Use 1/4" (6 mm) Wood Screws. There are 1/4" (6 mm) dia. holes provided in the frames for proper anchoring.

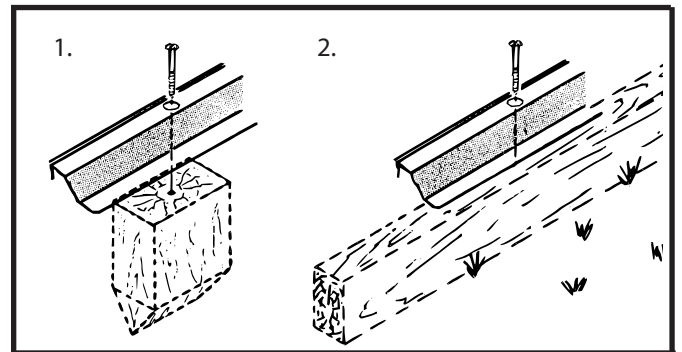

Arrow Anchoring Kit: (Model No. AK100 or 68383)

Recommended for use with the concrete base.

Contains: Corner gussets, perimeter clips, hardware, 1/4" masonry drill bit and installation instruction.

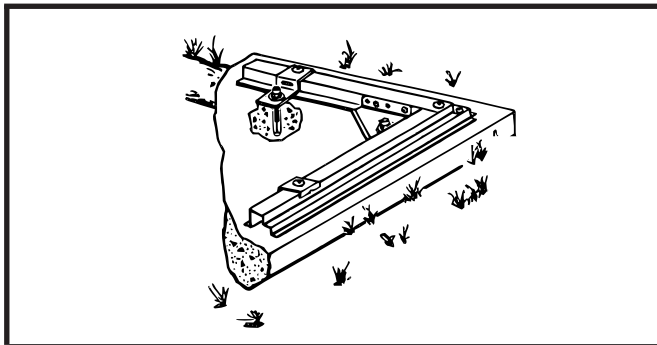

Anchoring into Concrete:

1. For poured concrete slab or footing or patio blocks: Use 1/4" x 2" (6 mm x 51 mm) Lag Screws.
2. For Anchor Post of Concrete poured after building is erected: Use 1/4" x 6" (6 mm x 152 mm) Lag Screws.

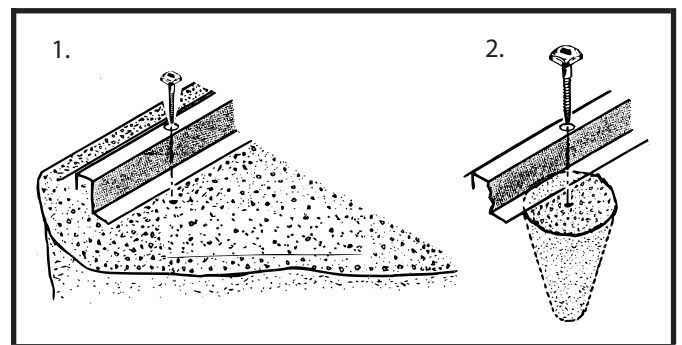

Hardware

ABX11

Remove from bag of screws
and save for the last step



65103
#8-32 Hex Nut (62)



65900A
#10Bx1/2" (13 mm)
Black Screw (8)
(Packed with Screws)



65923
#8-32x3/8" (10 mm)
Bolt (62)



65004
#8Ax5/16" (8 mm)
Screw (234)

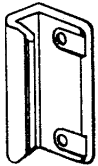

66045
Handle (2)

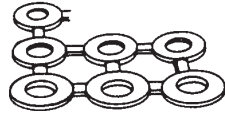

66646
Washer (235)
(6 sheets of 40)



65109
#8-32 Acorn Nut (6)
(Packed with Screws)



66775
Plug (2)
(Packed with Screws)

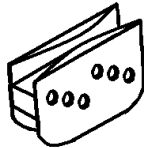

66769
Door Slide (4)

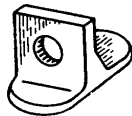

66382
Lower Door Guide (4)

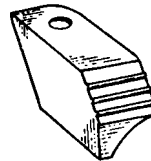

66183
Roof Trim Cap
(2 right & 2 left)

Parts List

ABX12

Assembly Key No.	Part Number	Part Description	Quantity in Carton	Check List
1	10566	Rear Wall Angle	2	
2	6617	Door Track Splice	1	
3	10498	Horizontal Door Brace	4	
4	10573	Front Header	2	
5	10557	Roof Panel	3	
6	10562	Right Gable	1	
7	80015	Left Gable	1	
8	9316	Right Roof Trim	2	
9	10560	Right Roof Panel	1	
10	80013	Left Roof Panel	1	
11	10570	Roof Beam	2	
12	10564	Side Wall Angle	2	
13	10545	Side Wall Channel	2	
14	80017	Left Roof Trim	2	
15	8941	Ramp	1	
16	10544	Side Floor Frame	2	
17	10563	Wall Panel	4	
18	6278	Vertical Door Brace	2	
19	10478	Right and Left Doors	2	
20	6243	Wall Panel	2	
21	9369	Door Jamb	2	
22	9924	Rear Wall Channel	2	
23	9377	Rear Floor Frame	2	
24	9378	Door Track	2	
25	9379	Front Floor Frame	2	
26	9381	Front Corner Panel	2	
27	9385	Rear Corner Panel	2	

Step 1

B14 ctr

Parts Needed For Floor Frame Assemblies

8941 Ramp (1)
9379 Front Floor Frame (2)
9377 Rear Floor Frame (2)

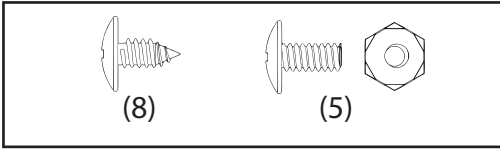

The front floor frame is made up of three pieces. The rear floor frame is made up of two pieces. The holes in these pieces will align when the pieces are positioned with correct amount of overlap. The illustrations below show the proper overall length for the front and rear. Proceed as follows:

1 Place the front floor frames as shown. Center the ramp, with drain holes facing outside, on top of the two front floor frames. Join the frames by inserting eight screws.

2 Overlap the rear floor frames as shown. The holes in these pieces will align when the pieces are positioned with correct amount of overlap. See the illustrations below for the proper overall length of the rear floor frame. Join the frames by inserting five bolts into frame set as shown.

3 Double check the length of each and set these pieces aside for later use.

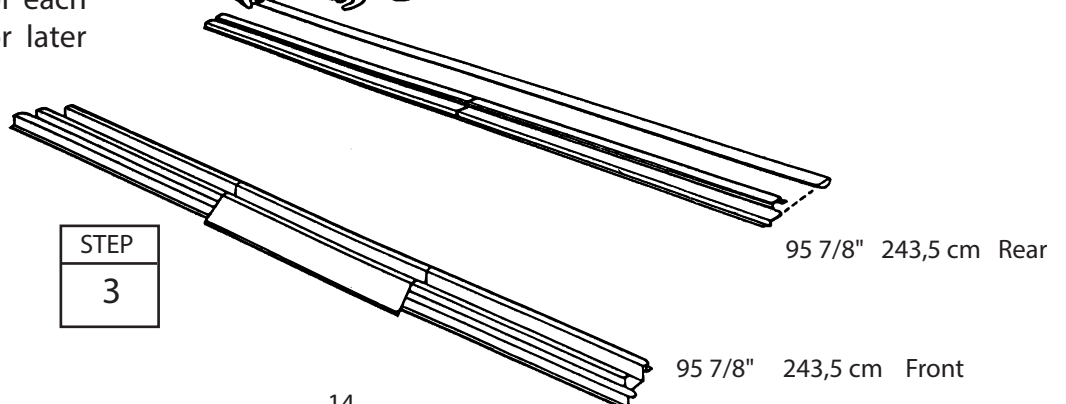
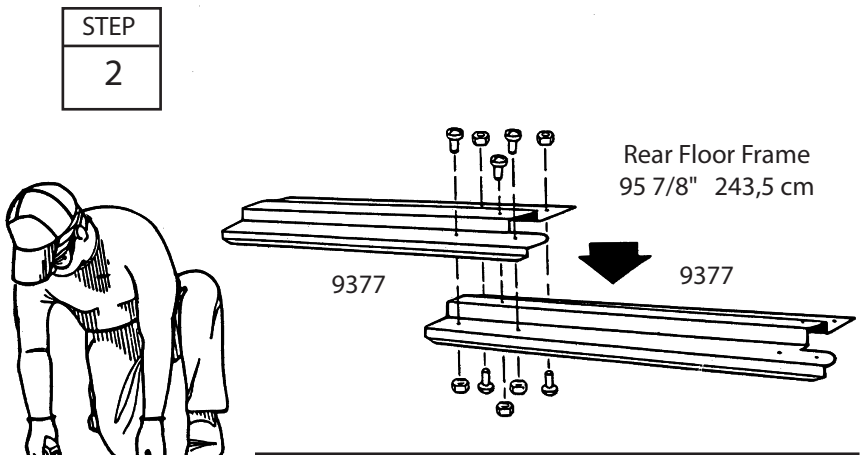
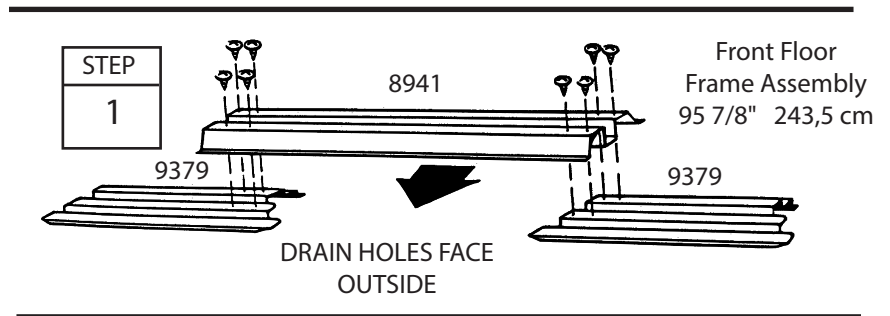
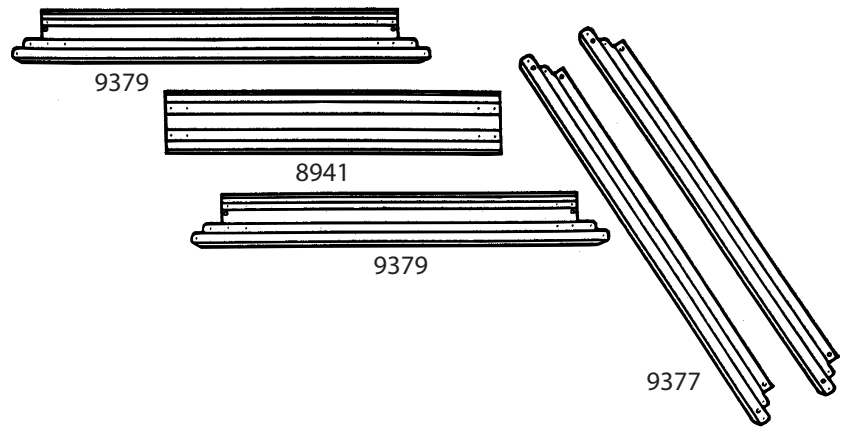

Step 2

ABX15

Parts Needed For Frame Assemblies

10566 Rear Wall Angle (2)
9924 Rear Wall Channel (2)

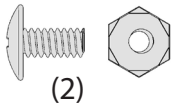

The main frame pieces reinforce the walls. These pieces will later be installed in the center and at the top edge of the rear wall. Proceed as follows:

1 Overlap the rear wall channel pieces as shown in the figure and fasten the two pieces together with one bolt in the center hole (five holes will align).

2 Overlap the rear wall angle pieces as shown in the figure and fasten them together with one bolt in the center hole.

3 Double check the length of each and set these pieces aside for later use.

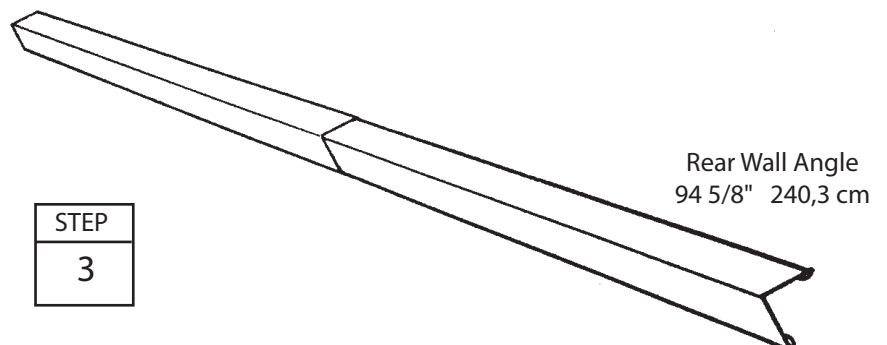
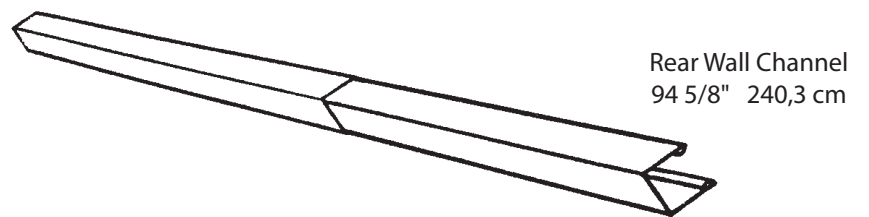
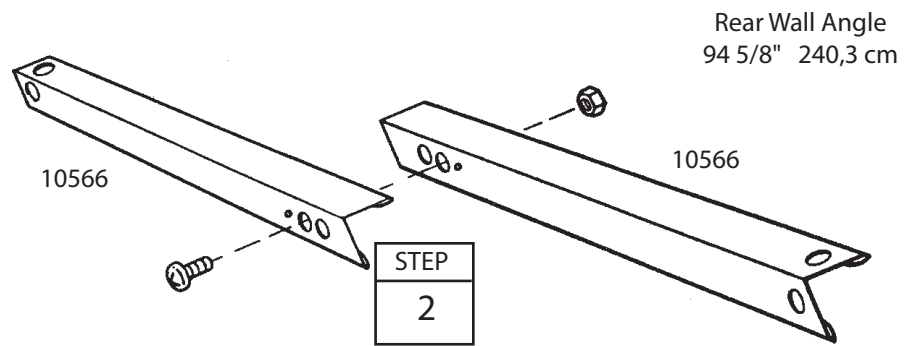
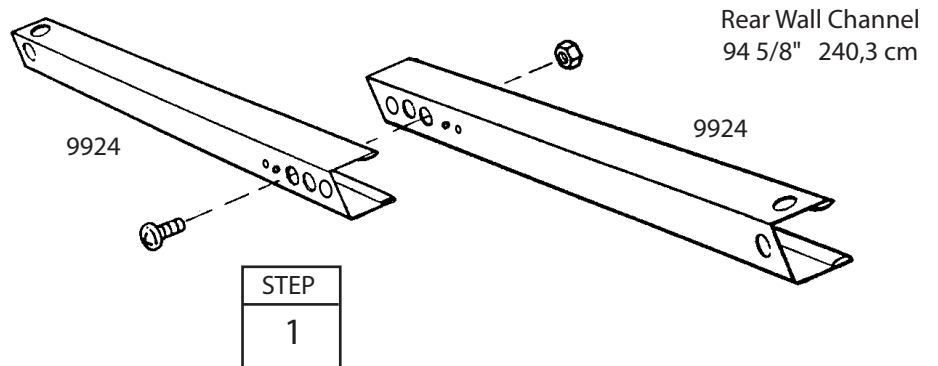

Step 3

ABX16

Parts Needed For Roof Beam Assemblies

10570 Roof Beam (2)

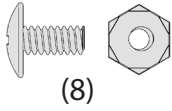

The roof beams support the roof panels. The roof beam is made up of two pieces overlapped at the center.

Hint: These pieces are force-fitted, so you may have to press hard to join them together.

1 Place the end of one roof beam inside a second roof beam so that the six holes in each piece align. Do not insert bolts yet.

2 Fasten the pressed-together roof beam with eight bolts.

3 Double check the length and set this piece aside for later use.

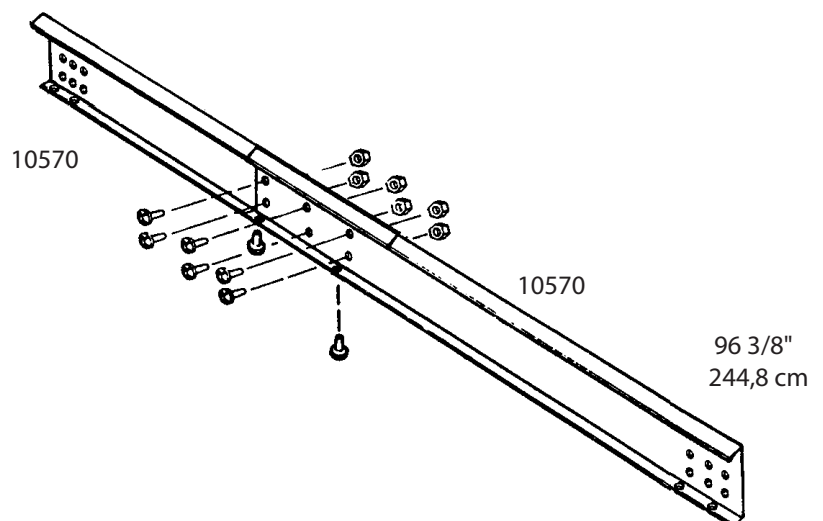
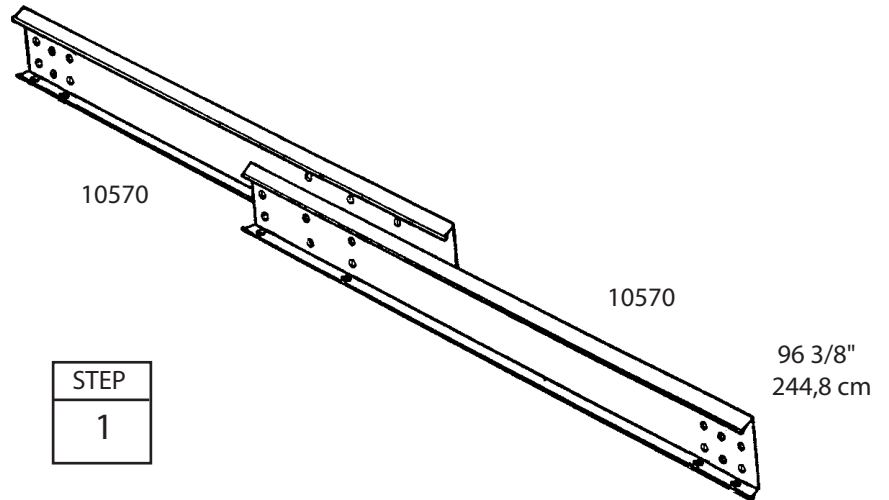

Step 4

ABX17

Parts Needed For Door Track / Header Assembly

6617 Door Track Splice (1)
9378 Door Track (2)
10573 Header (2)

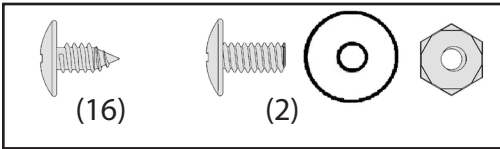

The door track/header assembly supports the sliding doors and reinforces the front wall. It is made up of five pieces.

1 Using the door track splice, (painted), join the door track (galvanized) pieces end-to-end as shown.

2 Insert four screws from the under-side only.

3 Using this door track assembly, with small holes on top, join the header pieces, short leg on top, as shown using screws.

4 Fasten overlap area of header with 2 bolts and nuts.

5 Position door slides onto the legs, from the end of door track assembly, as shown in the end view.

6 Set this piece aside for later use.

NOTE:
Door Track Splice (painted part)

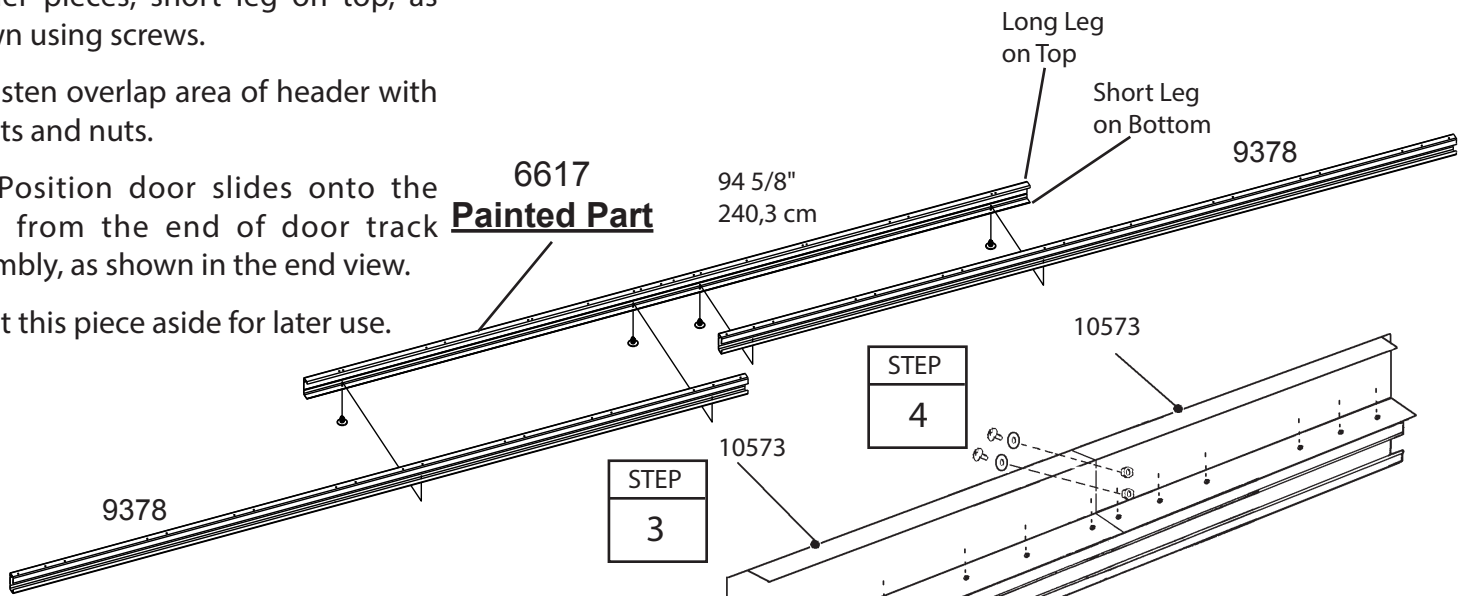
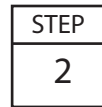
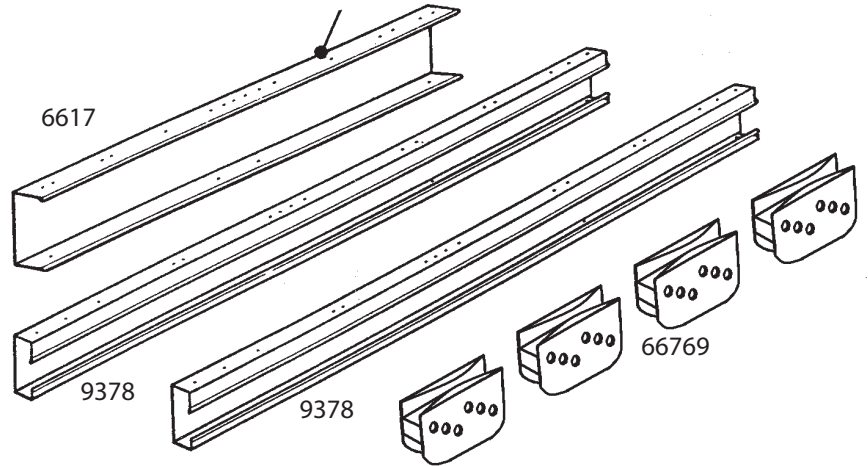

END VIEW

CORRECT

INCORRECT

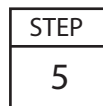
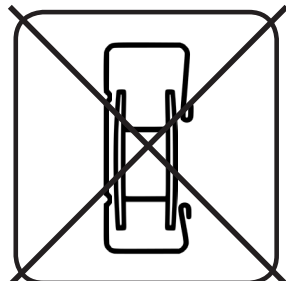
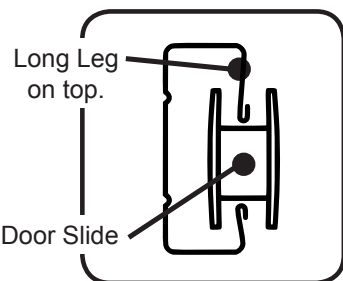

Step 5

ABX18

Parts Needed For Floor Frame

Front Floor Assembly (1)
10544 Side Floor Frame (2)
Rear Floor Assembly (1)



(8)



(2)



1 Assemble the four corners of the floor frame using two screws at each corner as shown. At the front corners fasten bolts through from the bottom with nuts on top.

2 Measure the floor frame diagonally. When the diagonal measurements are equal, the floor frame is square.

STEP
1

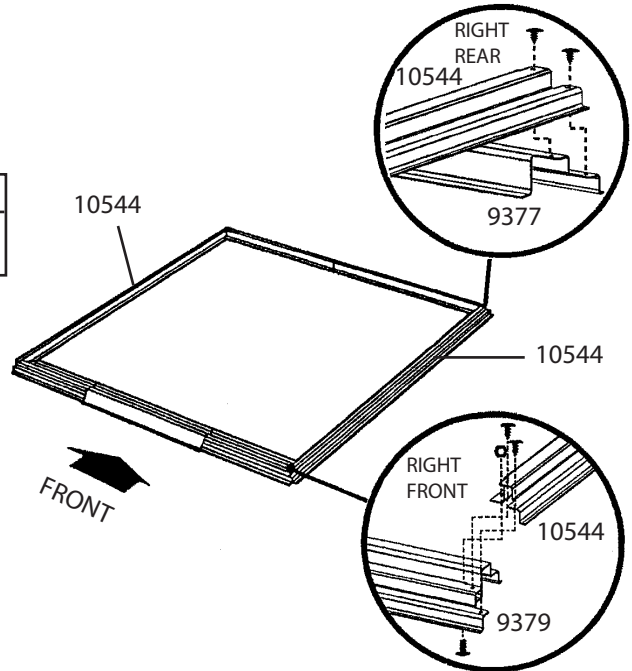

NOTE

If using a wood platform or concrete slab do not fasten the floor frames to your base at this time. You will anchor the building after it is erected.

When Diagonal Measurements are Equal the Floor Frame is Square.

STEP
2

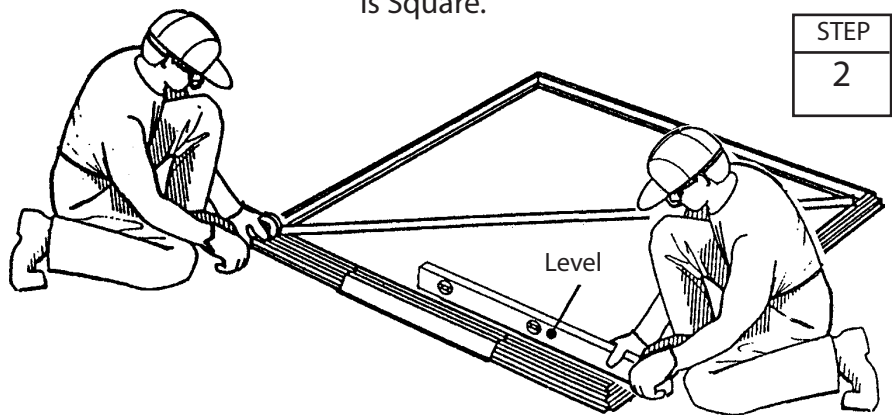

The floor frame must be square and level or holes will not align.

Step 6

ABX19

Parts Needed For Corners

9381 Front Corner Panel (2)
9385 Rear Corner Panel (2)

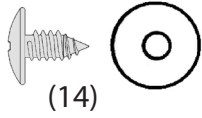

NOTE

The remainder of the building assembly requires many hours and more than one person. Do not continue beyond this point if you do not have enough time to complete the assembly today. A partially assembled building can be severely damaged by light winds.

Each screw and bolt in the wall requires a washer.



CORRECT



INCORRECT

1 Position rear corner panels at the rear corners, as shown. The widest part of each corner panel must be placed along the rear of the building. Fasten the corner panels to the floor frame with four screws.

2 Position front corner panels at the corners of the floor frame as shown. The widest part of each corner panel must be placed along the front of the building. A small gap will exist between front corner panel and ramp. Fasten the corner panels to the floor frame with three screws.

NOTE

Be careful to install the correct panel in each position as shown

3 Double-check the part numbers of the wall panels, before proceeding.

The floor frame must be square and level or holes will not align.

STEP
1

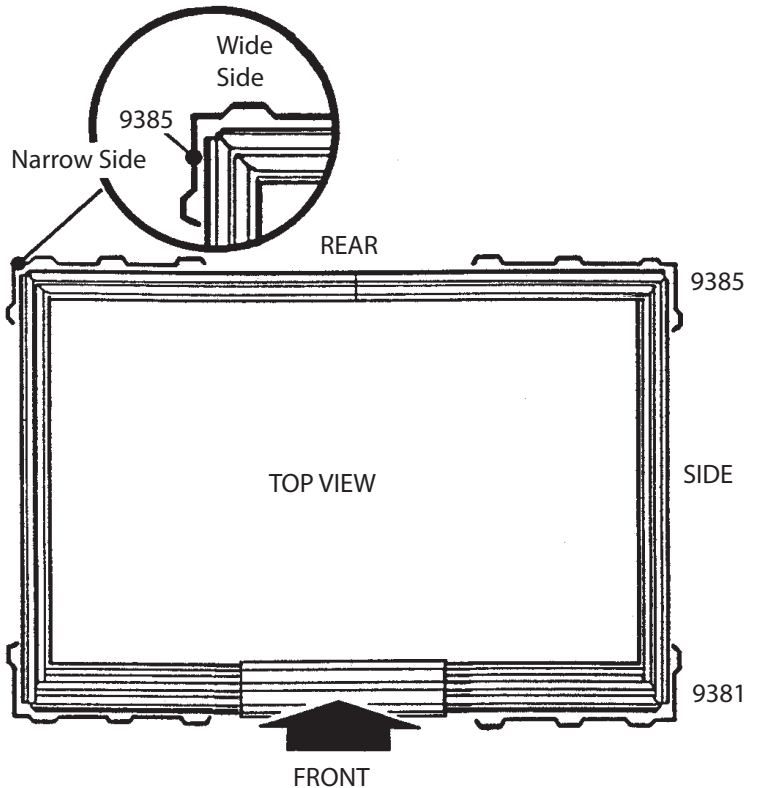

STEP
2

STEP
3

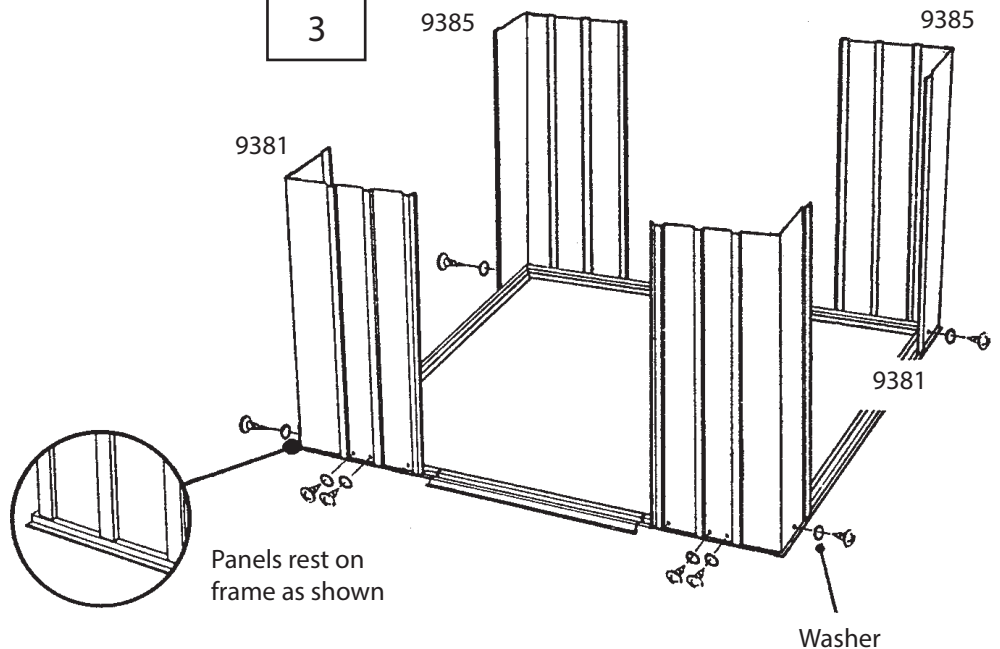

Step 7

ABX20

Parts Needed For Frames

Rear Wall Angle Assembly (1)
Rear Wall Channel Assembly (1)
10545 Side Wall Channel (2)
10564 Side Wall Angle (2)
Door Track/Header Assembly (1)

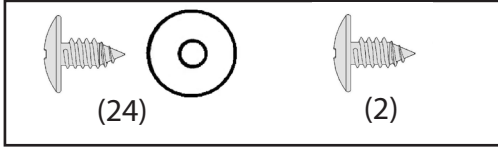

The main frame pieces give rigidity to the side walls and provide a surface for attaching the gables which support the roof.

1 Fasten the rear wall angle across the inside top of the rear wall using screws.

2 Fasten the rear wall channel across the middle of the rear wall using screws.

NOTE
The upper leg of the side wall angles must face the outside of the building.

3 Fasten the side wall angles across the inside top of the side panels using screws.

4 Fasten the side wall channels across the middle of the side panels using screws. Fasten overlaps in rear corners with screws.

5 Fasten the door track/header assembly across the top of the front wall panels using screws. See the figure.

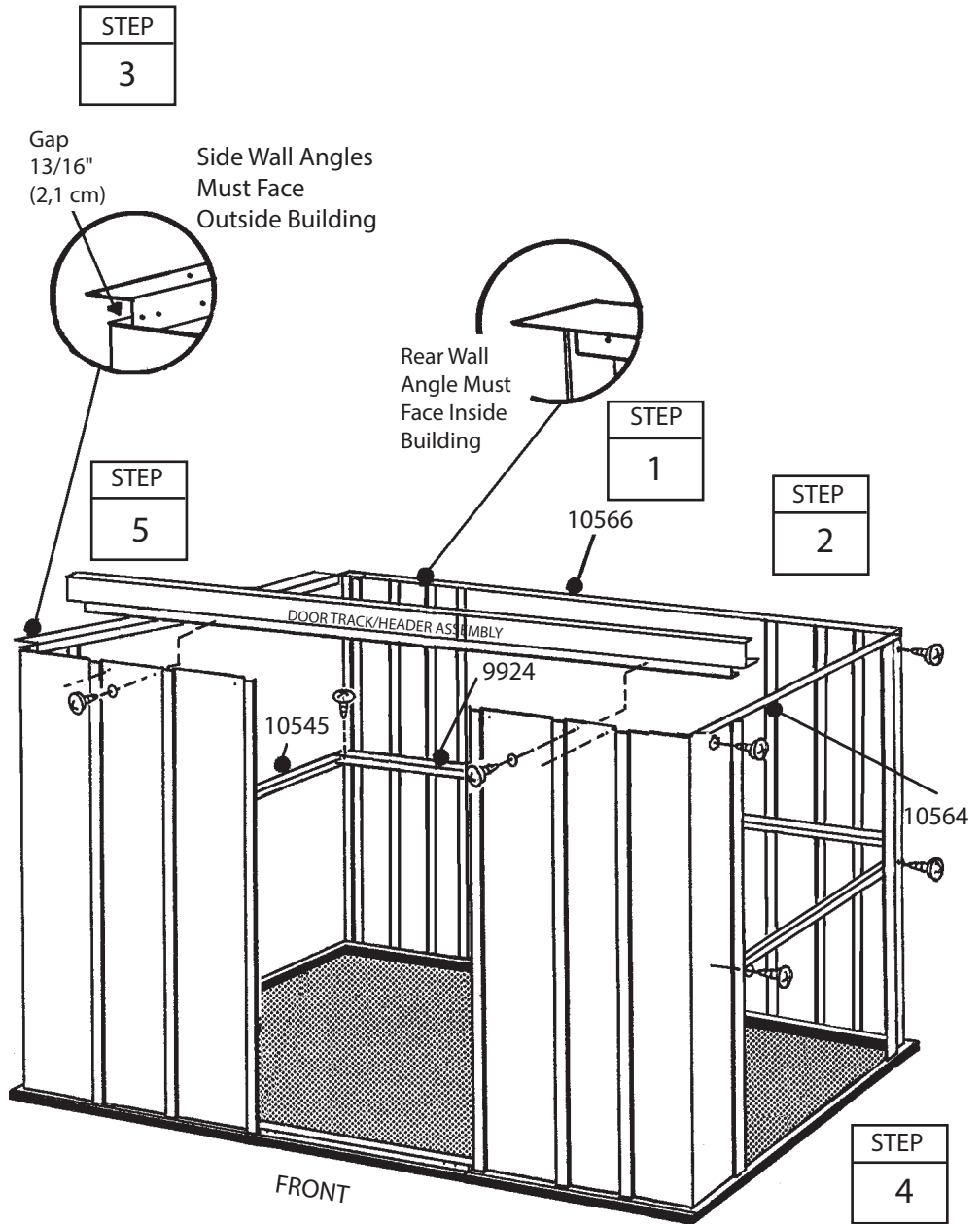

Step 8

ABX21

Parts Needed For Wall Panels

6243 Wall Panel (2)
10563 Wall Panel (4)

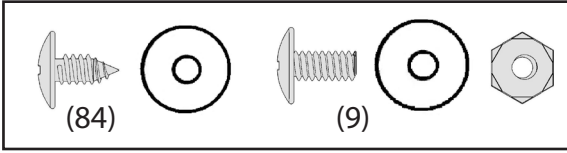

The wall panels come in two widths. Each wall panel has a crimped rib on one side. The crimped rib should go under the rib of the panel that follows it.

1 Locate all of the wall panels and set each one alongside the building.

2 Be sure that you have the correct panels in each position. Do this by overlapping the panels and determining if the holes line up with the holes in the frame.

3 Fasten the wall panels at the top and bottom with screws.

4 Fasten the center of each panel to the wall channel with screws. Fasten overlapping ribs as before.

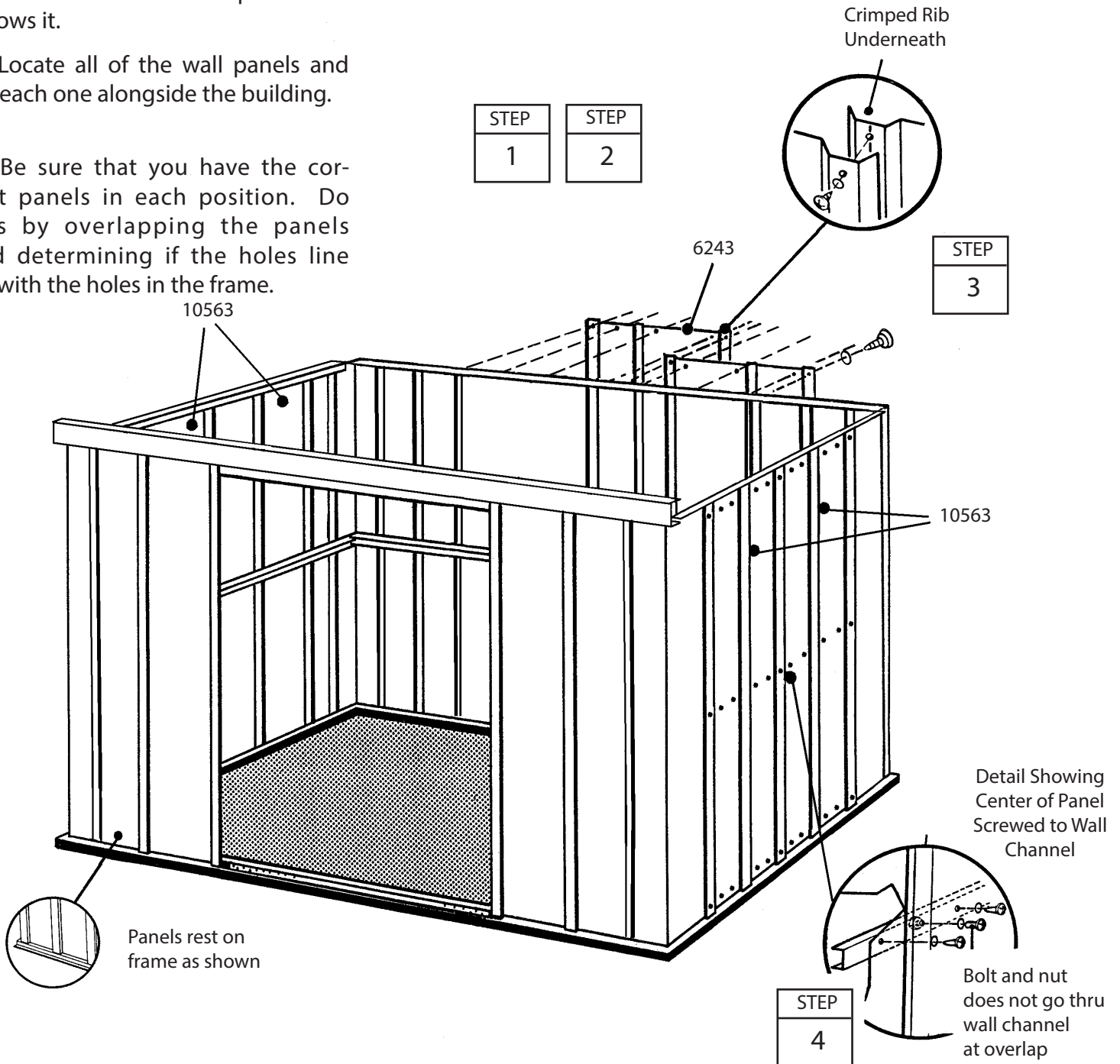

Step 9

ABX22

Parts Needed For Door Jamb

9369 Door Jamb (2)

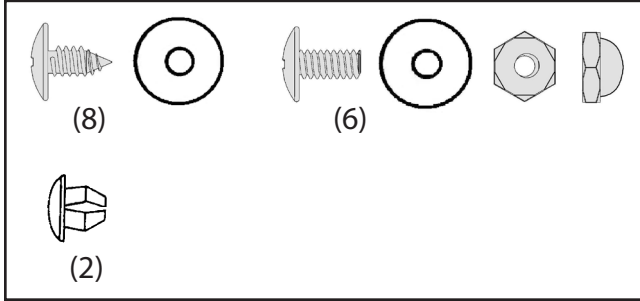

The door jambs reinforce the door opening and provide an attractive trim. Follow these steps for both door jambs.

1 Fasten a door jamb to the front panel with three bolts, nuts and acorn nuts, as shown. Push a plug into hole at center of jamb, closest to door opening.

2 Fasten the top of the door jamb to the door track with two screws. Do the same for the bottom into frame.

Repeat steps 1 and 2 for the opposite door jamb.

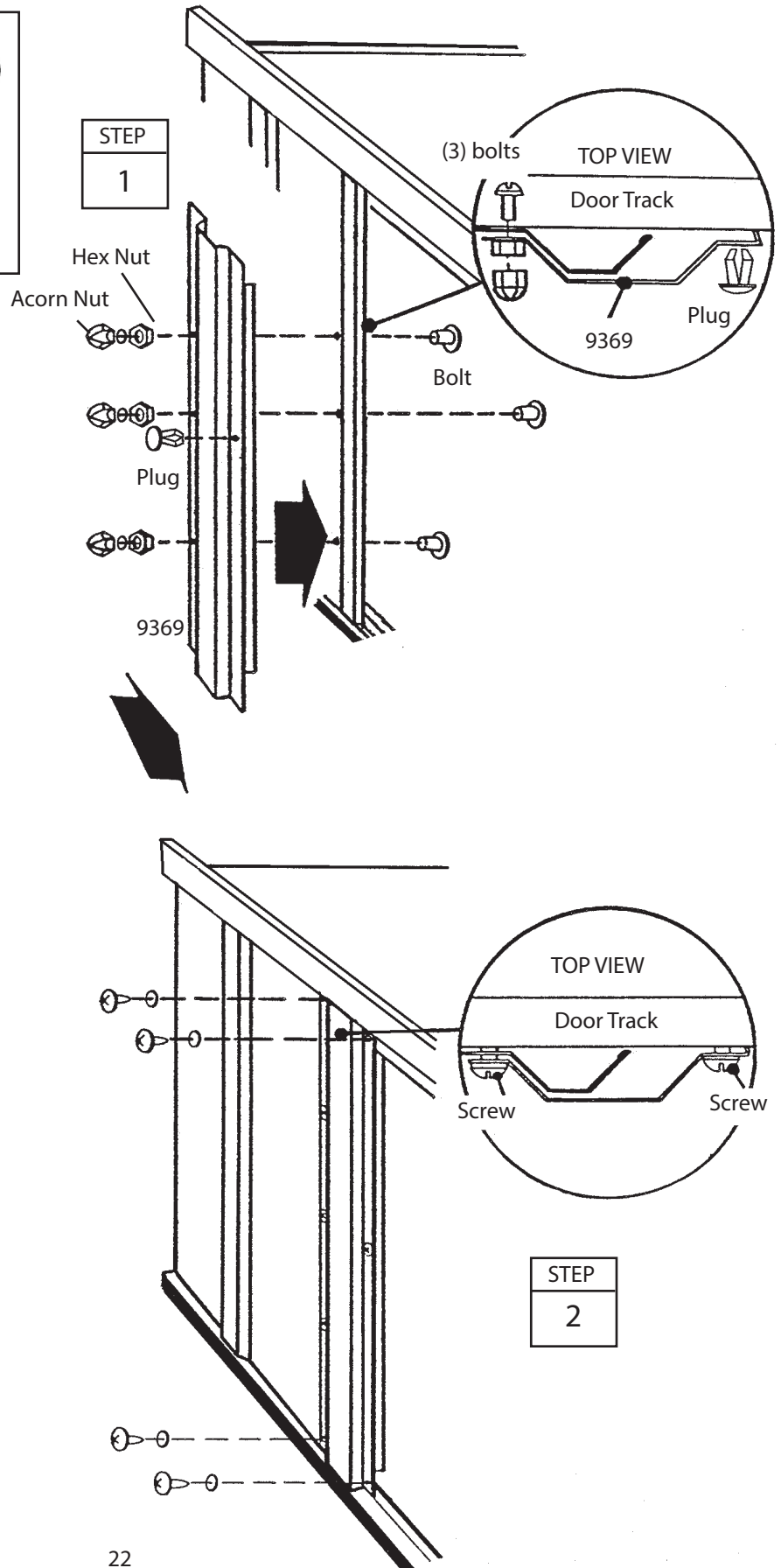

Step 10

ABX23

Parts Needed For Roof Beam

Roof Beam Assembly (1)

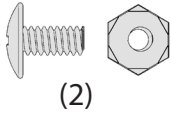

1 The dimension stated below measures from the end of the angle towards the front of the building. Fasten the roof beam assembly, small holes on top, to the side wall angle with a bolt and nut.

STEP
1

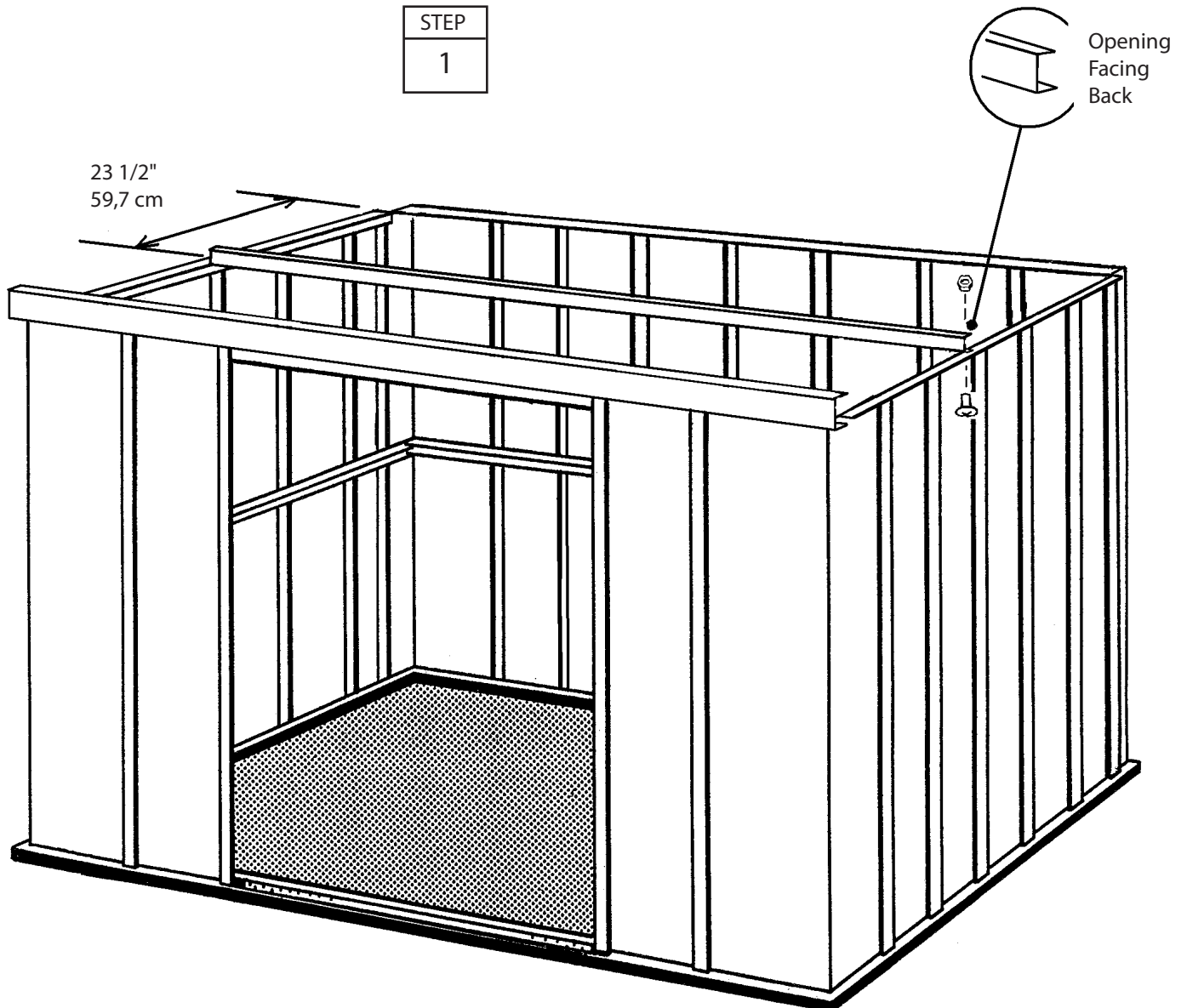

Step 11

ABX24

Parts Needed For Right/Left Roof Panels

10560 Right Roof Panel (1)
80013 Left Roof Panel (1)

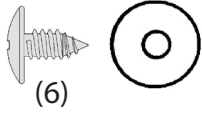

2 Position a right roof panel at the right side and fasten to the header, roof beam and rear wall angle using screws as shown.

Installing the roof panels is best done with a step ladder. Begin installing roof panels at the right side of the building. Each screw and bolt in the roof requires a washer.

3 Install the left roof panel 80013 on the left side in the position shown below.

NOTE

Measure the building diagonally again and make adjustments to make sure the building is square and level. This will make the roof panels fit better, and holes will align.

1 Locate the roof panels and find the right roof panel part number 10560.

STEP
3

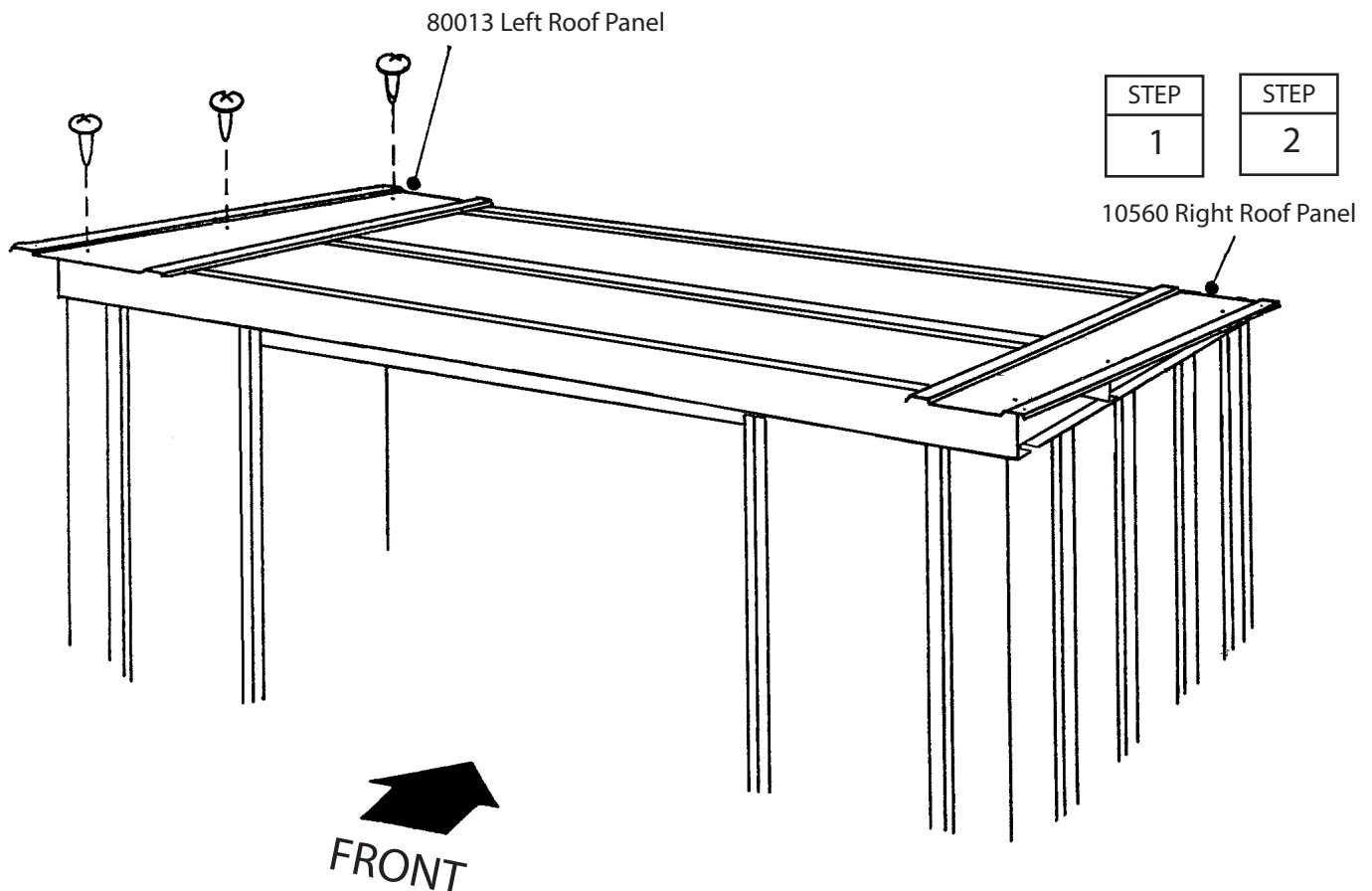

Step 12

ABX25

Parts Needed For Roof Panel

10557 Roof Panel (3)

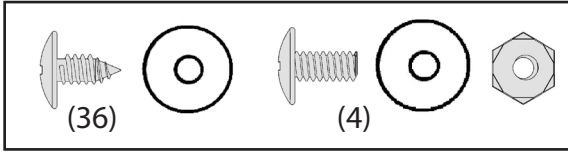

1 Install the roof panels 10557, in the positions shown. Fasten middle of rib overlap with a bolt and nut.

NOTE

Narrow roof panel crimped rib is overlapped by wide rib of adjacent panel where possible.

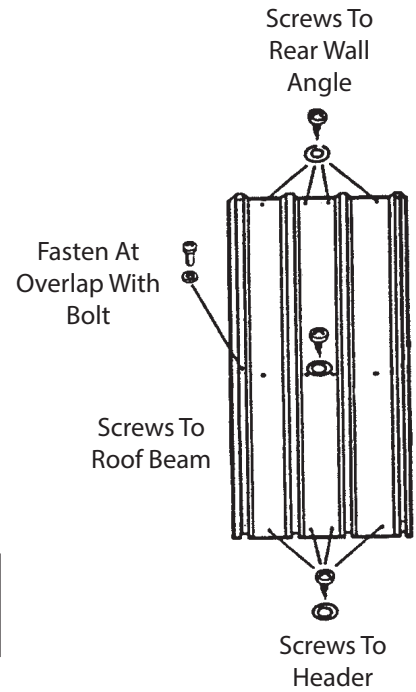

STEP
1

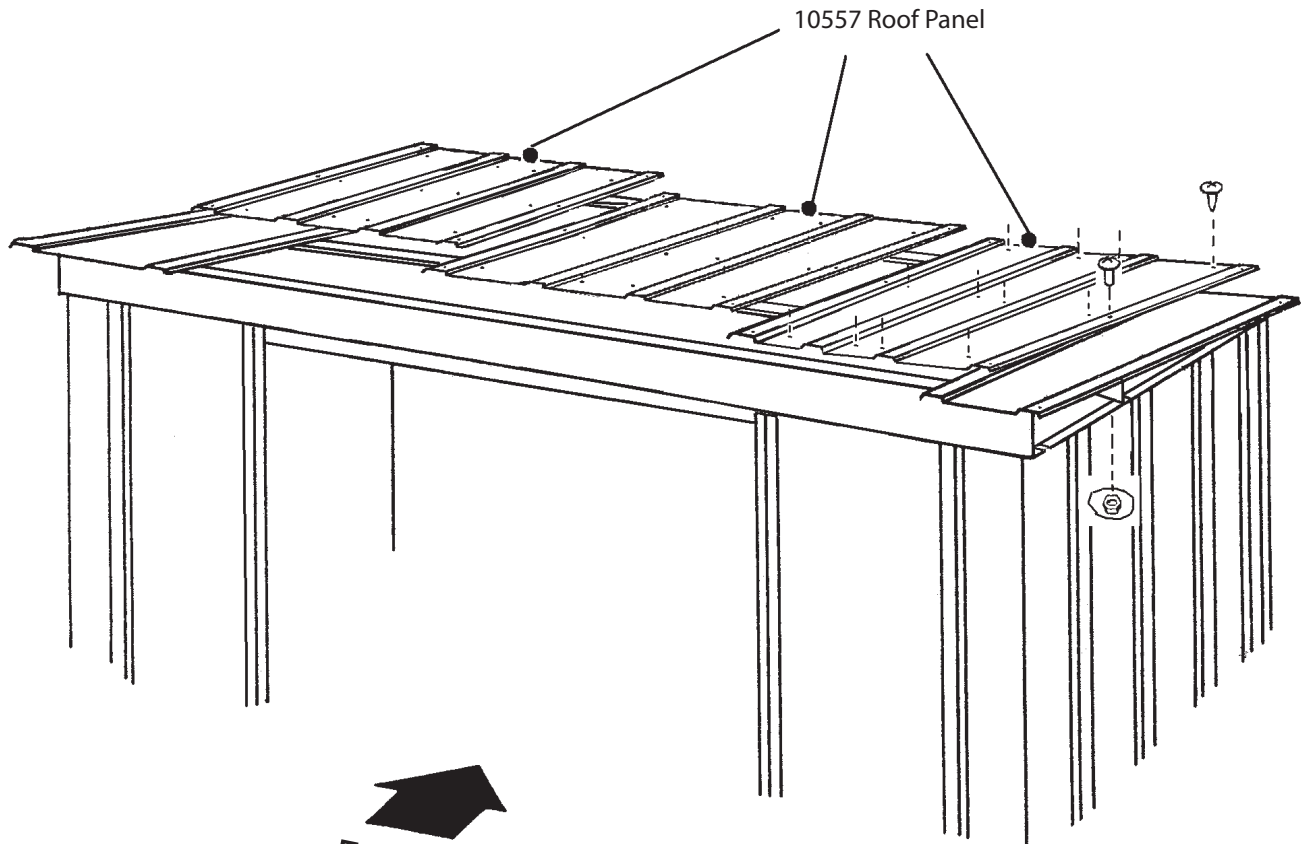

FRONT

Step 13

ABX26

Parts Needed For Gables

10562 Right Gable (1)
80015 Left Gable (1)

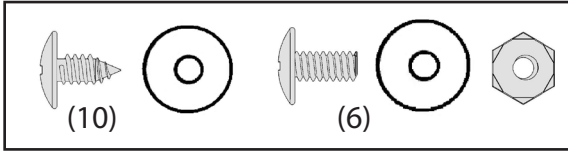

1 Position the right gable at the right end of the completed roof by tucking top edge inside the rib of the right roof panel and sliding the lower leg in between the leg of the side wall angle and top edge of the wall panels.

2 Fasten to the right roof panel, side wall angle and front header using screws, bolts and nuts as shown.

3 Repeat steps 1 and 2 for the left gable.

NOTE
The front leg of the gable must be positioned inside of the front header.

STEP
1

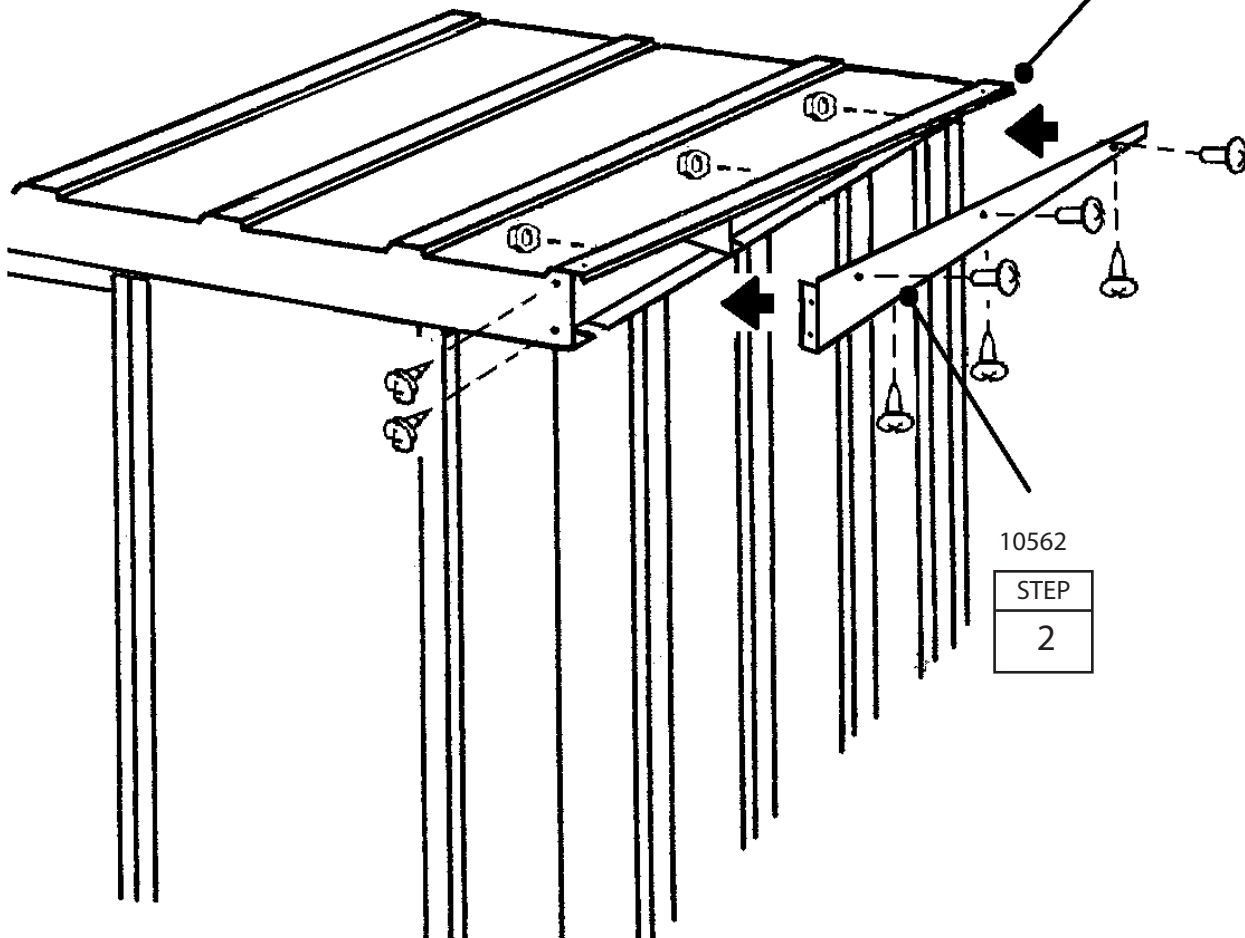
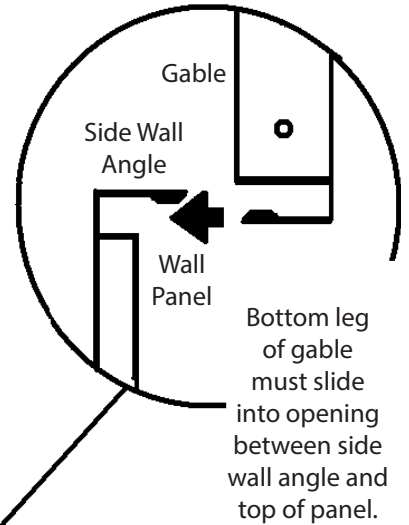

Step 14

ABX27

Parts Needed For Roof Trim

9316 Right Roof Trim (2)
80017 Left Roof Trim (2)

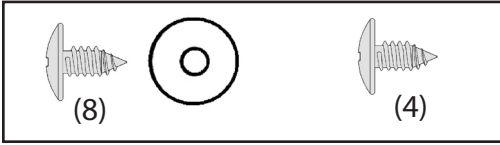

1 Attach the right and left roof trim to the ends of the roof panels on the front and rear of the building using screws at each roof panel overlap.

2 Using your thumb and index finger, overbend the bottom flange of the roof trim at the corner inward enough so the right and left roof trim caps fit onto right and left corners.

3 Fasten the roof trim caps to the roof trim using a screw.

NOTE

A single screw fastens both trim pieces at the overlap.

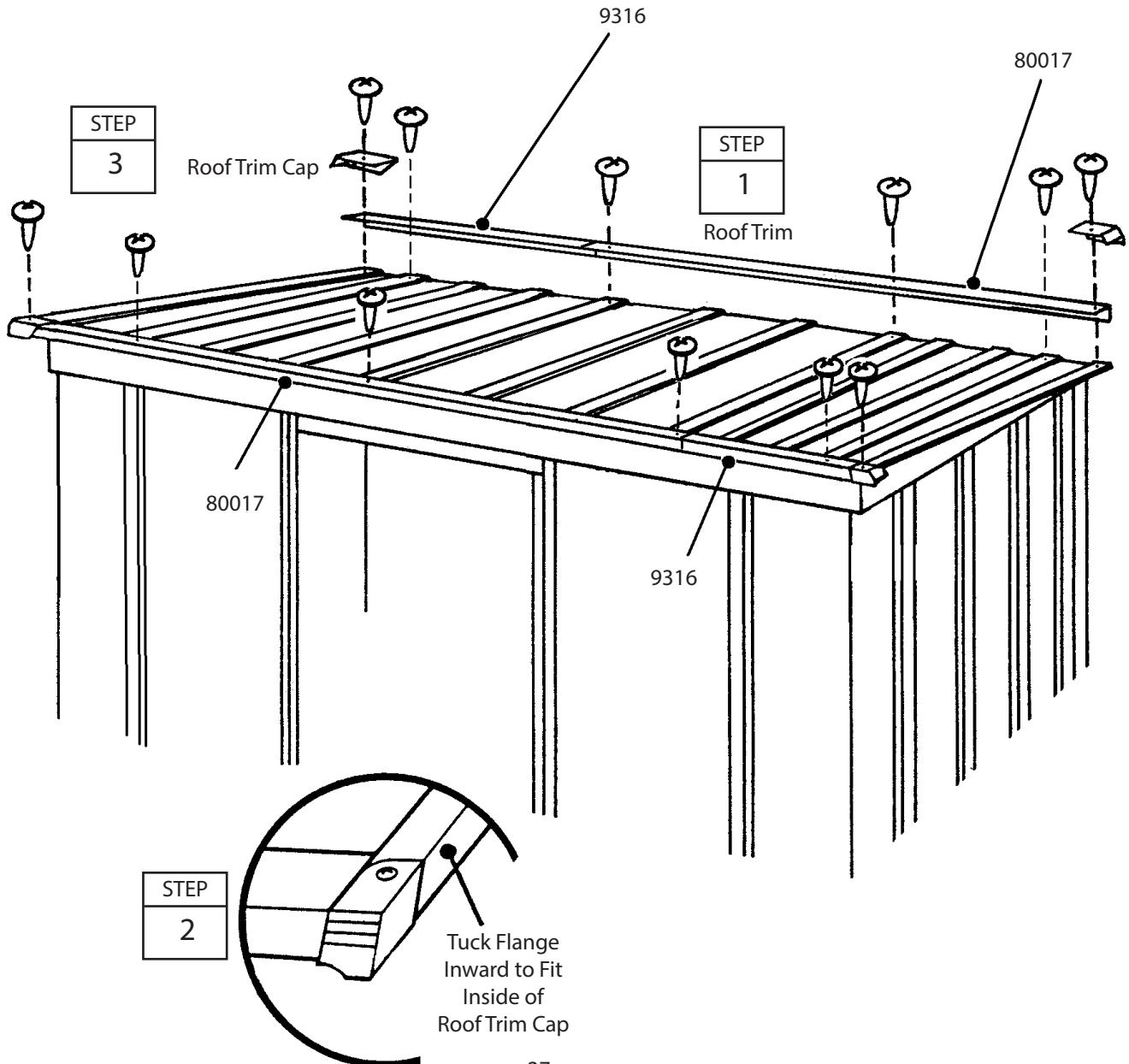

Step 15

ABX28

Parts Needed For Door Assembly

10478 Right and Left Doors (2)
 10498 Horizontal Door Brace (4)
 6278 Vertical Door Brace (2)

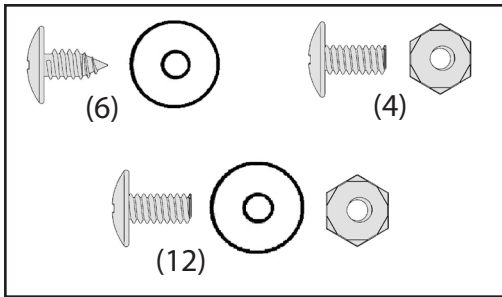

The steps on this page tell how to assemble the right door. You will perform exactly the same procedures for the left door. Each bolt and screw in the door requires a washer. Proceed as follows:

1 Attach the handle to the door with 2 bolts and nuts as shown.

2 Hold the vertical door brace against the center of the inside surface of the door and turn the screw to hold the vertical door brace in place. Fasten to door above and below center connection using 2 screws.

3 Put a horizontal door brace onto the top edge and bottom edge and fasten with 1 bolt in the center.

4 Attach the lower door guides and bolts as shown.

5 Repeat steps 1 through 4 for the left door.

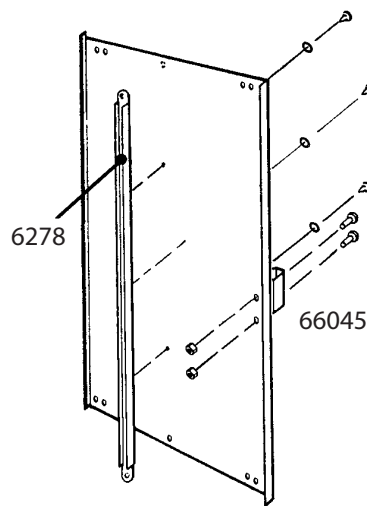
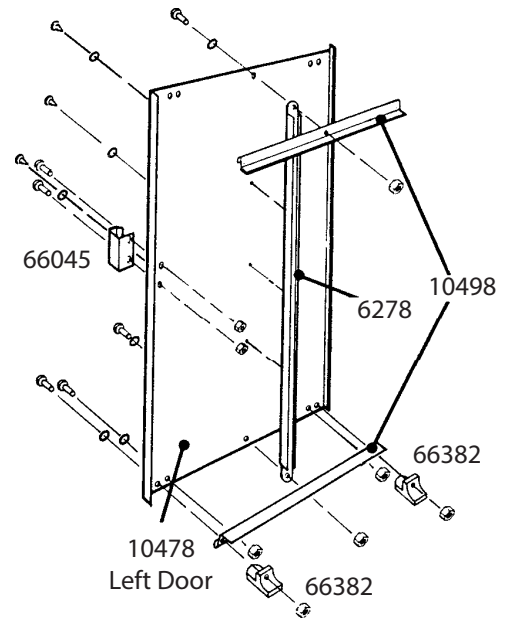
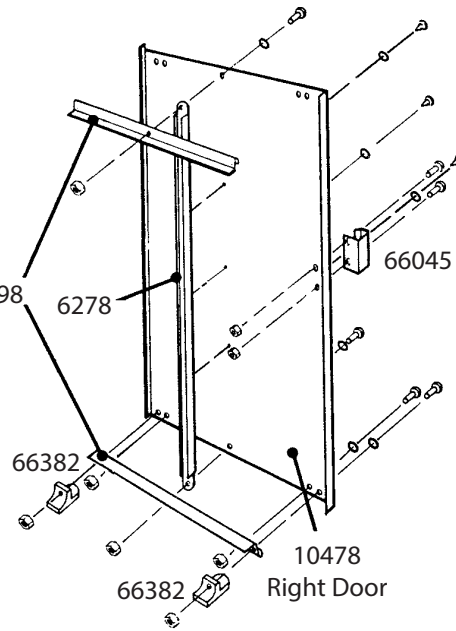

STEP
1

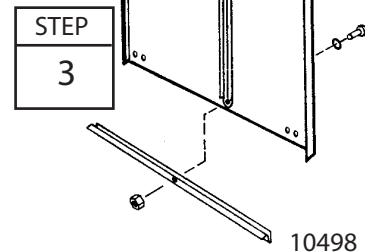

STEP
3

STEP
2

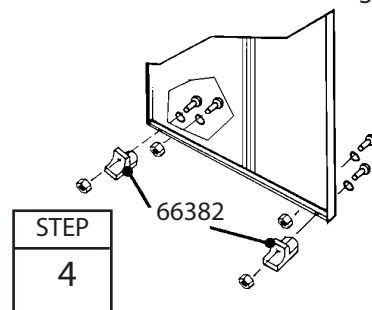

STEP
4

END VIEW
SHOWING:

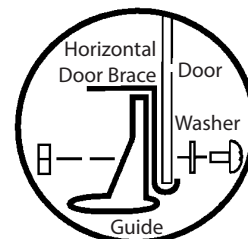

Step 16

ABX29

Parts Needed For Door Installation & Adjustment

Right Door Assembly (1)
Left Door Assembly (1)

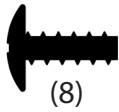

(8)

1 From inside the building, put the bottom of the right door assembly (on your left when you are inside the building) behind door jamb into the front frame track.

2 Position the top of the door so that the holes in the door line up with the holes in the door slides.

3 Fasten the door to the door slides using two #10Bx1/2" (13 mm) screws per door slide.

NOTE

The holes in the door slides allow you to adjust the doors. Place the door in the middle holes.

4 Repeat steps 1 through 3 for the left door.

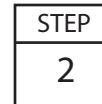
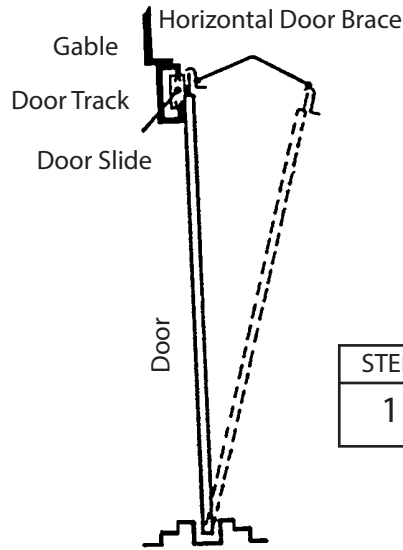

Front Floor Frame Assembly

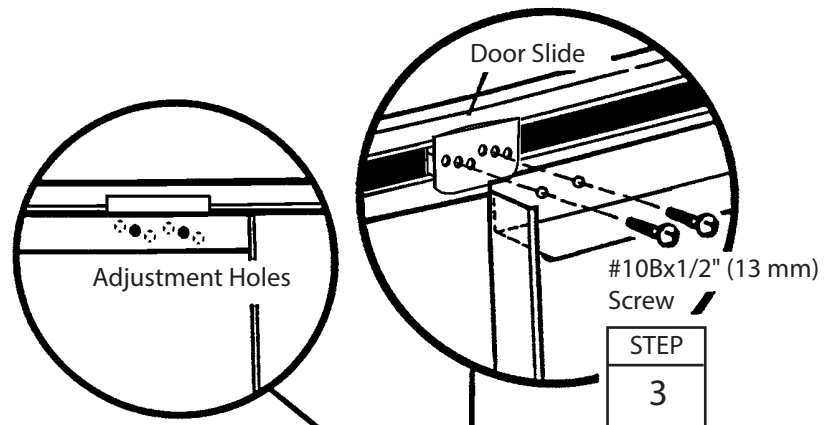

Adjustment Holes Allow Doors to Meet Evenly Along Their Length

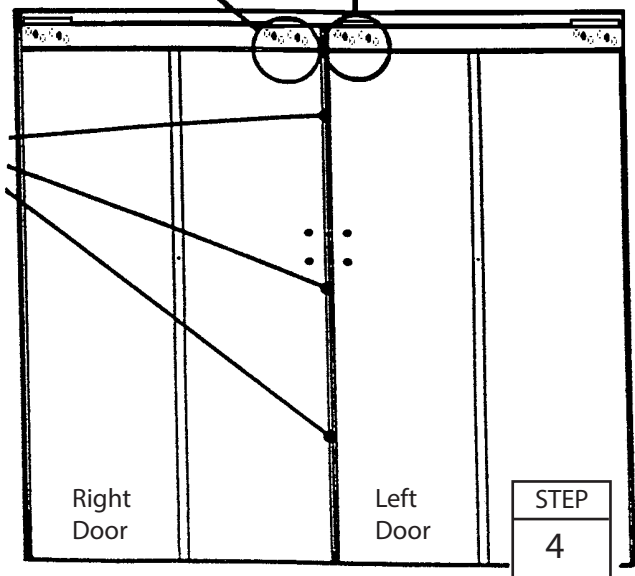

Keep this Owner's Manual and Assembly Instructions for future reference.

Anchoring

Anchor your building at this time.

SOME FACTS ABOUT RUST

Rusting is a natural oxidizing process that occurs when bare metal is exposed to moisture. Problem areas include screw holes, unfinished edges, or where scrapes and nicks occur in the protective coating through normal assembly, handling and use. Identifying these natural rusting problem areas and taking some simple rust protection precautions can help to stop rust from developing, or stop it quickly as soon as it appears.

1. Avoid nicking or scraping the coating surface, inside and out.
2. Use all the washers supplied. In addition to protecting against weather infiltration, the washers protect the metal from being scraped by the screws.
3. Keep roof, base perimeter and door tracks free of debris and leaves which may accumulate and retain moisture. These can do double damage since they give off acid as they decay.
4. Touch up scrapes or nicks and any area of visible rust as soon as possible. Make sure the surface is free of moisture, oils, dirt or grime and then apply an even film of high quality touch-up paint.