

722591217

Owner's Manual & Assembly Guide



www.spacemakersheds.com

Model No. EVRS63 EVRS63EU

VERSA-SHED™

6' x 3'

Nominal Size

! caution
sharp edges *

Gloves must be worn at all times to reduce risk of injury!

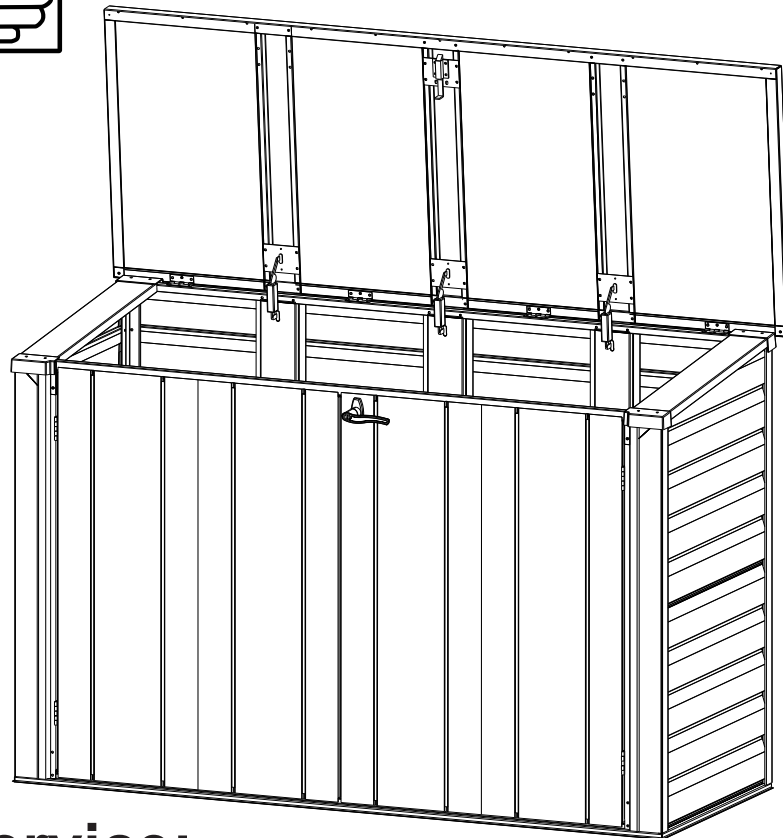

Customer Service:
1-800-851-1085 or
assist@arrowsheds.com

Base Size	70.38" x 28.25" 178,8 cm x 71,8 cm
------------------	---------------------------------------

For proper base construction see page 10

BUILDING DIMENSIONS † Size rounded off to the nearest foot

Approx. † Size	Storage Area		Exterior Dimensions (Roof Edge to Roof Edge)			Interior Dimensions (Wall to Wall)			Door Opening	
			Width	Depth	Height	Width	Depth	Height	Width	Height
6' x 3'	12 Sq. Ft.	47 Cu. Ft.	72"	29 5/8"	50 1/4"	67 5/8"	25 1/2"	48 1/4"	57 1/2"	42.5"
1,8 m x 0,9 m	1,1 m ²	1,3 m ³	182,9 cm	75,2 cm	127,6 cm	171,8 cm	64,8 cm	122,6 cm	146,1 cm	108,0 cm

* See Inside for Detailed Safety Information.

- GB:** Assembly manual in additional languages available online.
Scan QR code below to access.
- FR:** Manuel de montage disponible en ligne dans d'autres langues.
Pour y accéder, scannez le code QR ci-dessous.
- SP:** Manual de montaje en idiomas adicionales disponible online.
Escanee el código QR a continuación para acceder.
- DE:** Montageanleitung in zusätzlichen Sprachen online verfügbar.
Scannen Sie den QR-Code unten, um darauf zuzugreifen.
- IT:** Manuale dell'assemblea in altre lingue disponibile online.
Per accedere effettua la scansione del codice QR in basso.
- PT:** Manual de montagem disponível em outros idiomas online.
Digitalize o código QR abaixo para obter acesso.
- DT:** Samlingshåndbog i yderligere sprog til rådighed online.
Scan QR kode nedenunder for at få adgang.
- SK:** Na internete je k dispozícii návod na zostavenie v ďalších jazykoch.
Dostanete sa k nemu naskenovaním kódu QR.
- CZ:** Návod k montáži v dalších jazycích je k dispozici v online verzi.
Přístup získáte po naskenování QR kódu níže.
- HU:** Az összeszerelési útmutató további nyelveken is elérhető online.
A hozzáféréshez olvassa be az alábbi QR-kódot.
- GR:** Υπάρχει διαθέσιμο στο διαδίκτυο το εγχειρίδιο συναρμολόγησης
σε περισσότερες γλώσσες. Σαρώστε τον παρακάτω κώδικα
QR για να αποκτήσετε πρόσβαση.



SAFETY PRECAUTIONS...

Safety precautions MUST be followed at all times throughout the construction of your building!

sharp edges

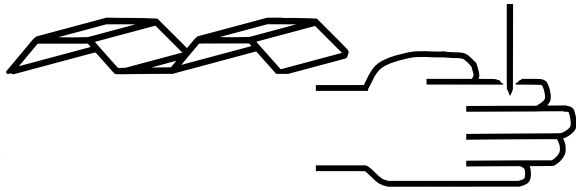

Care must be taken when handling various pieces of your building since many contain sharp edges. Please wear work gloves, eye protection and long sleeves when assembling or performing any maintenance on your building.

no children or pets at worksite



Keep children and pets away from the worksite during construction and until the building is completely assembled. This will help avoid distractions and any accidents which may occur.

always practice proper tool safety

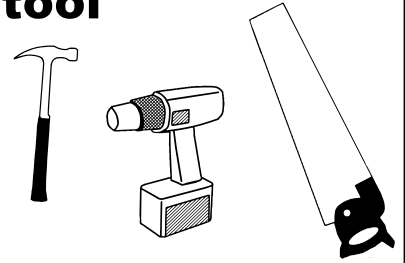

Practice caution with the tools being used in the assembly of this building. Be especially familiar with the operation of all power tools.

beware of wind



Do NOT attempt to assemble your building on a windy day. The large panels can catch the wind like a "sail", causing them to be whipped around making construction difficult and unsafe.

Do NOT attempt to assemble your building before double checking that you have all the parts indicated in the parts lists, as well as all hardware (See pages 6 and 7).

Any building left partially assembled may be seriously damaged by even light winds.

IMPORTANT NOTE ON ANCHORING

- Your building MUST be anchored to prevent wind damage. An anchoring kit is not supplied with your building and you have many options when it comes to anchoring. See anchoring page for more info.
- If you need to take a break from assembly, place sandbags or other weights on the floor frame to temporarily anchor it.

ASSEMBLY TIPS & TOOLS

Watch the Weather Closely: Be sure the day you choose to install your building is dry and calm. Do **NOT** attempt to assemble your building on a windy day. Be careful on wet or muddy ground.

Use Teamwork: Two or more people are required to assemble your building. One person can hold the parts or panels in place while the other person fastens them together and handles the tools. This makes the process of assembling your building faster and safer.

Tools and Materials: Here is a list of some basic tools and materials you will need to assemble your building. Decide which method of anchoring and the type of base you will use to make a complete list of the materials you will need.

WHAT YOU NEED

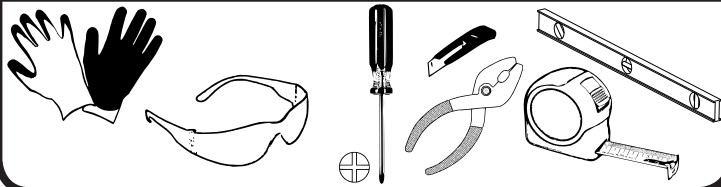

- Work Gloves
- Safety Glasses
- No. 2 Phillips Screwdriver (Magnetic Tip Preferred)
- Utility Knife or Scissors
- Pliers
- Carpenter's Level
- Tape Measure

RECOMMENDED TIME SAVERS

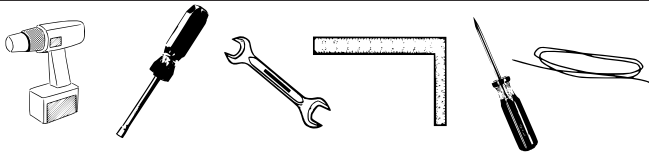

- Power Drill (Cordless, Variable Speed)
- Nut Driver or Wrench
- Square
- String (for squaring the frame)
- Awl (to align holes)

BASE PREPARATION TOOLS

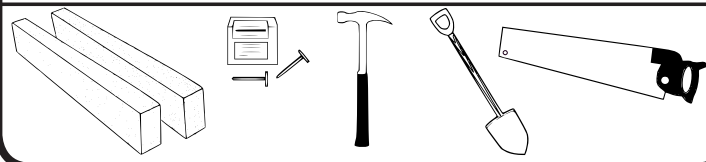

- Lumber and/or Concrete
- Hammer and Nails
- Spade or Shovel
- Hand Saw or Power Saw

How to Select and Prepare Your Building Site: Before you start to assemble your building, you will want to decide on a good location. The best location is a level area with good drainage.

- Allow enough working space so it is not difficult to move parts into position for assembly. Be sure there will be enough space at the entrance for the doors to completely open. Also, there needs to be enough space outside the building to be able to fasten the panel screws from the outside.
- Before assembling any parts, your base should be constructed and an anchoring system should be ready to use.

FREQUENTLY ASKED QUESTIONS

Q. How long will it take to assemble the building?

A. Assembly time depends on a variety of factors, including roof design, tools available, DIY skill and the pace at which you work. Guidelines for each shed assembly are approximate AFTER completion of the base, and assume two or more people working on the assembly. Generally, you should plan on at least one day working with someone who can assist you; again, after constructing the base. Refer to the clock icons on each product page on the website for specific time estimates.

Q. How do I decide where to put my shed?

A. The key to a successful assembly is to make sure the shed will be square and level when built. The shed can be assembled directly onto level ground (grass or dirt). If you have location options, choose one that is already flat, with good drainage to control moisture. If you don't have a flat, well-drained area, you need to prepare the space. Level the area using cinder blocks, concrete, crushed gravel or other sturdy materials. Once level with good drainage, construct your base. Using a carpenter's level, make sure your base is level and free of bumps or ridges to provide good support for your building.

Q. What if I can't finish my building in one session?

A. If weather conditions change so that it becomes windy or rainy, it is recommended that you stop assembly until conditions improve. This is for your safety and for protection of the shed panels. However, do not leave your unfinished construction without first temporarily anchoring the corners of the shed to your base and placing weights, such as patio blocks or sandbags, on the floor frame. Failure to anchor the building if you leave it while partially assembled could result in irreparable damage or personal injury if the building collapses.

Q. Do I need to anchor my building?

A. Yes! Fully assembled buildings should be anchored using a permanent anchoring system. If you need to leave your building before it is completely assembled, you will need to temporarily anchor the corners of the shed to your base, and place weights, such as patio blocks or sandbags, on top of the floor frame.

Note: If you have to stop assembly for any reason before it is complete, do not leave your unfinished construction without first temporarily anchoring the corners of the shed to your base and placing weights, such as patio blocks or sandbags, on the floor frame.

Q. How do I temporarily anchor my building before it's fully assembled?

A. An incomplete building must be anchored before breaking for any period of time to prevent possible damage.

- If the building is on a wood base, secure the frame with wood screws in the corners
- If the building is on a concrete base, temporarily anchor the frame in the corners
- Use patio blocks or sandbags on top of the floor frame as weights
- Secure the floor frame to the ground with ground augers or rope the frame in the corners to the ground

Q. How do I control condensation and prevent water from leaking in?

A. To minimize condensation, install a continuous, unbroken plastic vapor barrier with a thickness of 6 mil. between exposed ground surface and the building's base. Make sure that all weather stripping and washers are used throughout the assembly process. Make sure that the weather-stripping tape adheres to the panels when installing it along the main ridge beam. Do not stretch it. Apply it directly off the roll onto clean panels. Ensure that all washers are flush with the panels and do not over-tighten screws, as this can crack the washers. Silicone caulking may be used to create watertight seals at the washers and throughout the building.

Q. What kind of base do I use?

A. You can:

- Pour a concrete slab
- Build a wood deck/floor (use exterior-grade plywood)
- Use patio blocks
- Build on crushed gravel, dirt or grass

Q. How should I measure for my base?

A. Shed dimensions are provided in “nominal” size. Nominal sizes are roof-edge measurements rounded to the nearest foot and are not the measurements to use for constructing the shed base. So, carefully check the exact, recommended base size in the specifications for your shed model.

Q. Can the building be painted?

A. The buildings can be painted with an exterior-grade paint designed for use on steel. Contact your local paint supplier for recommendations.

Q. How do I take care of dents in my shed?

A. Proper selection of shed size, including a sufficient door-opening width, and proper placement of your shed should minimize the possibility of damage. If a dent does occur, carefully push the dent out from the opposite side. If the paint has been scratched or removed, touch up the area as soon as you notice it. Immediately clean the area with a wire brush or emery paper, wash it and apply touch-up paint. This will minimize rust and maintain your shed's attractive appearance for years.

At the top of each page you will see one or more **Part Cues** like the one to the left. These **Part Cues** are designed to help you quickly identify the parts needed for each step.

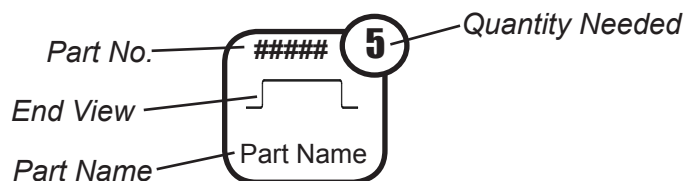

Confirm that all hardware and parts are present before attempting to assemble your building.

If parts are missing or damaged, include the model number and contact the retailer where you purchased your Storage Unit.

Part Numbers

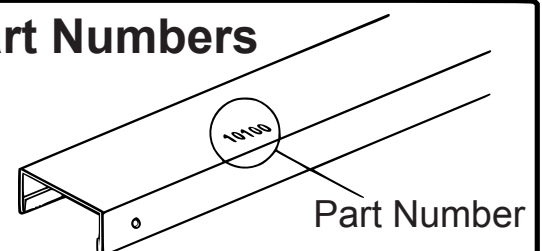

1. Each part has an identifying part number on it.
2. Part Numbers are referenced in each step.
3. Unpainted parts have a stamped in number and painted parts have a number that is inked on.

Remove inked on numbers with soap and water after assembly.

HARDWARE LIST...

Key No.	Part No.	Part Description	Qty.	✓ List
1	65103	Hex Nut (#8-32)	50	
2	65923	Small Bolt (Black) (#8-32 x 3/8) (10 mm)	38	
3	65004	Small Screw (Black) (#8AB x 5/16) (8 mm)	115	
4	65958	Long Bolt (#8-32 x 7/8) (22 mm)	6	
5	65988	Flat Head Bolt (#6-32 x 5/16) (8 mm)	48	
6	65941	Hex Nut (#6-32)	48	
7	66611	Tapping Screw (#10 x 1/2) (13 mm)	6	
8	66646	Washer Sheet	2	
9	66809	Locking Handle	1	
10	66054	Latch	1	
11	66609	Hinge	8	
12	66849L	Left Jamb Cap	1	
13	66849R	Right Jamb Cap	1	
14	66848	Lid Corner Cap	4	
15	66785	Lid Stay	3	
16	11029	Adhesive Pads	3	
17	66850	Bar Locking Assembly	1	
18	66861L	Left Rear Corner Cap	1	
19	66861R	Right Rear Corner Cap	1	
20	66658	Bracket-Camrod	1	
21	66862	Slam Bolt	1	
22	8397	Corner Brace	4	
23	10961	Mounting Plate	3	
24	6481	Gusset	4	
25	11042	Mounting Plate (Slam Bolt)	1	

Hardware Views by Key No.

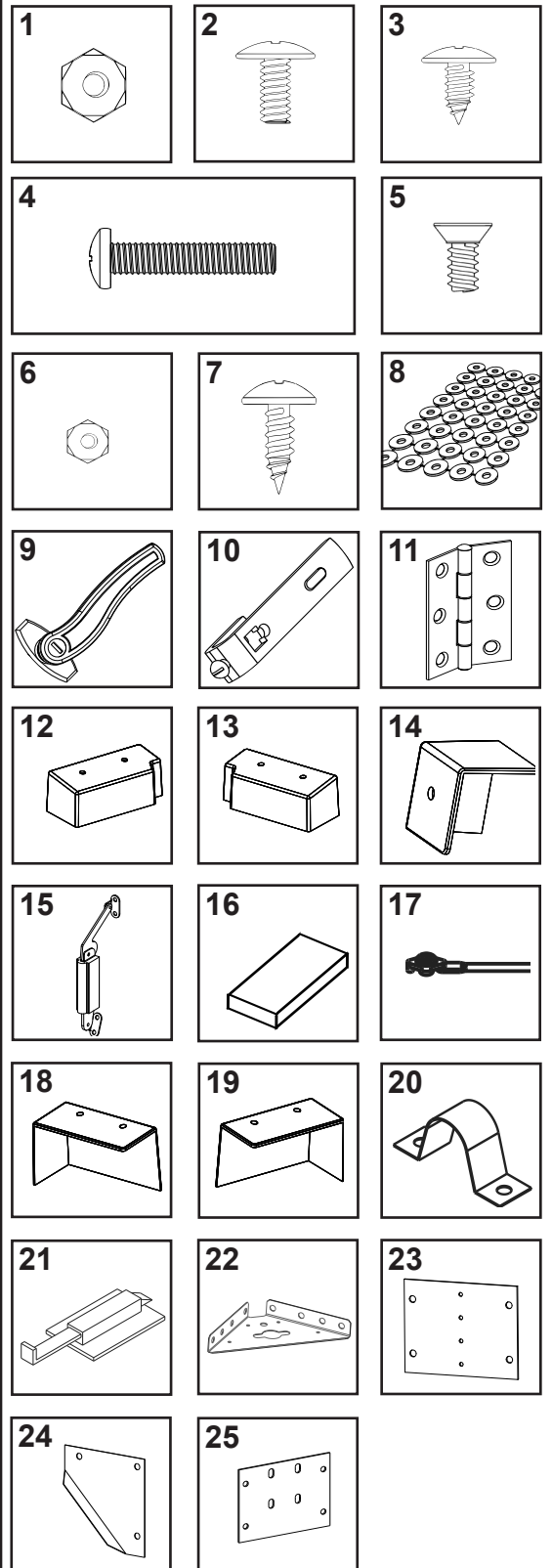

The fasteners used in each step are shown actual size at the top of each page. If you are unsure which fastener to use, hold it up to the picture and use the one that matches.

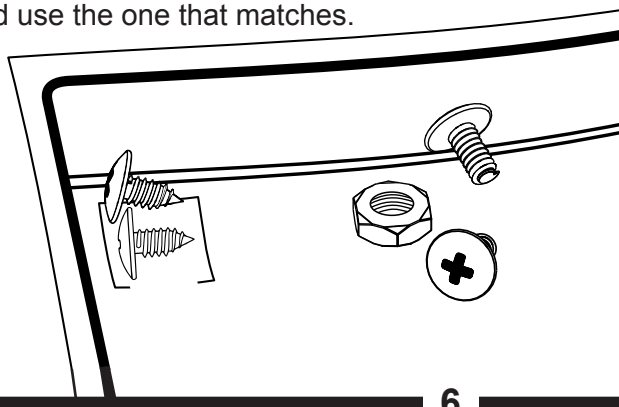

PARTS LIST...

Key No.	Part No.	Part Description	Qty.	✓ List
26	10954	Corner Post	2	
27	11072	Rear Wall Brace	3	
28	10967	Channel Wall Rear	1	
29	10960	Door Jamb	2	
30	10963	Brace Door Vertical	1	
31	10964	Channel Side Wall	2	
32	11104	Frame Floor Front-Rear	2	
33	10971	Channel Lid Rear	1	
34	10970	Channel Lid Front	1	
35	10981	Channel Lid End	2	
36	10973	Lintel	1	
37	10983	Lid Brace	3	
38	10984	Frame Floor Side	2	
39	10968	Horizontal Door Brace	4	
40	10959	Door Stop	3	
41	11007	Ramp	1	
42	69835	Edge Trim	1	
43	11074	Panel Rear	2	
44	10958	Panel Gable Right	1	
45	10972	Door Right	1	
46	80097	Panel Gable Left	1	
47	80103	Door Left	1	
48	8827	Panel Side	2	
49	10969	Panel Lid	1	
50	66855	Outer Lid Foam Board	2	
51	66853	Center Lid Foam Board	2	
52	66854	Door Foam Board	2	

Selected End Views by Key No.

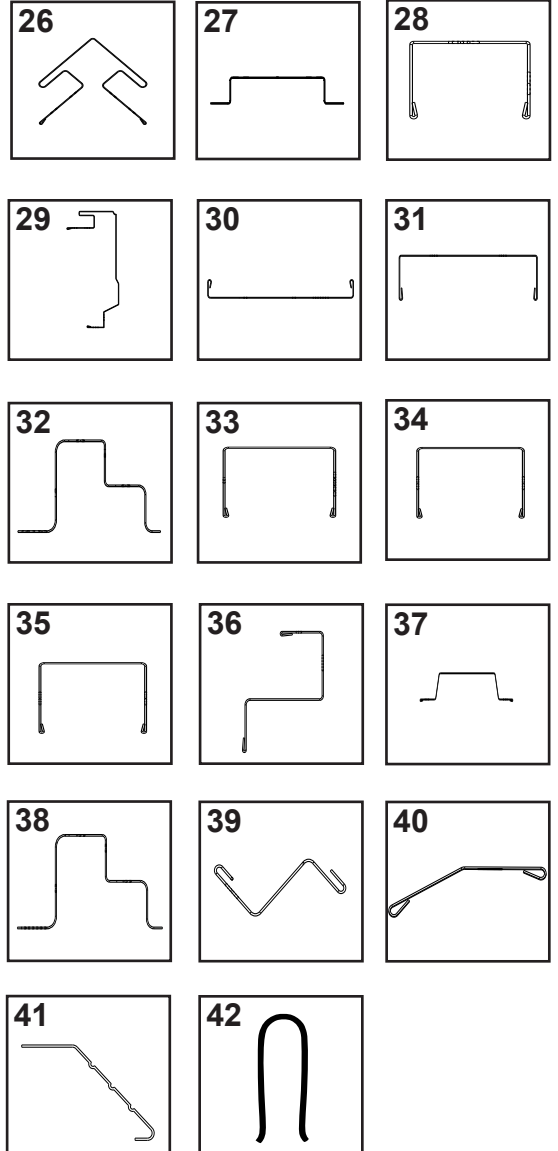

ASSEMBLY BY KEY NO.

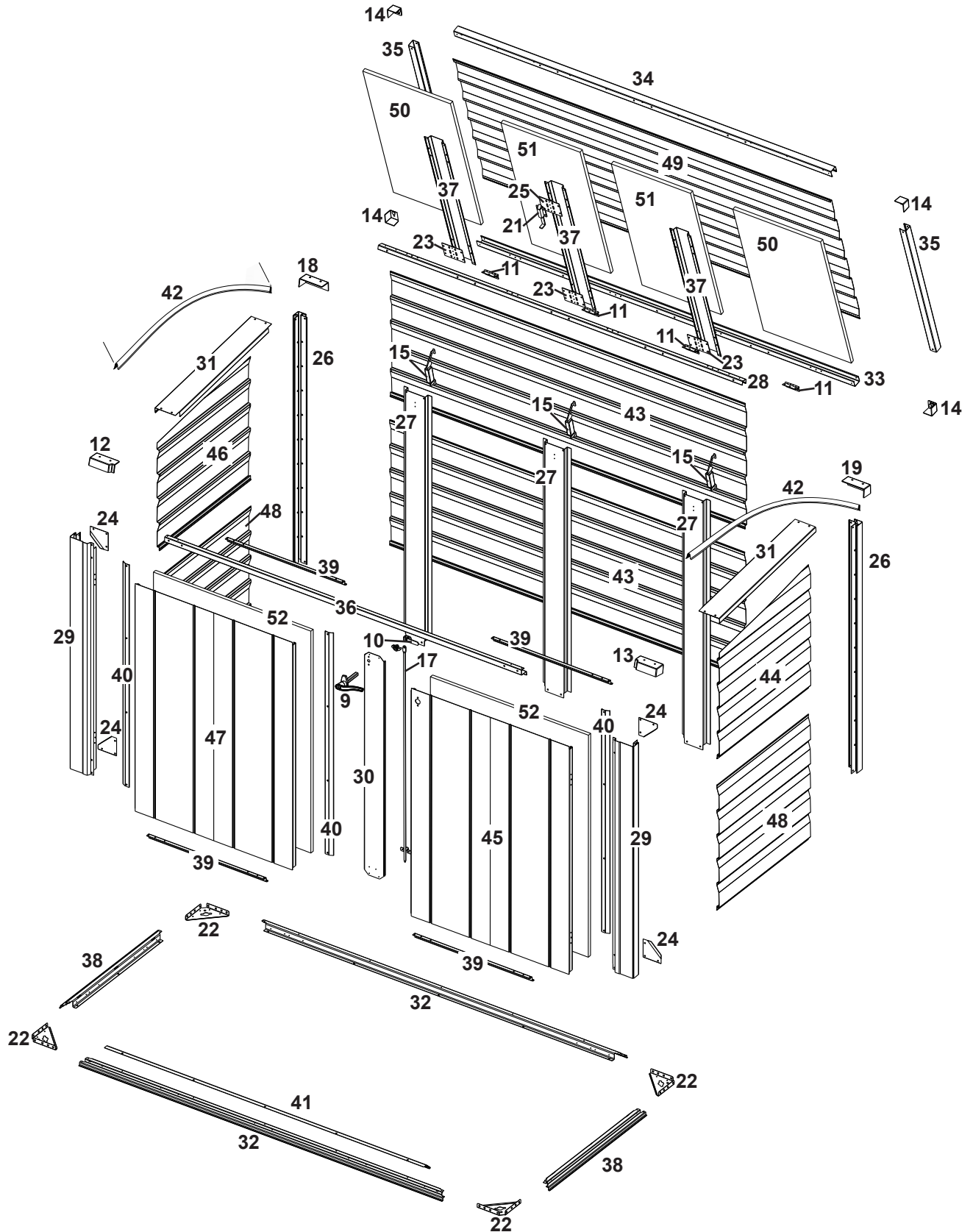

ASSEMBLY OVERVIEW

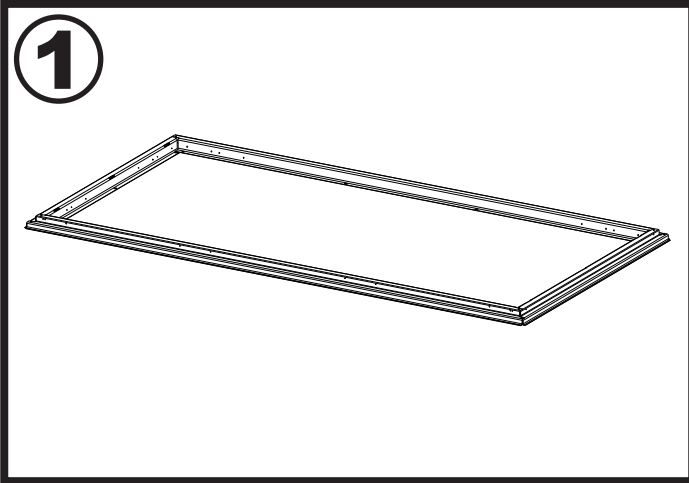
1

Build the Floor Frame

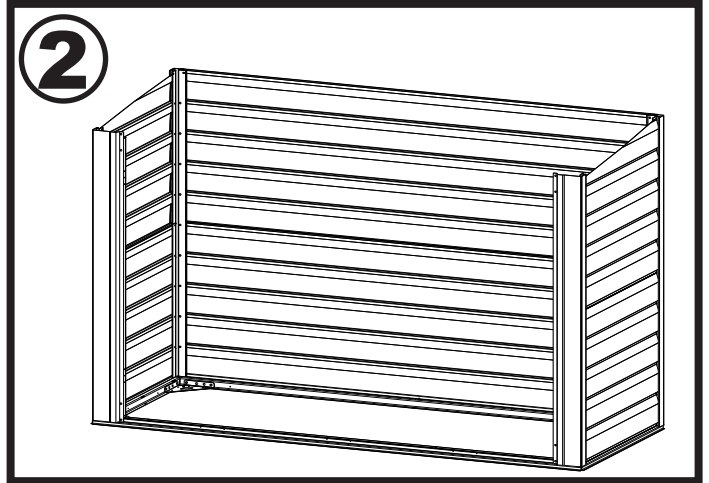
2

Install Posts and Wall Panels

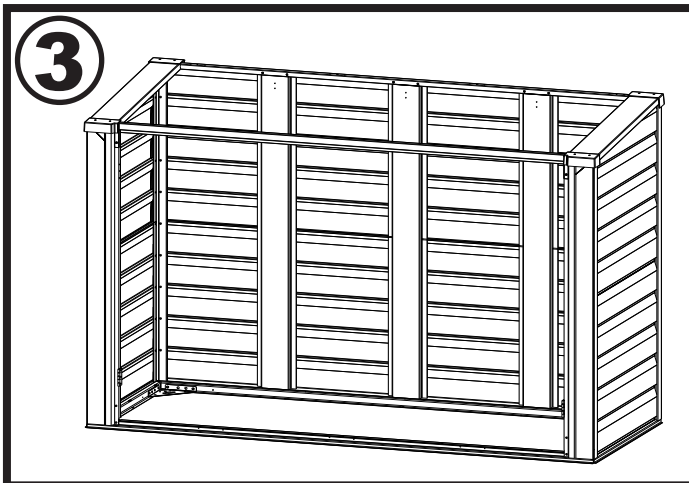
3

Install Side Channel, Rear Channel, & Lintel

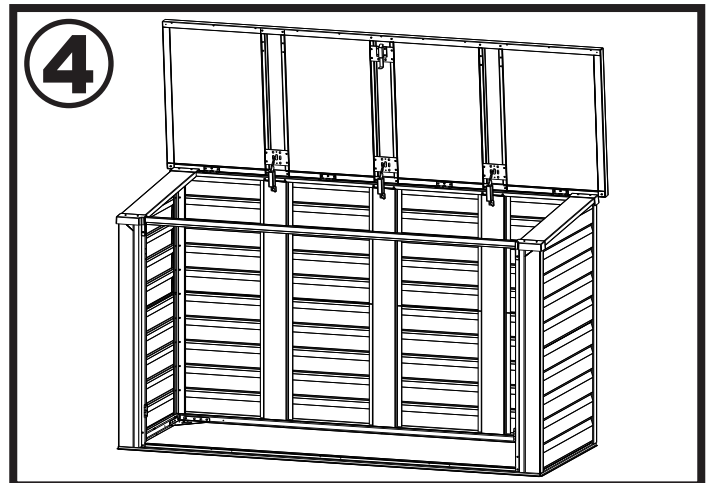
4

Install Lid

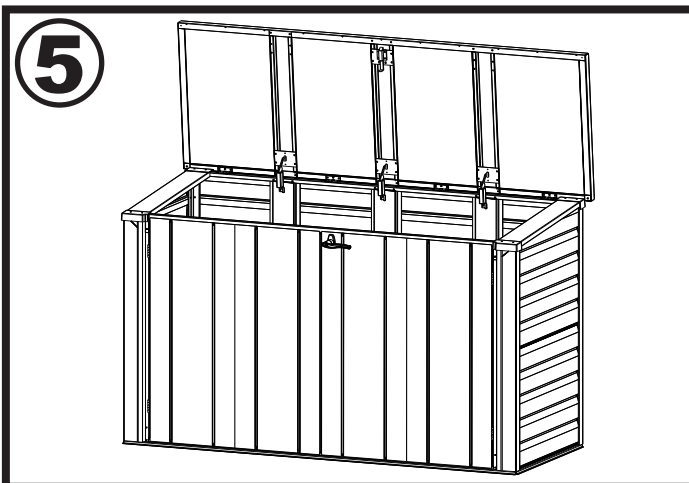
5

Install Doors

CONSTRUCTING A BASE...

No matter which of the options below you choose for a base, an ARROW ANCHORING KIT is recommended as an effective method of properly securing your building after assembly is complete.

OPTION 1: Directly on ground (earth)

Assemble your building directly on level ground (grass, dirt, rock, sand, etc.).

OPTION 2: Wood Platform

If you decide to build your own base, be sure to select the appropriate materials.

These are the recommended materials for your base:

- 2 x 4's (38 mm x 89 mm) Pressure Treated Lumber
- 5/8" (15,5 mm) 4 x 8 (1220 mm x 2440 mm) Plywood-exterior grade
- 10 & 4 penny Galvanized Nails
- Concrete Blocks (optional)

NOTE: Pressure Treated Lumber must not be used where it will make contact with your storage building. The properties of Pressure Treated Lumber will cause accelerated corrosion. **If Pressure Treated Lumber comes in contact with your storage building your warranty will be voided.**

The platform should be level and flat (free of bumps, ridges etc.) to provide good support for the building. The necessary materials may be obtained from your local lumber yard.

To construct the base follow instructions and diagram.

- Construct frame (using 10 penny galvanized nails)
- Measure 16"/24" (40,6 cm/61,0 cm) sections to construct inside frame (see diagram)
- Secure plywood to frame (using 4 penny galvanized nails)

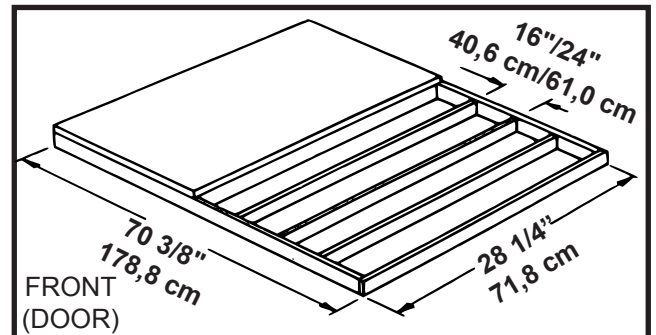

Note: Platform/Slab will extend 9/16" (1,4 cm) beyond floor frame on all four sides. Seal this 9/16" (1,4 cm) of wood with a roofing cement (not included), or bevel this 9/16" (1,4 cm) of concrete when pouring, for good water drainage.

OPTION 3: Concrete Slab

The slab should be at least 4" (10,2 cm) thick. It must be level and flat to provide good support for the frame.

The following are the recommended materials for your base.

- 1 x 4's (19 mm x 89 mm) (will be removed once the concrete cures)
- Concrete
- Sheet of 6 mil plastic
- We recommend for a proper strength concrete to use a mix of:
1 part cement • 3 parts pea sized gravel • 2 1/2 parts clean sand

Prepare the Site/Construct a Base

1. Dig a square, 6" (15,2 cm) deep into the ground (remove grass).
2. Fill up to 4" (10,2 cm) in the square with gravel and tamp firm.
3. Cover gravel with a sheet of 6 mil plastic.
4. Construct a wood frame using four planks of 1x4 (19 mm x 89 mm) lumber.
5. Pour in concrete to fill in the hole and the frame giving a total of 4" (10,2 cm) thick concrete. Be sure surface is level.

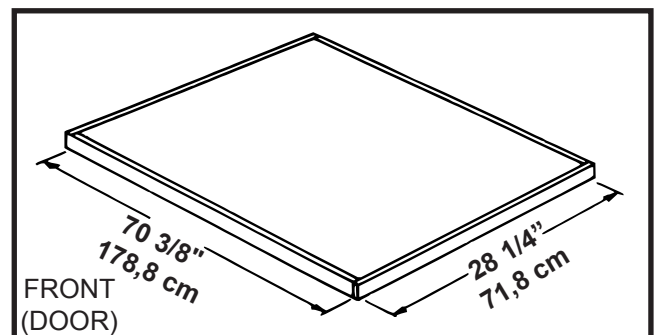

Note: Finished Slab dimensions, with lumber removed.

Step 1: Frame Assembly

You will need for this page:

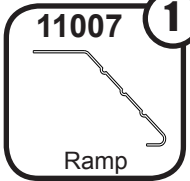
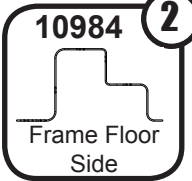
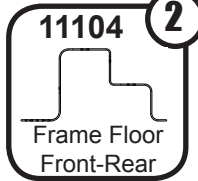
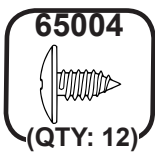

NOTE Do NOT fasten your Floor Frames to your Base at this time. You will anchor your building after it is erected.

1

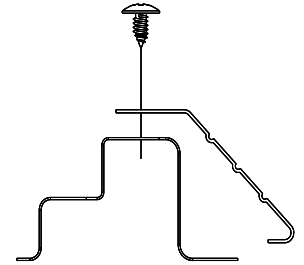
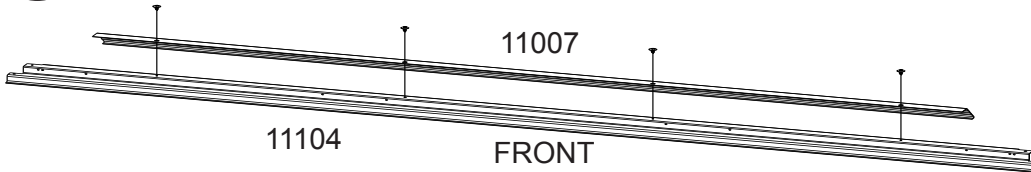

2

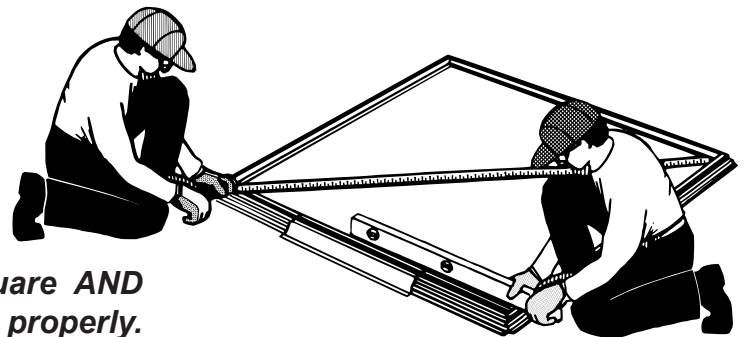
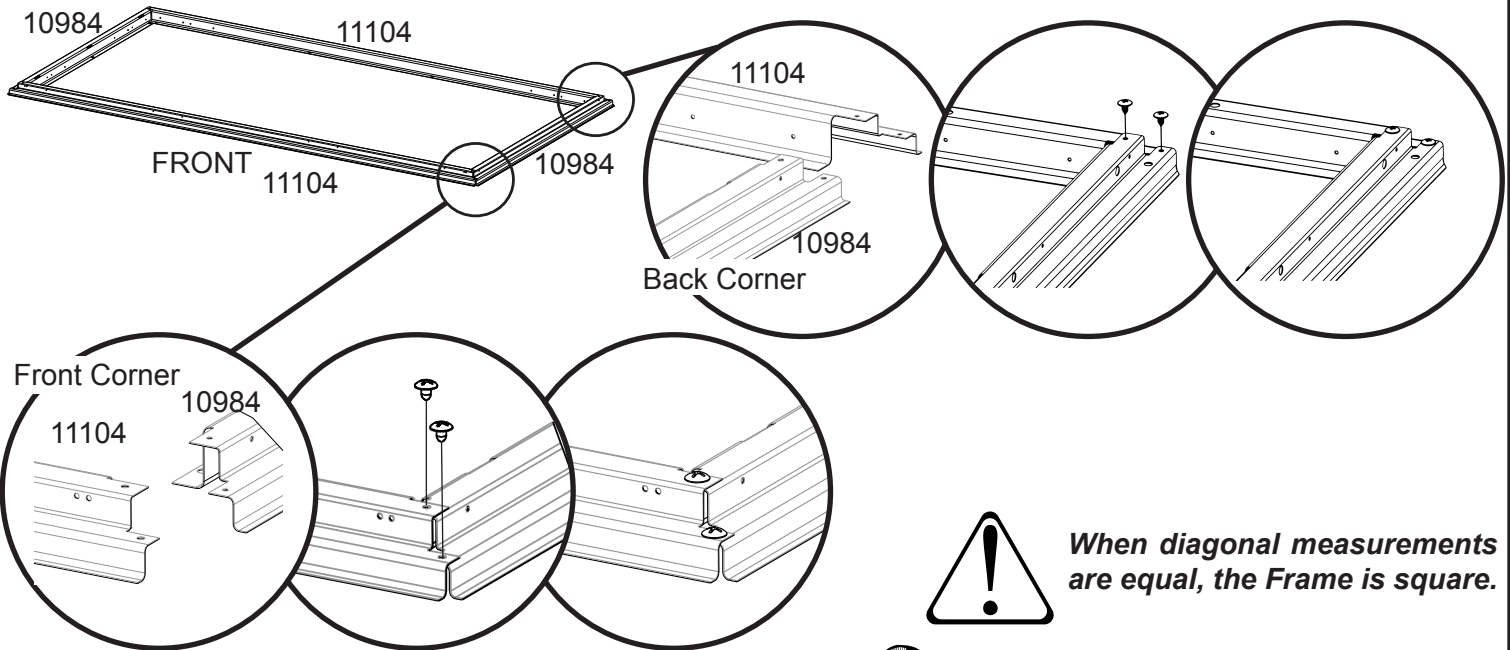

The Floor Frame must be BOTH square AND level or the holes will not line up properly.

Step 1: Frame Assembly

You will need for this page:

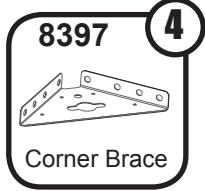
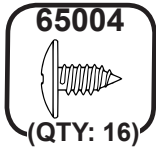

3

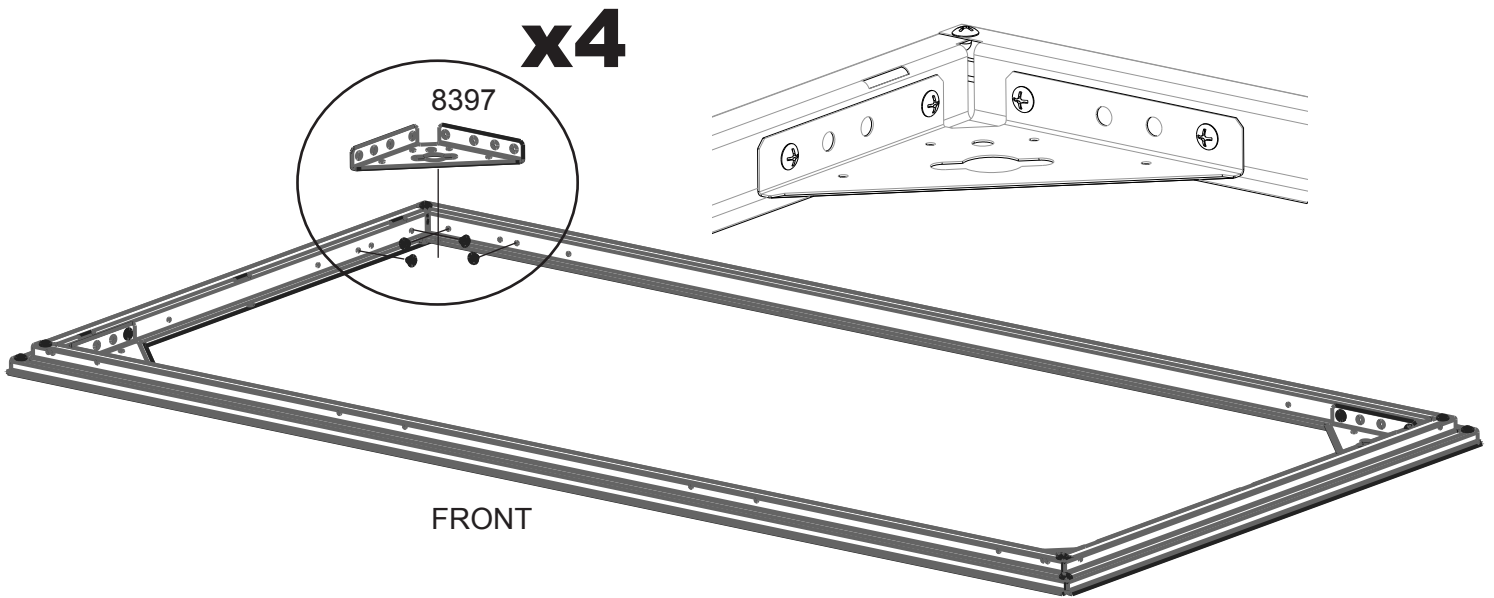

Step 2: Rear Channel Lid Assembly

You will need for this page:

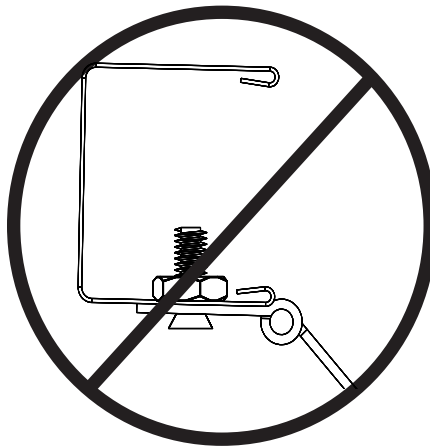
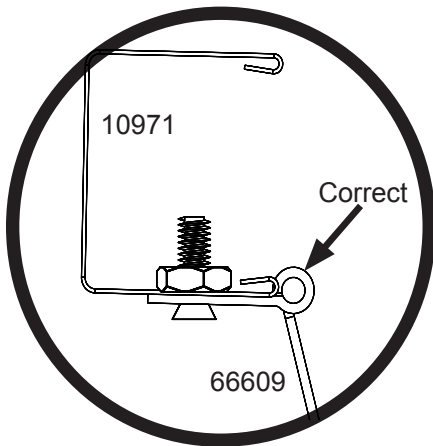
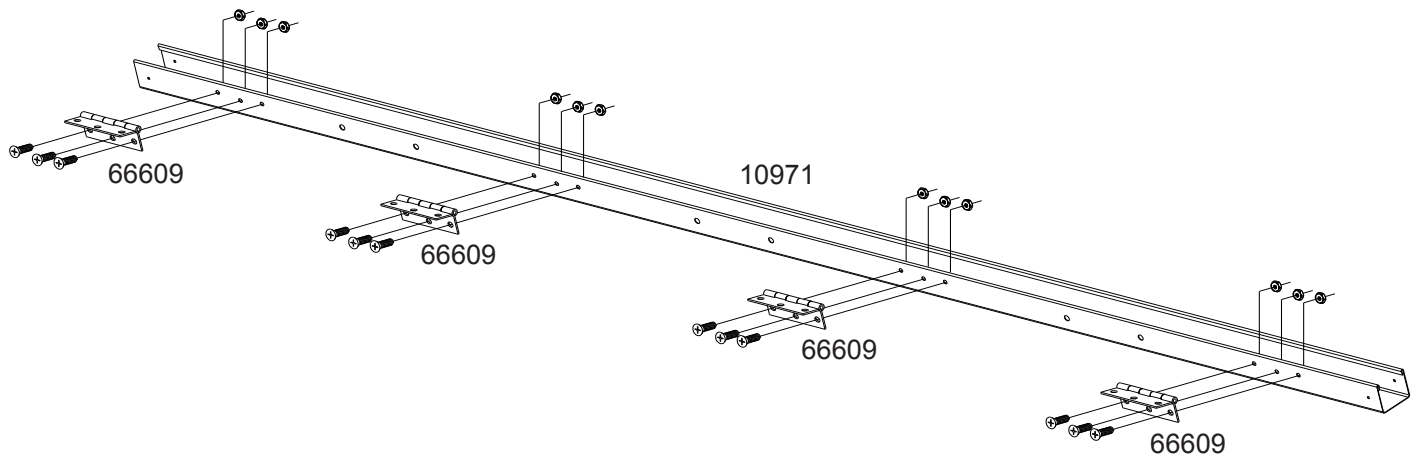
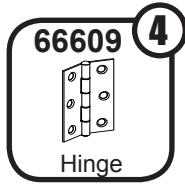
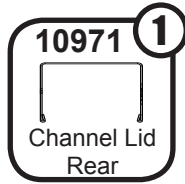
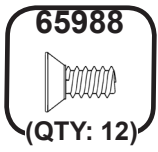

Step 3: Lid Brace Assembly

You will need for this page:

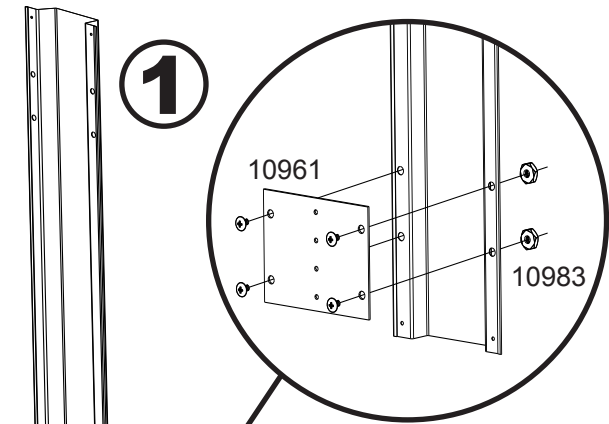
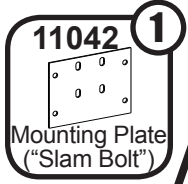
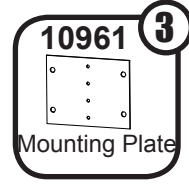
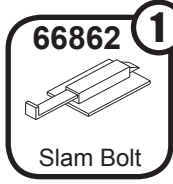
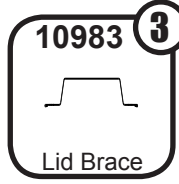
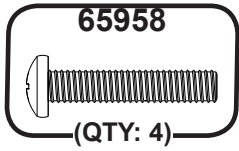
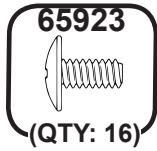

x3

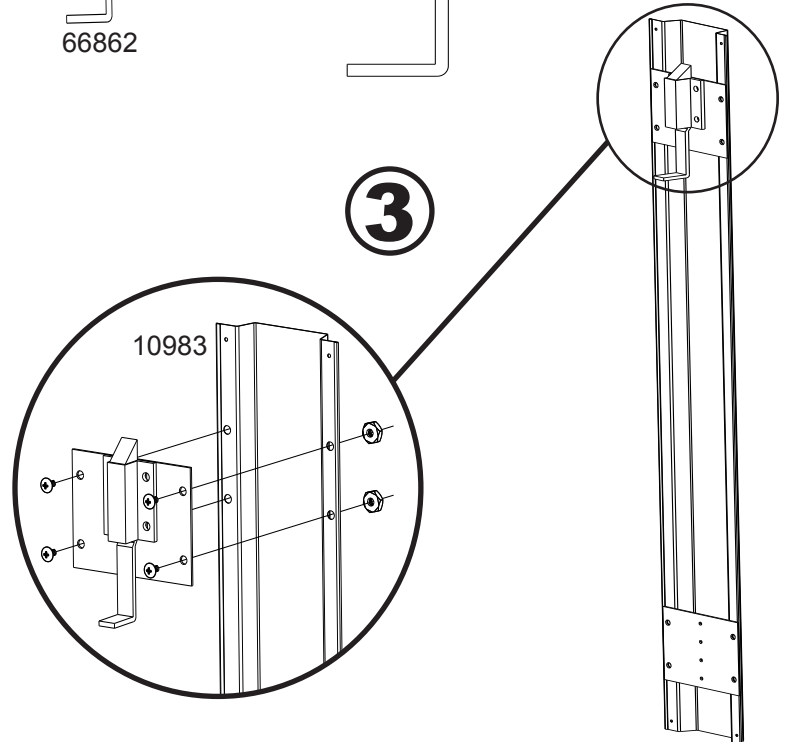
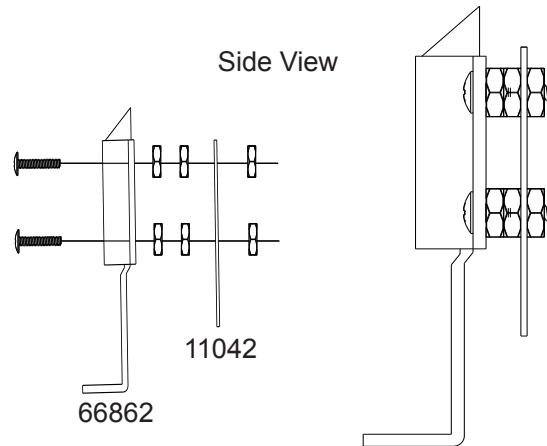
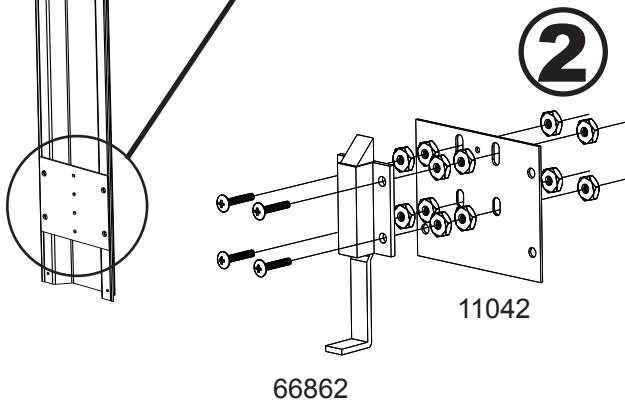

Step 4: Rear Wall Brace Assembly

You will need for this page:

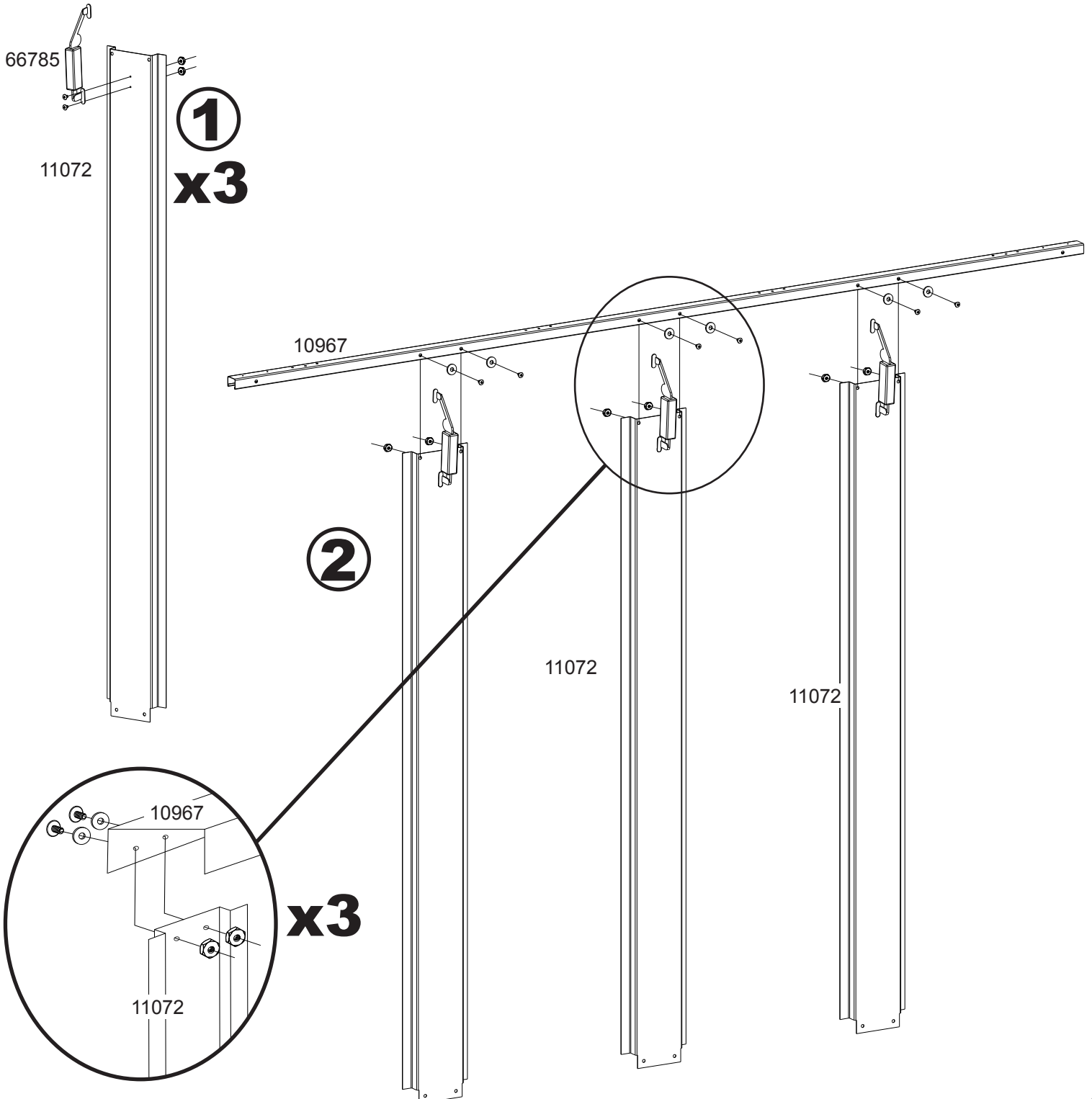
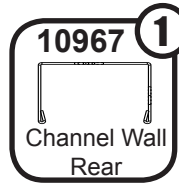
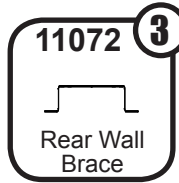
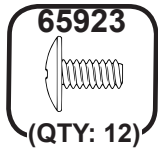

Step 5: Lid Assembly

You will need for this page:

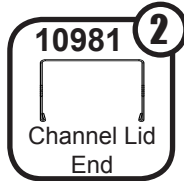
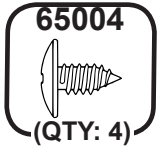

Assembly from Step 2:

- Rear Channel Lid Assembly

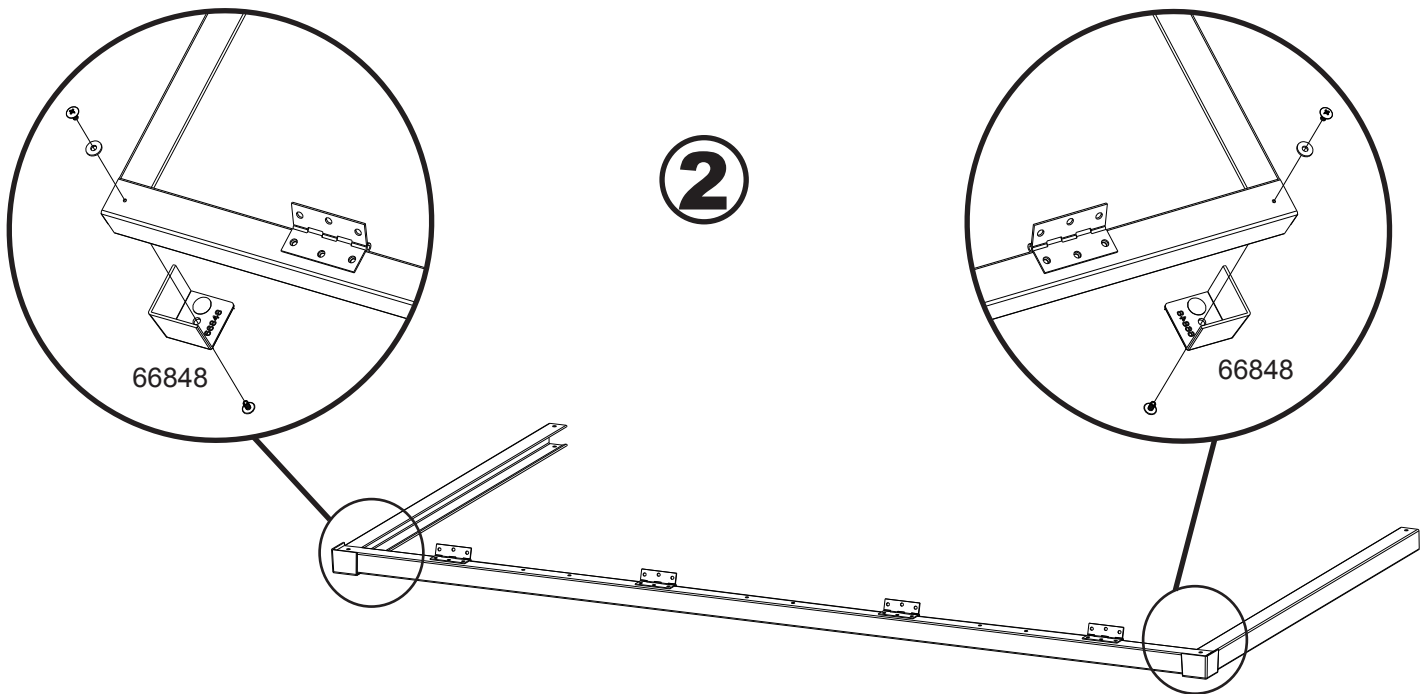
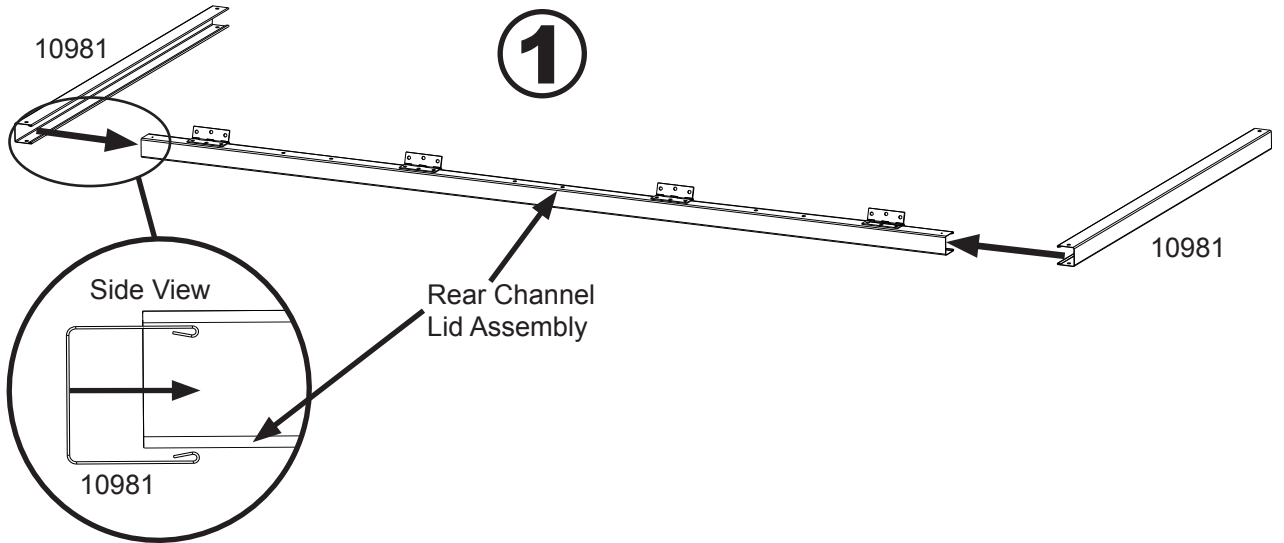

Step 5: Lid Assembly

You will need for this page:

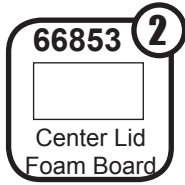
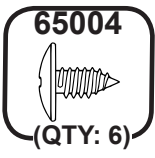

Assembly from Step 3:

- Lid Brace Assemblies

3

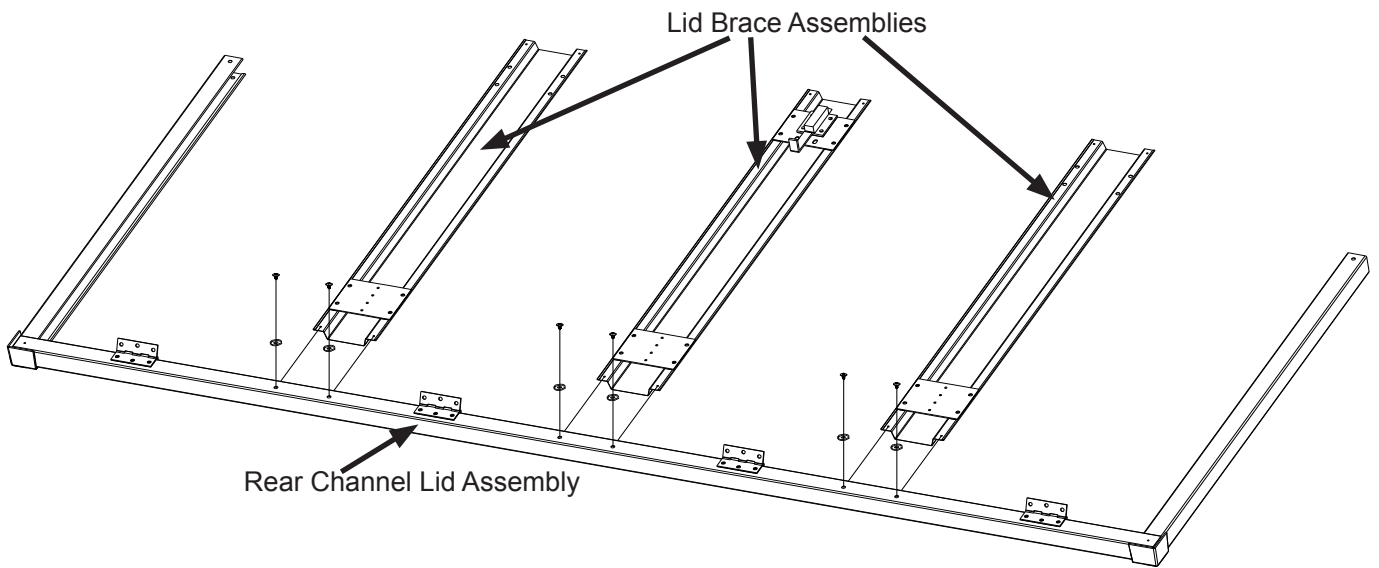

4

NOTE Place Foam "Foil Side" Up.

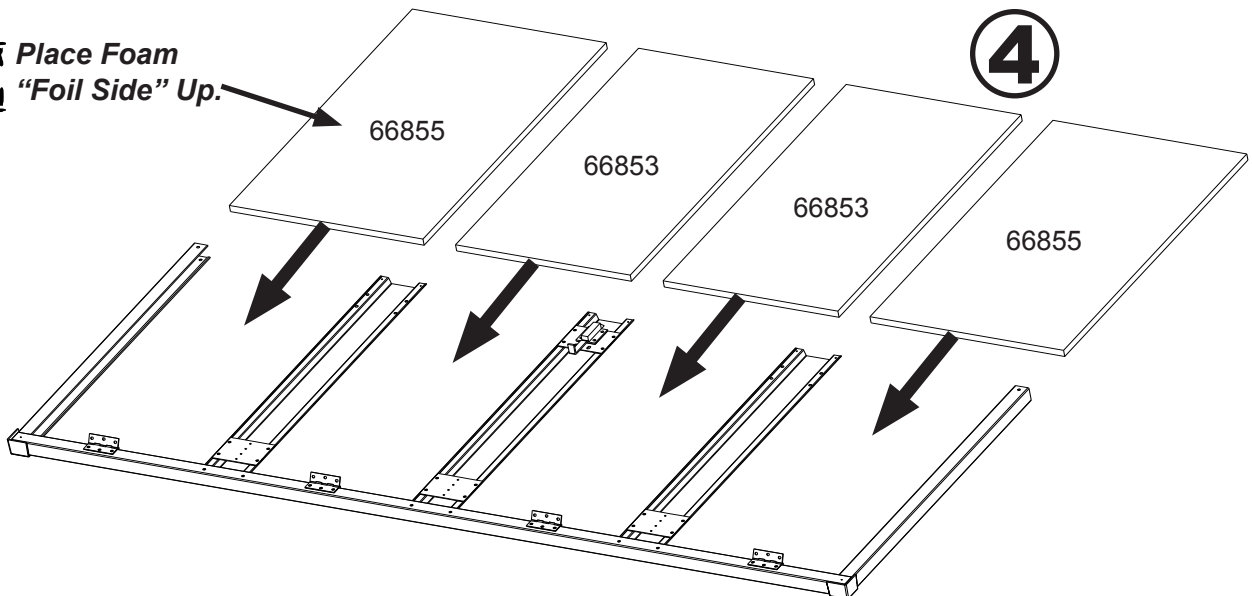

Step 5: Lid Assembly

You will need for this page:

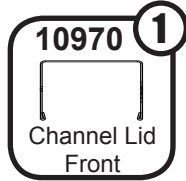
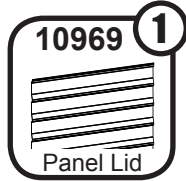
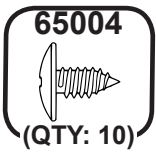

5

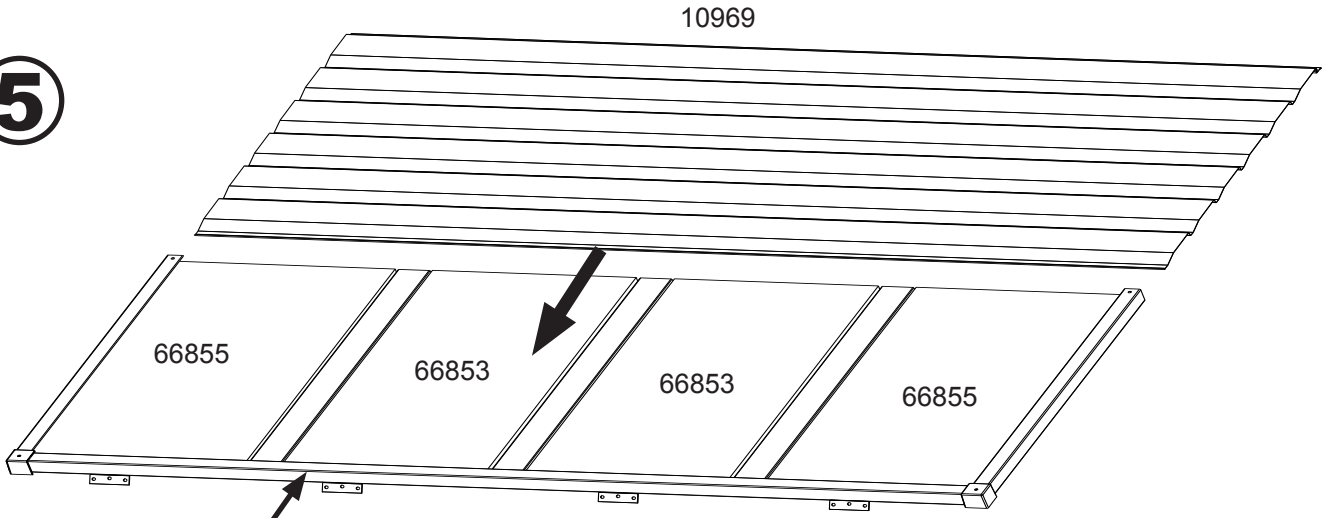

NOTE

Rear Channel Lid Assembly

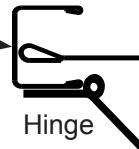

10969 Panel Lid

6

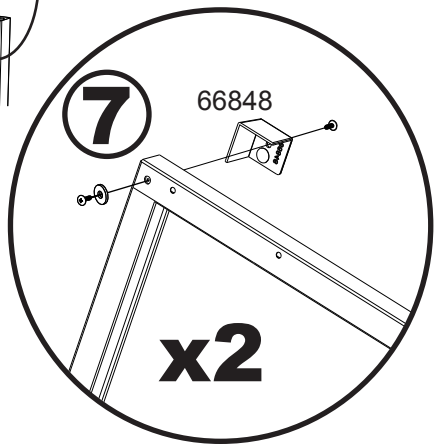
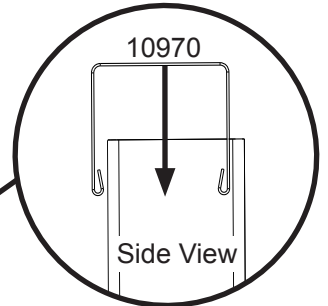
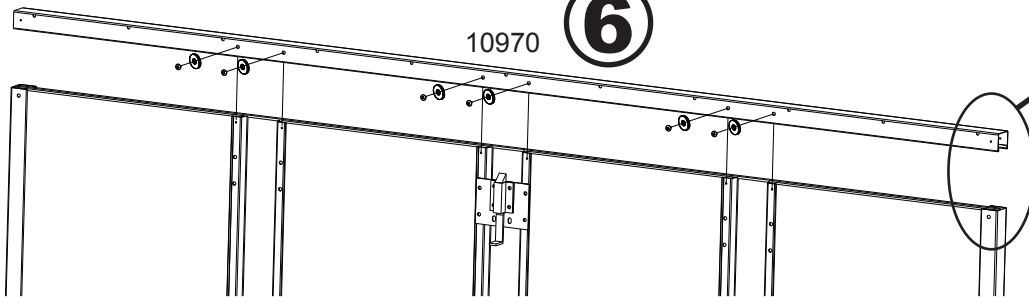

Step 6: Door Assembly (Left)

You will need for this page:

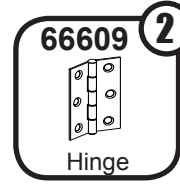
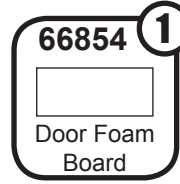
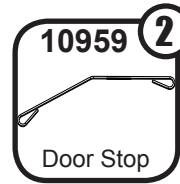
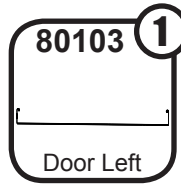
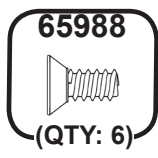
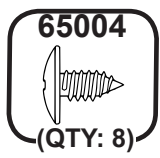

NOTE Place Foam "Foil Side" Out.

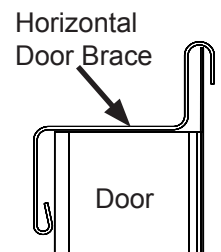
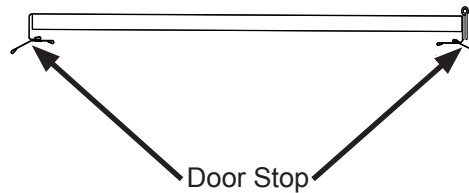
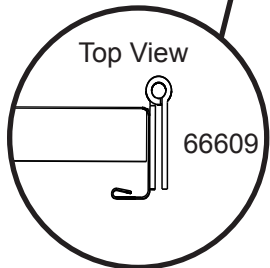
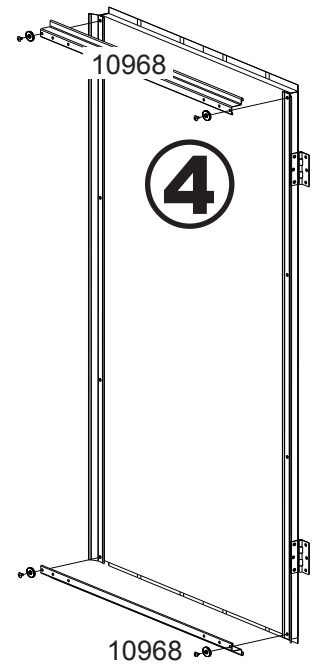
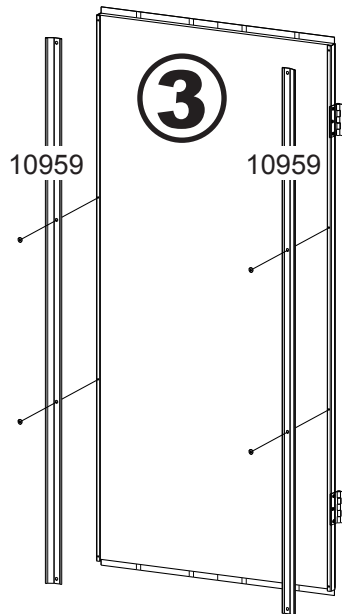
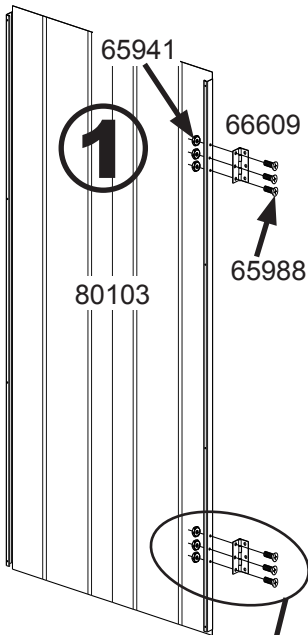

Top View

Side View

Step 6: Door Assembly (Right)

You will need for this page:

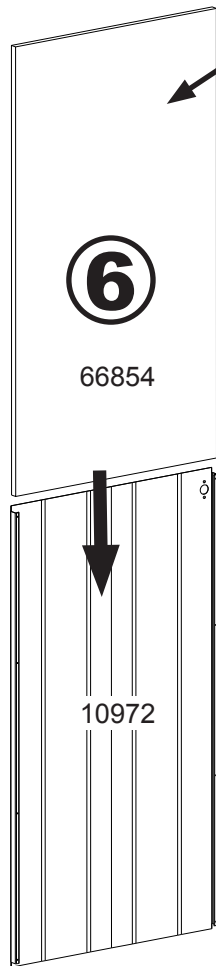
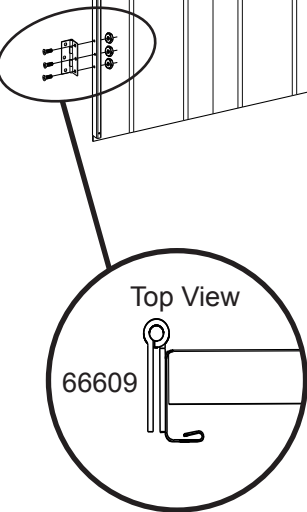
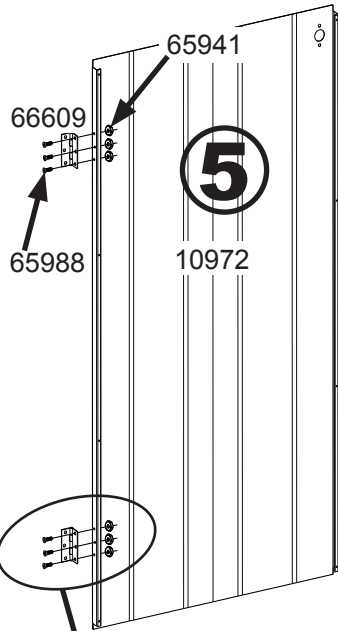
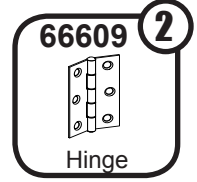
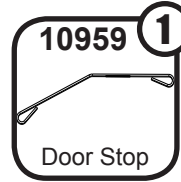
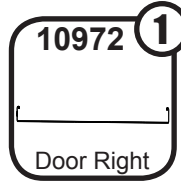
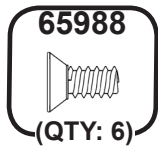

NOTE Place Foam "Foil Side" Out.

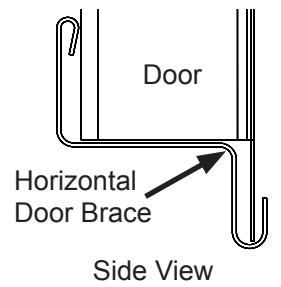
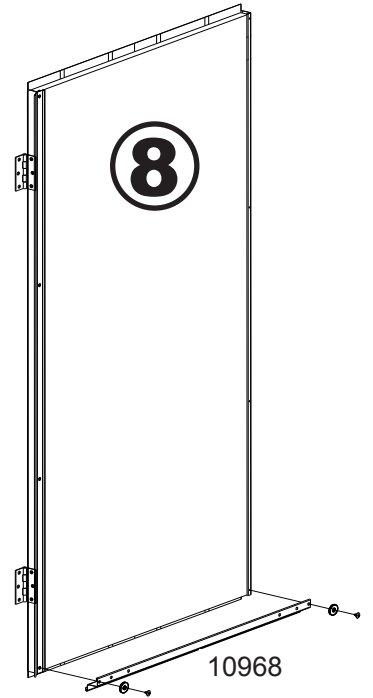
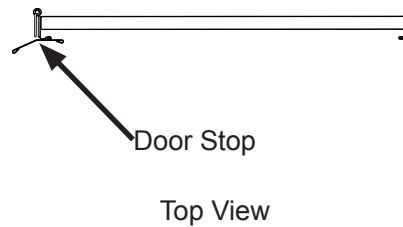
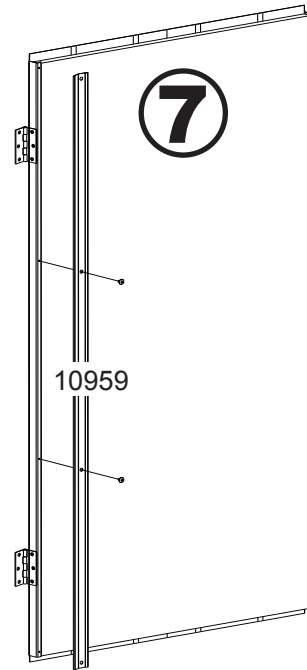

Step 7: Door Lock Assembly

You will need for this page:

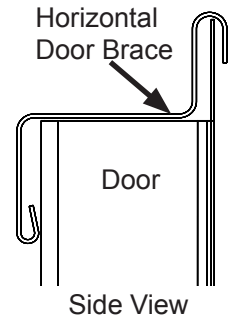
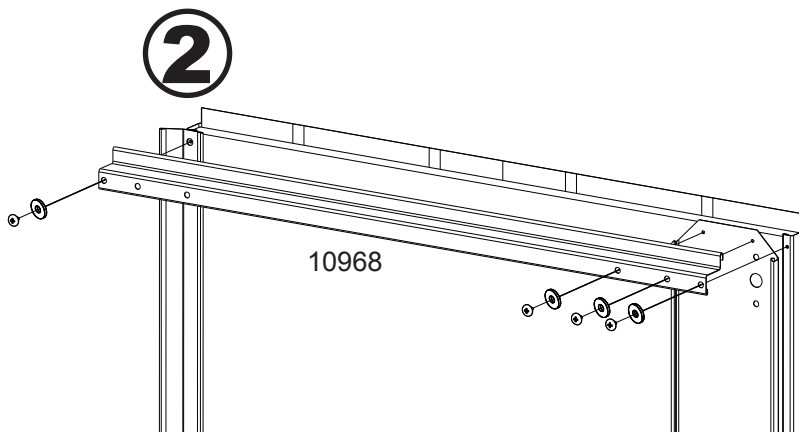
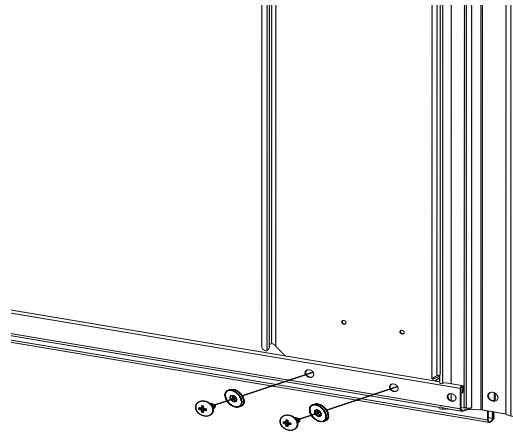
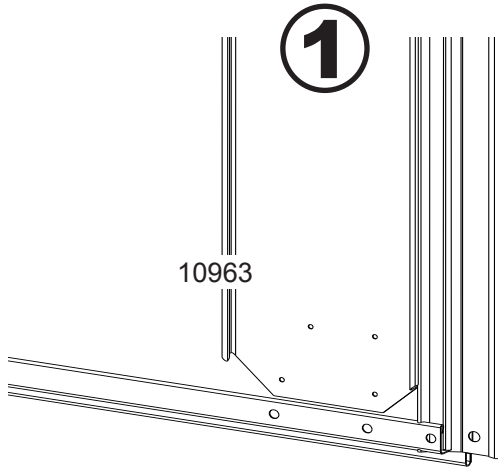

Step 7: Door Lock Assembly

You will need for this page:

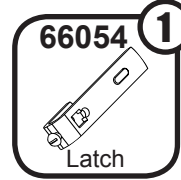
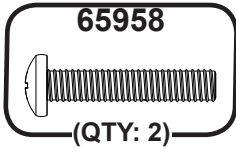

3



4

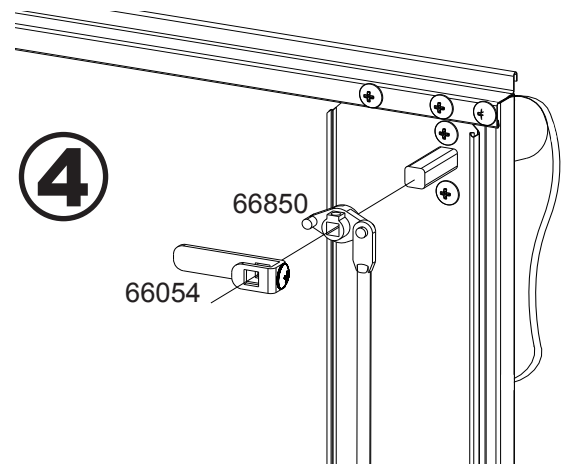

5

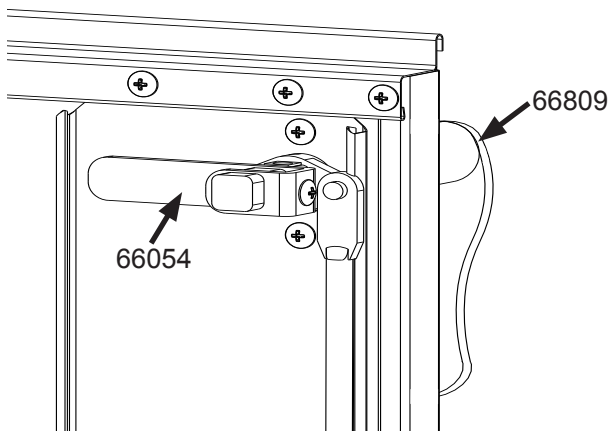

6

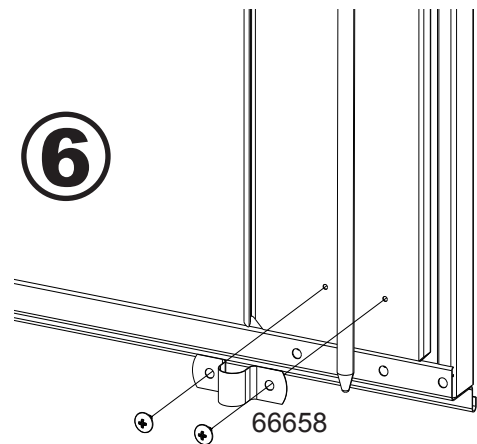

Step 8: Side Walls

You will need for this page:

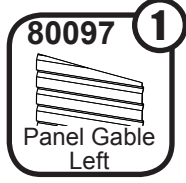
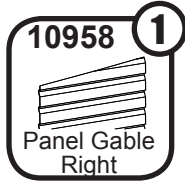
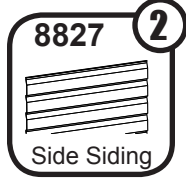
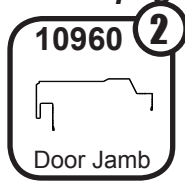
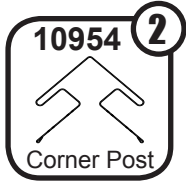

Assembly from Step 1:

- Frame Assembly

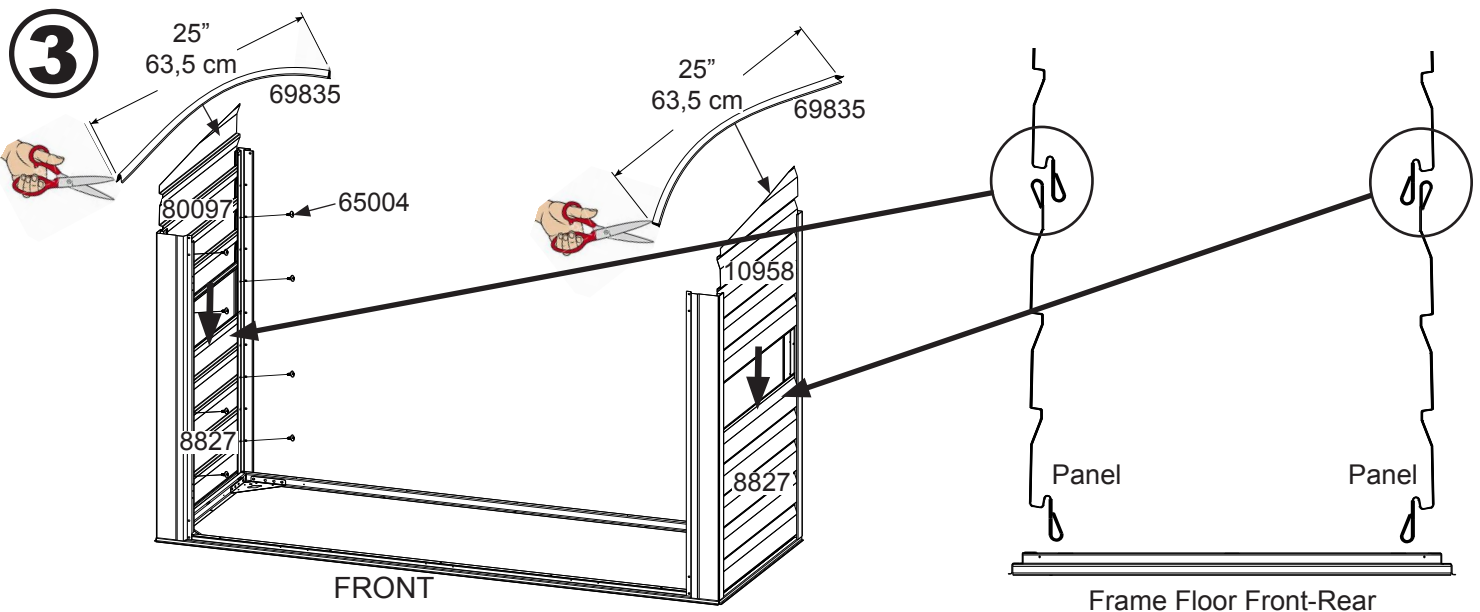
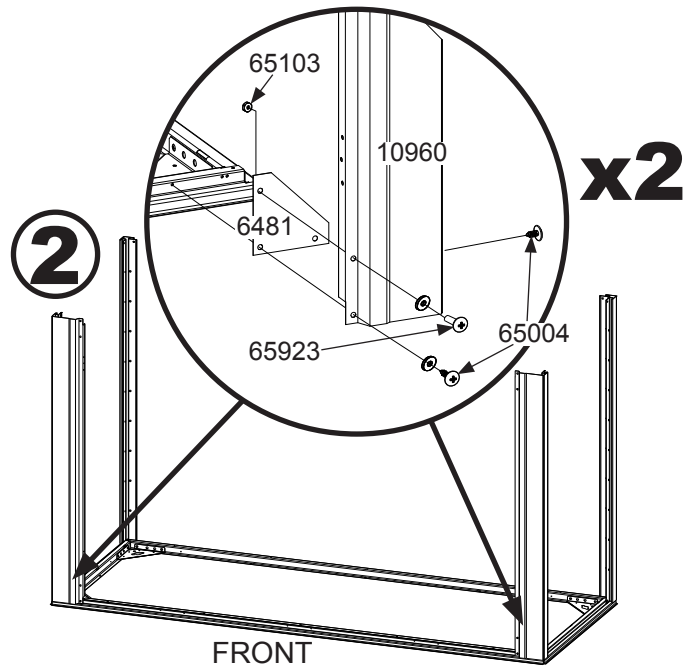
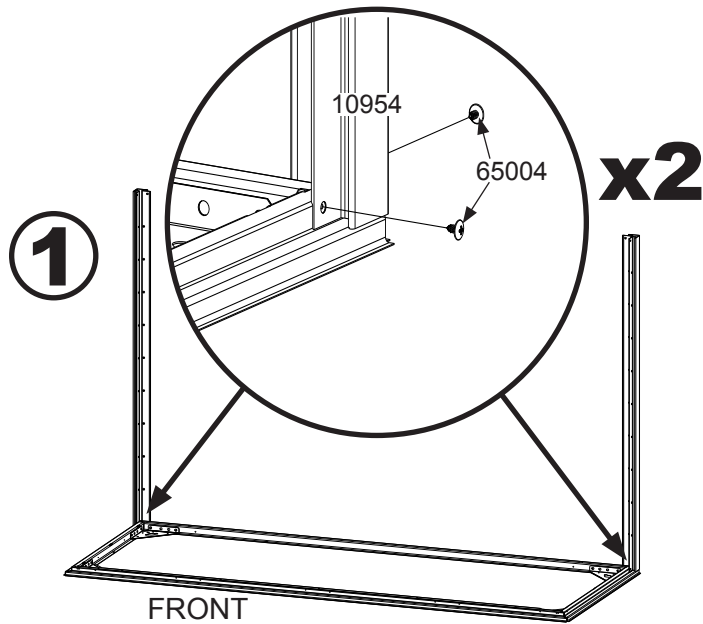
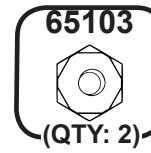
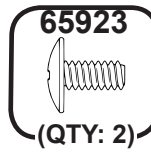
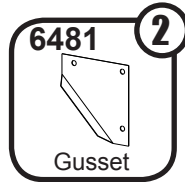
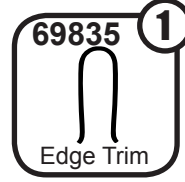

Step 9: Back Wall

You will need for this page:

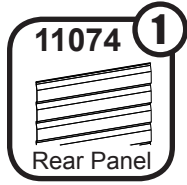
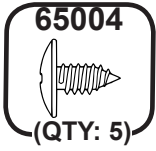

1

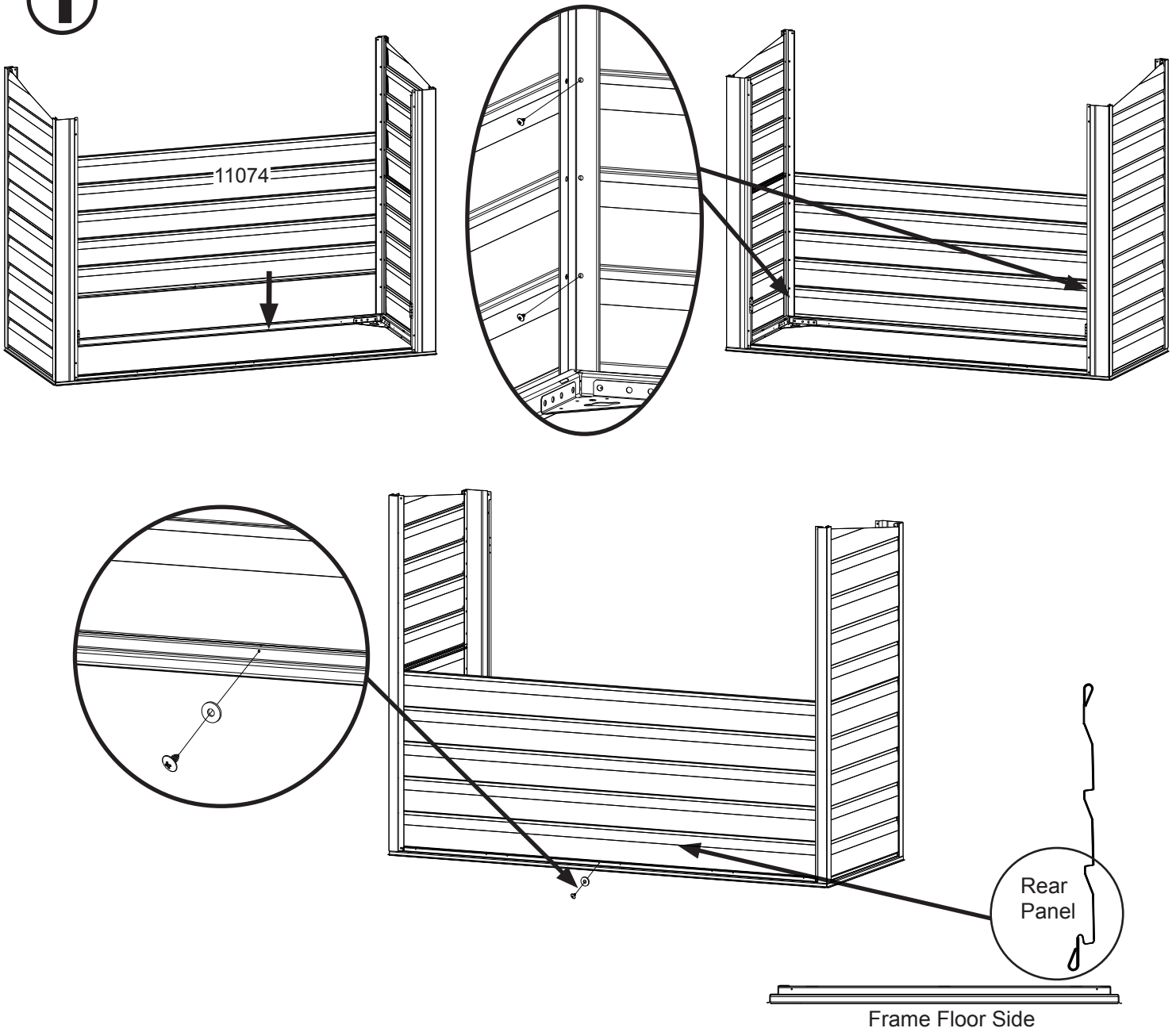

Step 9: Back Wall

You will need for this page:

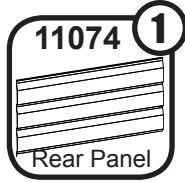

2

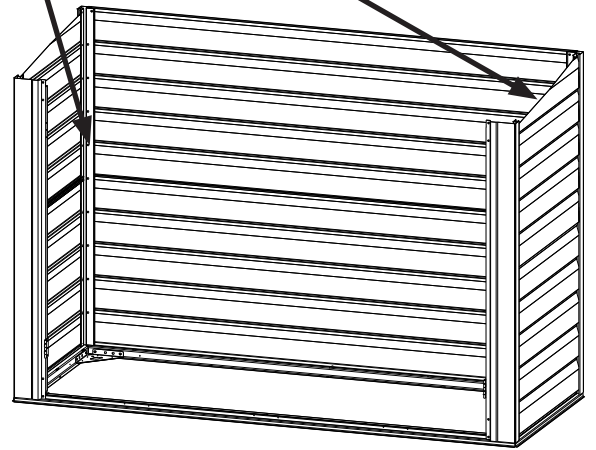
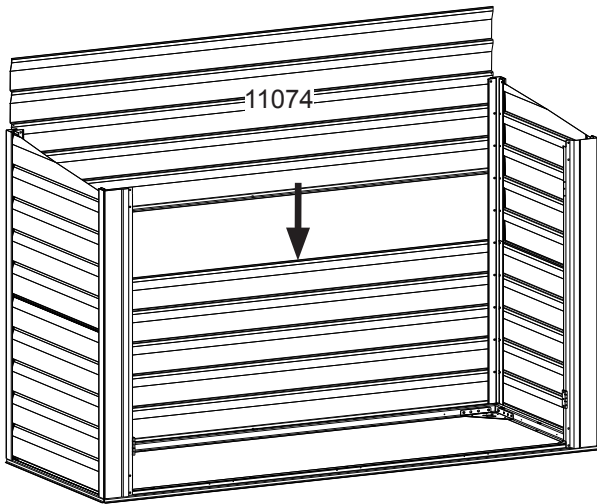
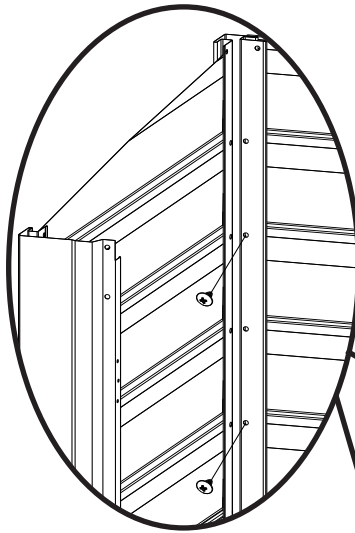

Rear Panel

Frame Floor Side

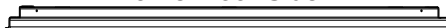

Step 10: Rear Wall Channel

You will need for this page:

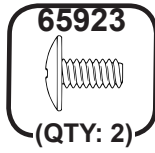

Assembly from Step 4:

- Rear Wall Brace Assembly

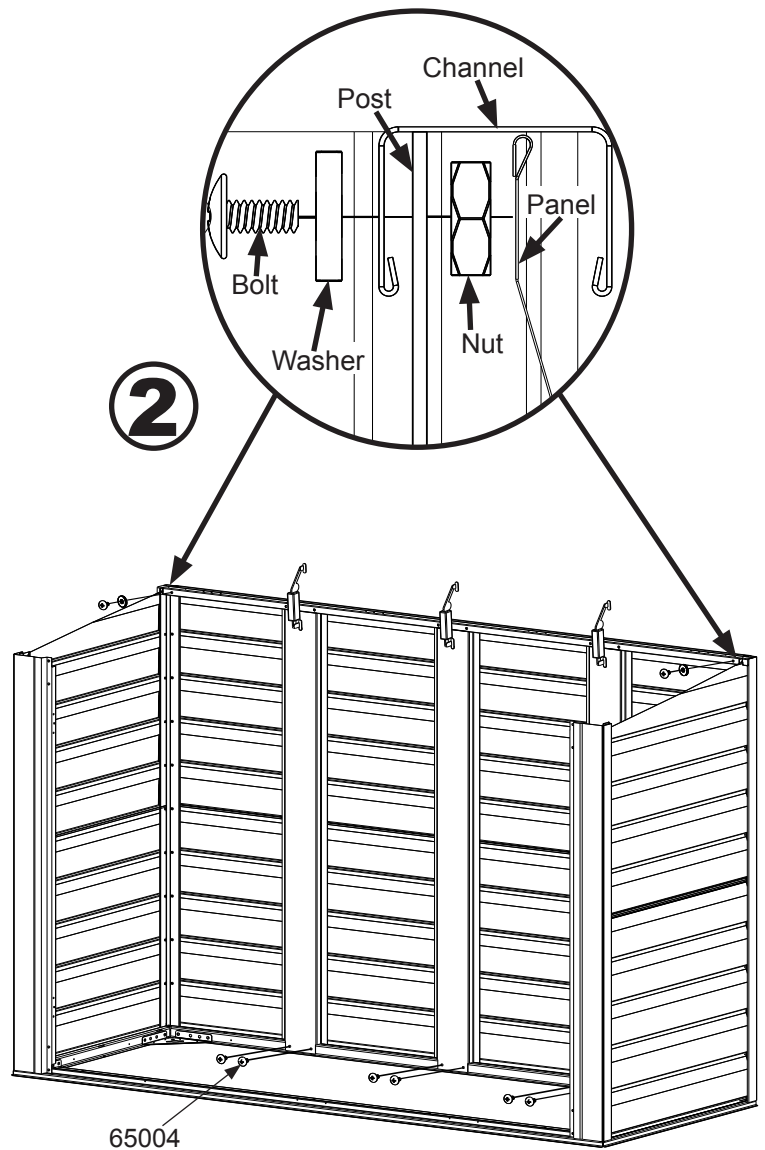
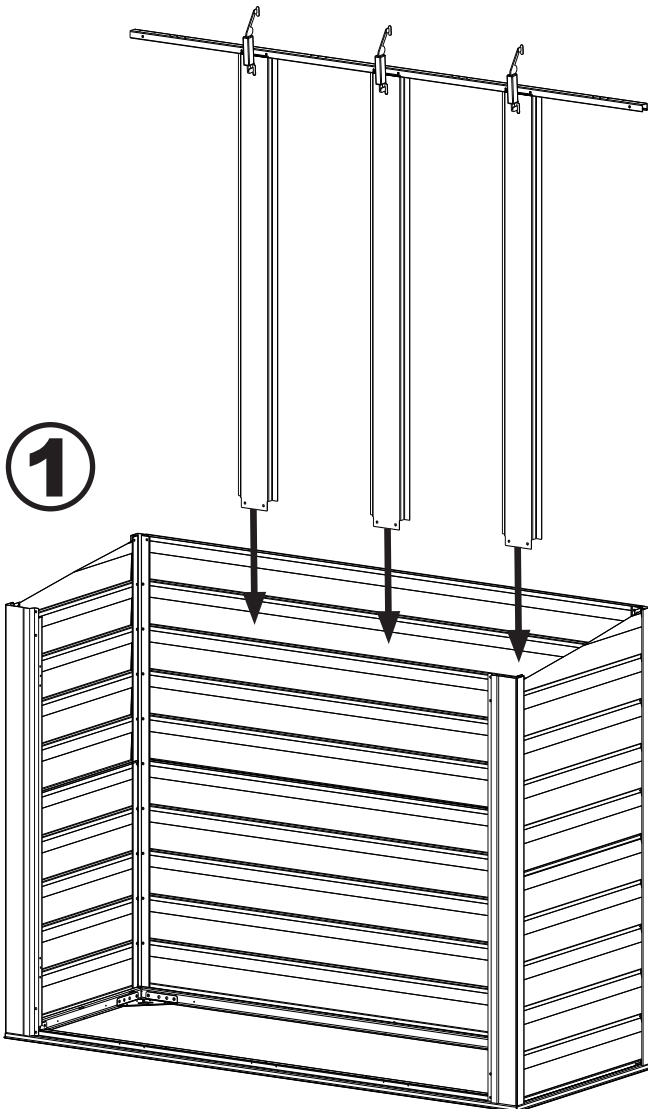

Step 11: Lintel

You will need for this page:

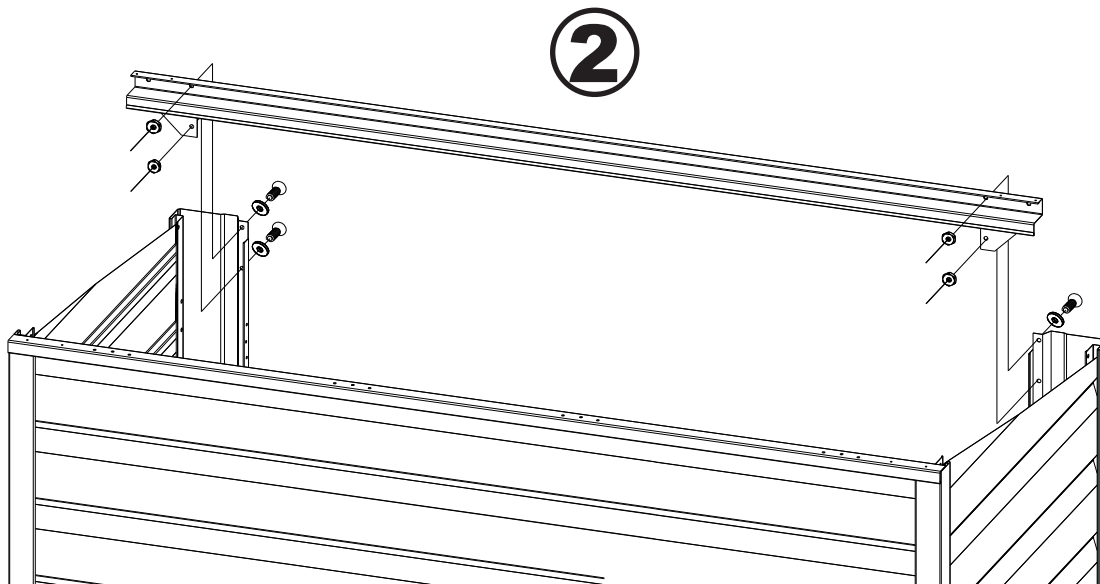
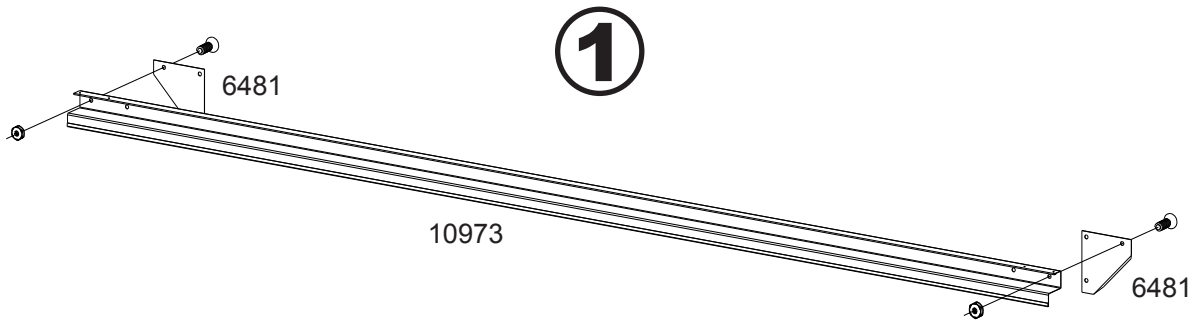
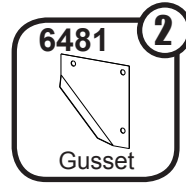
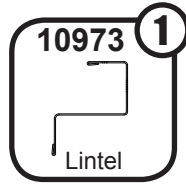
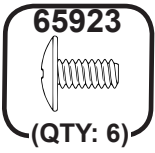

Step 12: Top Frames

You will need for this page:

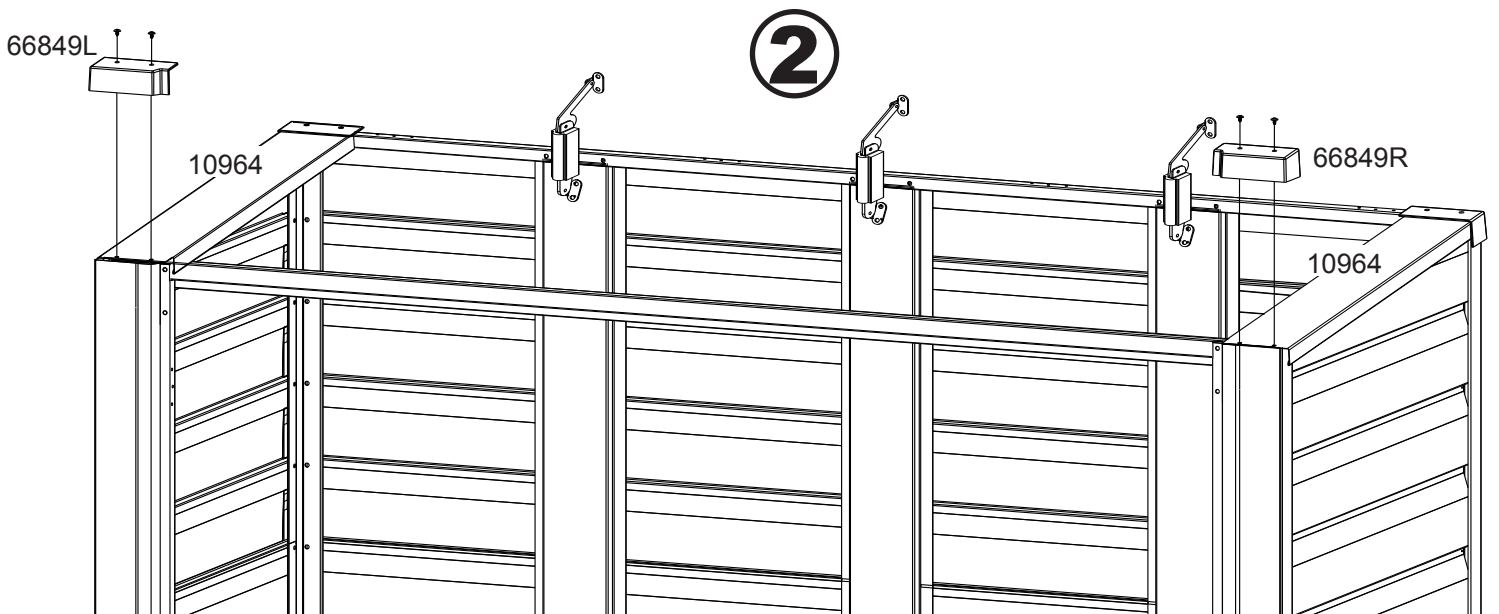
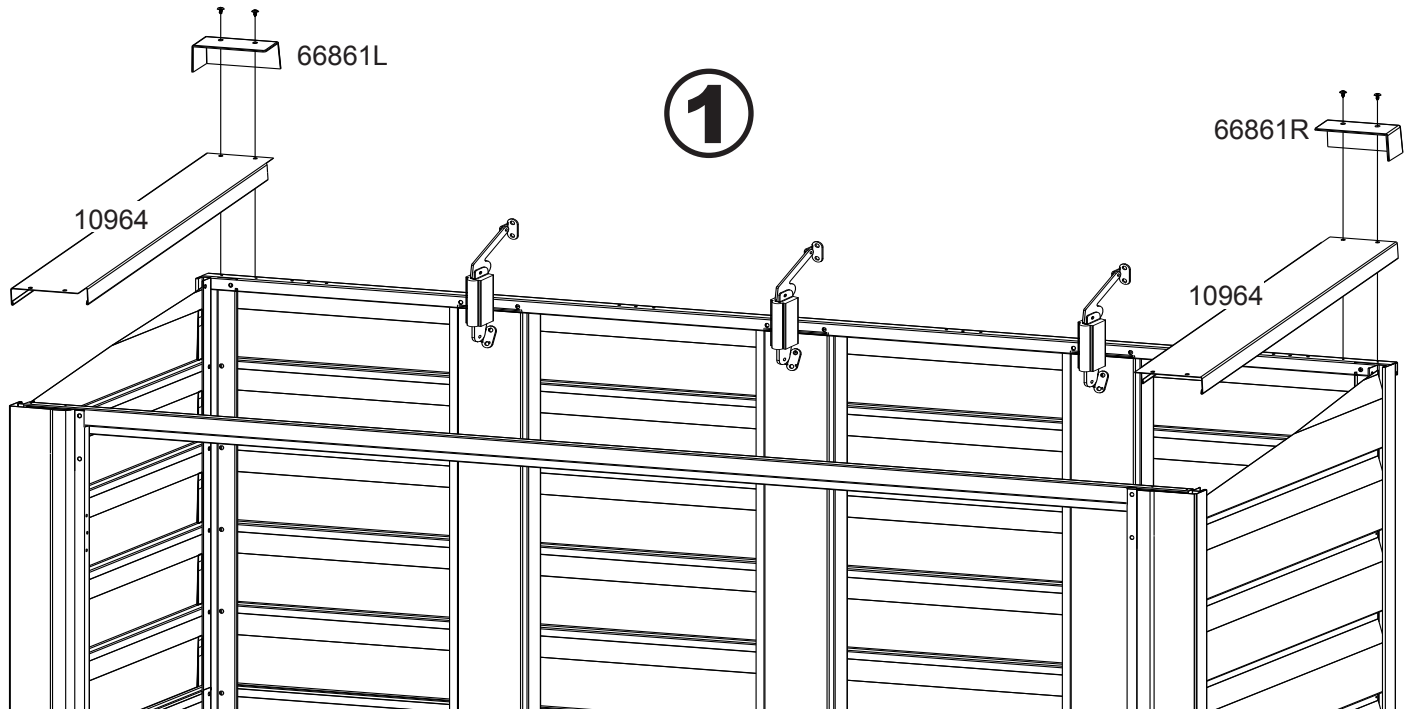
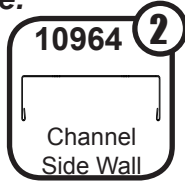

Step 13: Lid Install

You will need for this page:

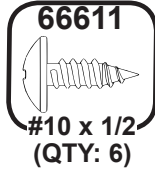
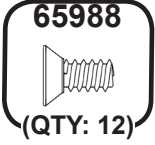

Assembly from Step 5:

- Lid Assembly

1

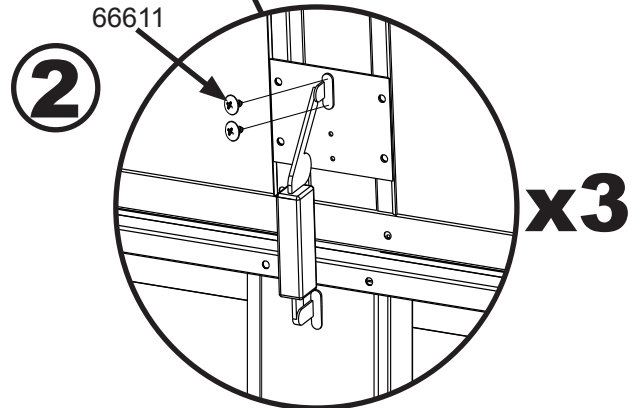
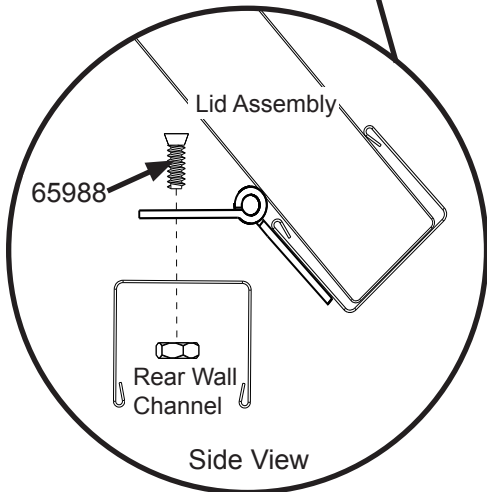
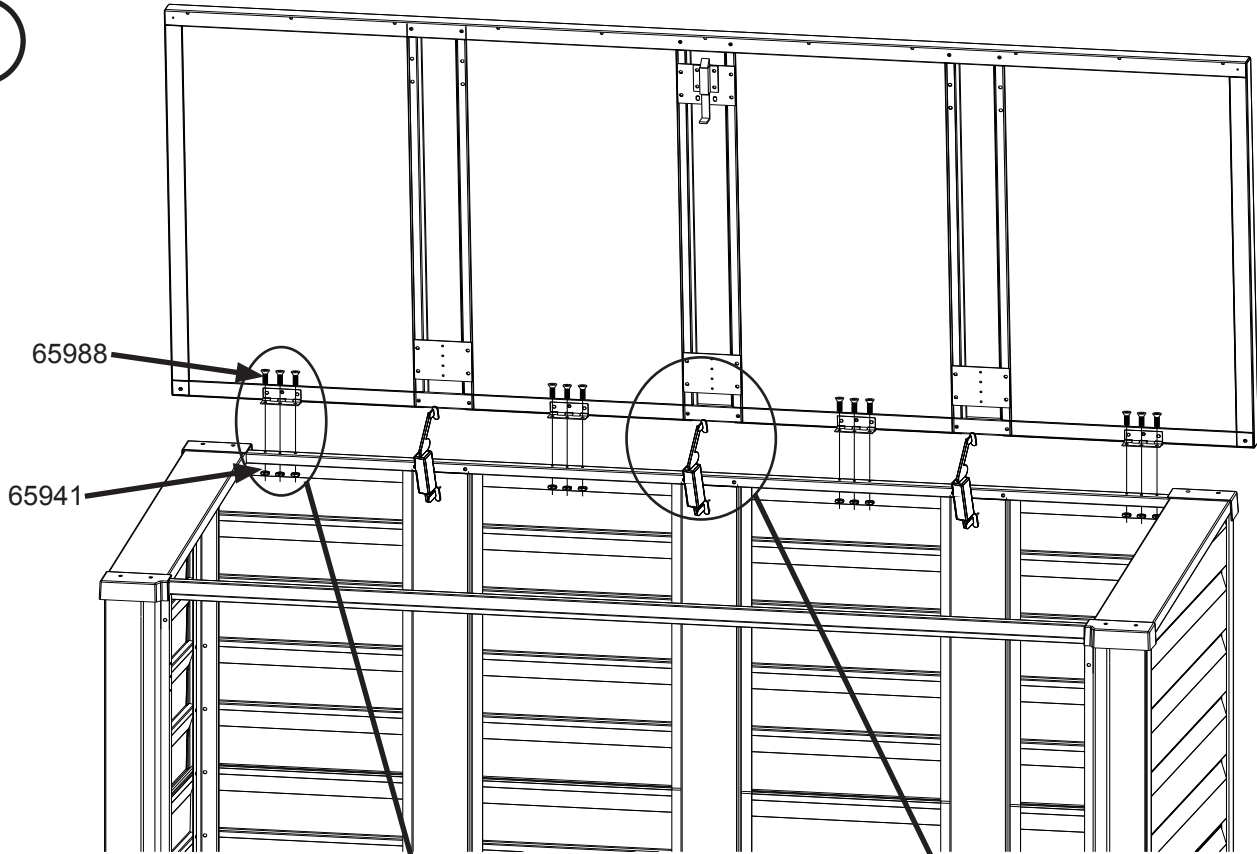

Step 14: Door Install

You will need for this page:

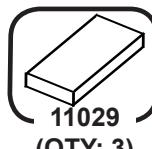
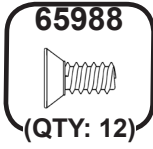

Assemblies from Step 6 and 7:

- Right and Left Door Assemblies

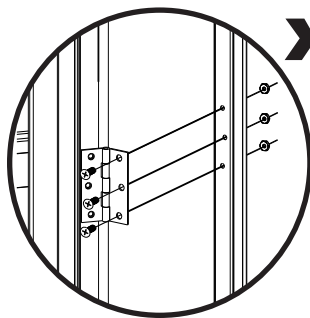

1 Left Door Assembly

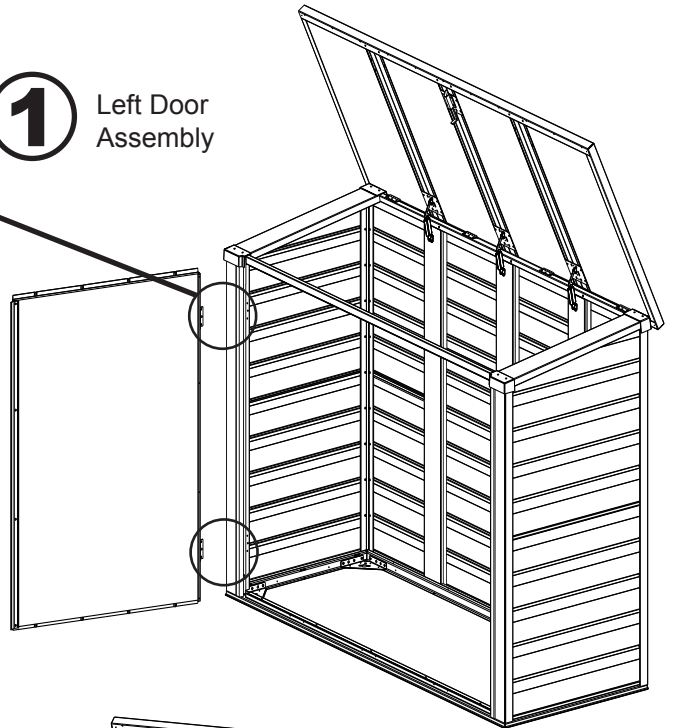

Right Door Assembly **2**

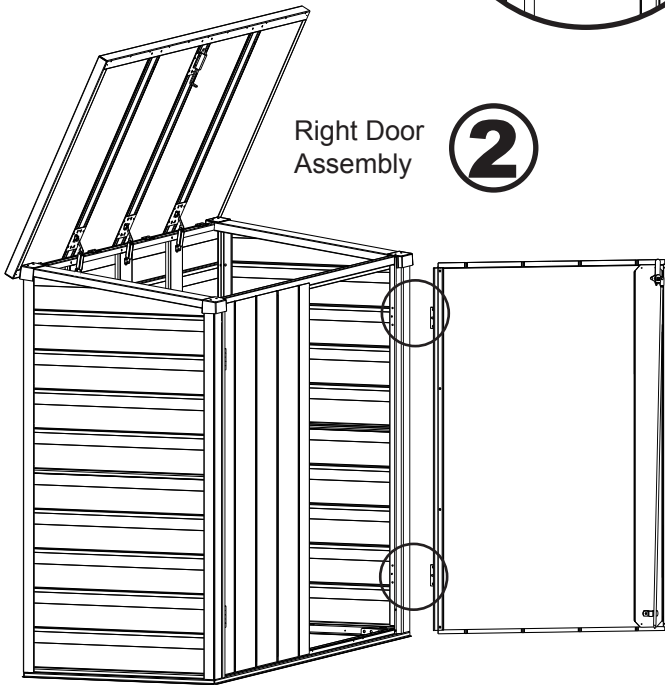

3

Adhesive Pads

11029

Right Door

Left Door

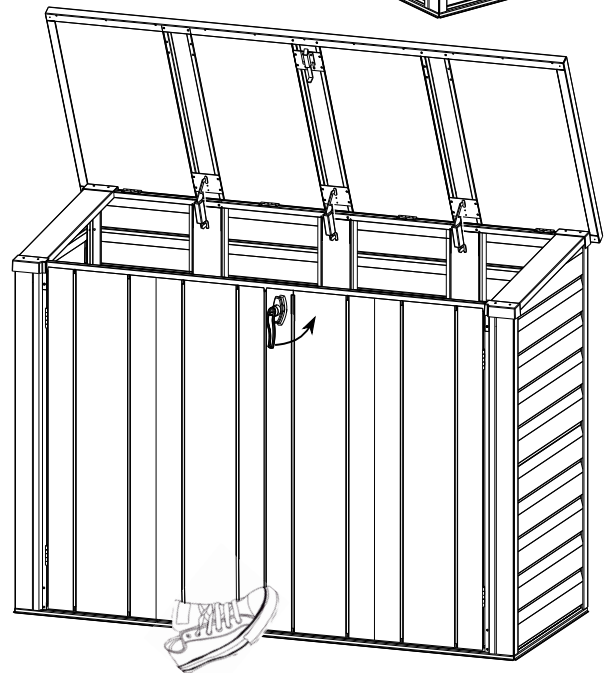
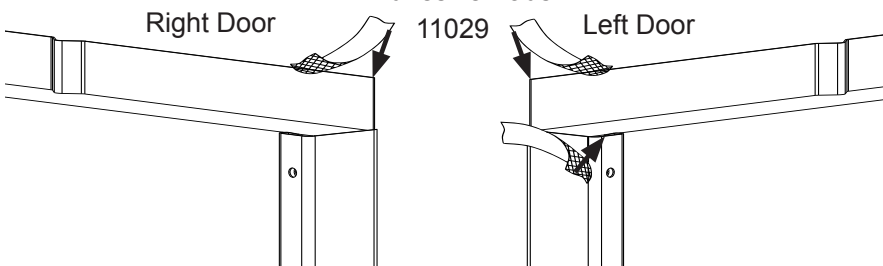

NOTE Light pressure on right door may be needed for proper closure.

ANCHORING OPTIONS...

IMPORTANT:

- *If you have swing doors, they must hang and swing level before anchoring building.*
- *Anchor your building at this time. See below for details on anchoring.*
- *If you have purchased a Floor Frame Kit, you should install it at this time.*
- *Please take a moment to ensure that the building is installed in accordance with these instructions and with all applicable regulations.*

Anchoring Down The Building

The entire floor frame **MUST** be securely anchored once the building is erected.

Below are recommended ways of anchoring.

Arrow Anchoring Kit: (Model No. AK100 or 68383)

Recommended for use with the **concrete** base.

Contains: Corner gussets, perimeter clips, hardware, 1/4" masonry drill bit and installation instructions.

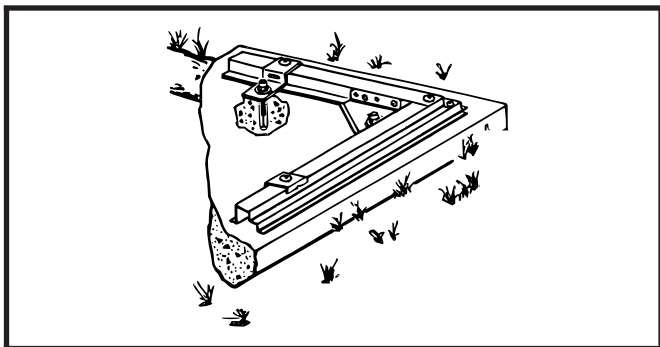

Anchoring into Concrete:

1. For poured concrete slab or footing or patio blocks: Use 1/4" x 2" (6 mm x 51 mm) Lag Screws.
2. For Anchor Post of Concrete poured after building is erected: Use 1/4" x 6" (6 mm x 152 mm) Lag Screws.

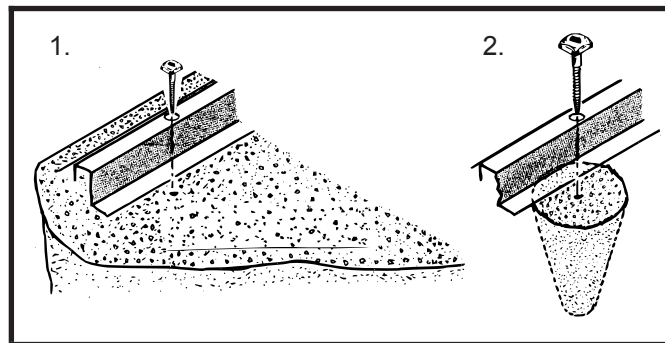

Anchoring into Wood/Post:

Use 1/4" (6 mm) Wood Screws. There are 1/4" (6 mm) dia. holes provided in the frames for proper anchoring.

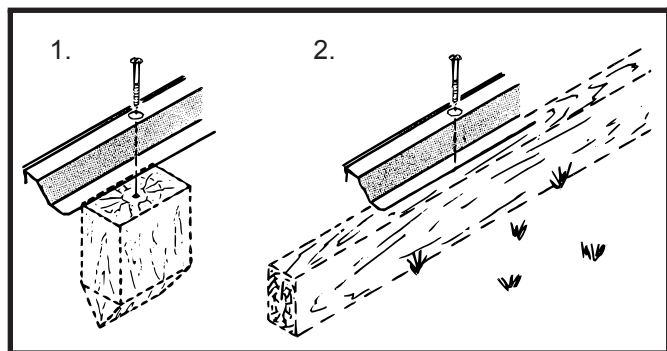

An Anchor Kit may be purchased online at www.arrowsheds.com
 You can also purchase one over the phone by calling 1-800-851-1085.
 See accessories page for details.

CARE & MAINTENANCE...

Exterior Care:

For a long lasting finish, clean and wax the exterior surface. We recommend washing with a mild soap solution. DO NOT use power washing to clean your shed. Using a spray automotive type wax periodically on the exterior is highly recommended if you are in a high humidity or coastal climate region.

Combustibles and corrosives must be stored in air tight containers designed for chemical and/or combustible storage. Corrosive chemicals such as fertilizers, pesticides and herbicides should be cleaned off the interior and exterior surfaces immediately. Rust caused by chemical damage is not covered by the warranty.

DO NOT STORE POOL CHEMICALS IN YOUR SHED - THIS VOIDS YOUR WARRANTY

Rust protection precautions may help to stop rust from developing, or stop it quickly as soon as it appears.

- Avoid nicking or scraping the coating surface, inside and out.
- Keep roof, base perimeter and door tracks free of debris and leaves which may accumulate and retain moisture. These can do double damage since they give off acid as they decay.
- Touch up scrapes or nicks and any area of visible rust as soon as possible. Make sure the surface is free of moisture, oils, dirt or grime and then apply an even film of high quality touch-up paint.
- Various paint manufacturers provide products for rust treatment and coverage. If surface rust does appear on your shed we recommend treating those areas as soon as possible, following the paint supplier of your choice instructions.
- Our customer service department can provide the paint tinting formula for matching the color of your shed. We also have touch-up paint available for repairing small nicks and scratches.

Roof:

Keep the roof clear of leaves and snow. Heavy amounts of snow on the roof can damage the building making it unsafe to enter.

General:

- A plastic sheet (vapor barrier) placed under the entire floor area may reduce condensation.
- Wash off inked part numbers on coated panels with soap and water.
- Silicone caulking may be used for watertight seals throughout the building.

Please note, Manufacturer cannot be held responsible for any consequences due to buildings that are not installed per these instructions, or for damage due to weather conditions or acts of God.

Keep these assembly instructions and owner's manual for future reference.

ASSEMBLY NOTES

ASSEMBLY NOTES

