

Owner's Manual & Assembly Instructions

CZ01

**Model No. EP64 □ PT64 □ PT64EU □
PTG64 □ PTG64EU □ EP64Z □**



Missing Parts, Questions on Assembly?

Call: 1-800-851-1085 or

assist@arrowsheds.com

Do not return to dealer, they are not equipped to handle your requests.

716730218

Storage Area: 21 Sq. Ft. 113 Cu. Ft.
2,0 m² 3,2 m³



CAUTION: SOME PARTS HAVE SHARP EDGES. CARE MUST BE TAKEN WHEN HANDLING THE VARIOUS PIECES TO AVOID A MISHAP. FOR SAFETY SAKE, PLEASE READ SAFETY INFORMATION PROVIDED IN THIS MANUAL BEFORE BEGINNING CONSTRUCTION. WEAR GLOVES WHEN HANDLING METAL PARTS.

BUILDING DIMENSIONS * Size rounded off to the nearest foot

*Approx. Size	Base Size	Exterior Dimensions (Roof Edge to Roof Edge)			Interior Dimensions (Wall to Wall)			Door Opening	
		Width	Depth	Height	Width	Depth	Height	Width	Height
6' x 4'	74" x 45 1/4"	76 1/2"	47"	67 3/4"	71 1/4"	42 1/2"	66 9/16"	32"	60"
1,8 m x 1,1 m	188,0 cm x 114,9 cm	194,3 cm	119,4 cm	172,1 cm	181,0 cm	108,0 cm	169,1 cm	81,3 cm	152,4 cm

- GB:** Assembly manual in additional languages available online.
Scan QR code below to access.
- FR:** Manuel de montage disponible en ligne dans d'autres langues.
Pour y accéder, scannez le code QR ci-dessous.
- SP:** Manual de montaje en idiomas adicionales disponible online.
Escanee el código QR a continuación para acceder.
- DE:** Montageanleitung in zusätzlichen Sprachen online verfügbar.
Scannen Sie den QR-Code unten, um darauf zuzugreifen.
- IT:** Manuale dell'assemblea in altre lingue disponibile online.
Per accedere effettua la scansione del codice QR in basso.
- PT:** Manual de montagem disponível em outros idiomas online.
Digitalize o código QR abaixo para obter acesso.
- DT:** Samlingshåndbog i yderligere sprog til rådighed online.
Scan QR kode nedenunder for at få adgang.
- SK:** Na internete je k dispozícii návod na zostavenie v ďalších jazykoch.
Dostanete sa k nemu naskenovaním kódu QR.
- CZ:** Návod k montáži v dalších jazycích je k dispozici v online verzi.
Přístup získáte po naskenování QR kódu níže.
- HU:** Az összeszerelési útmutató további nyelveken is elérhető online.
A hozzáféréshez olvassa be az alábbi QR-kódot.
- GR:** Υπάρχει διαθέσιμο στο διαδίκτυο το εγχειρίδιο συναρμολόγησης
σε περισσότερες γλώσσες. Σαρώστε τον παρακάτω κώδικα
QR για να αποκτήσετε πρόσβαση.



BEFORE YOU BEGIN...

A03

Owner's Manual

Before beginning construction, check local building codes regarding footings, location and other requirements. Study and understand this owner's manual.

Important information and helpful tips will make your construction easier and more enjoyable.

Assembly Instructions: Instructions are supplied in this manual and contain all appropriate information for your building model. Review all instructions before you begin, and during assembly, follow the step sequence carefully for successful results.

Flooring and Anchoring: Your storage building must be anchored to prevent wind damage. A base is necessary to construct a square and level building. Anchoring and base materials are not included with your building. We recommend the combined use of an Arrow Floor Frame Kit and an Arrow Anchoring Kit as an effective method of securing your building to the ground (Available at your local dealer, Arrow's website arrowsheds.com or call Arrow's Customer Service department 1-800-851-1085) or you may construct a base and anchoring system of your choice. Your assembly instructions provide information on a few methods commonly used to secure and level a storage building.

Parts and Parts List: Check to be sure that you have all the necessary parts for your building.

- All part numbers can be found on the parts. All of these numbers (before the -) must agree with the numbers on the Parts List page.

- If you find that a part is missing, include the model number of your building and contact:

Arrow Shed, LLC Customer Service Department

1101 North 4th Street Breese, Illinois 62230

1-800-851-1085 or assist@arrowsheds.com

- Separate contents of the carton by the part number while reviewing parts list. The first few steps show how to join related parts to make larger sub assemblies which will be used later.

- Familiarize yourself with the hardware and fasteners for easier use during construction. These are packaged within the carton. Note that extra fasteners have been supplied for your convenience.

PLAN AHEAD....

A04

Watch the Weather: Be sure the day you select to install your building is dry and calm. Do not attempt to assemble your building on a windy day. Be careful on wet or muddy ground.

Teamwork: Whenever possible, two or more people should work together to assemble your building. One person can position parts or panels while the other is able to handle the fasteners and the tools.

Tools and Materials: These are some basic tools and materials you will need for the construction of your building. Decide which method of anchoring and the type of base you wish to use in order to form a complete list of the materials you will need.

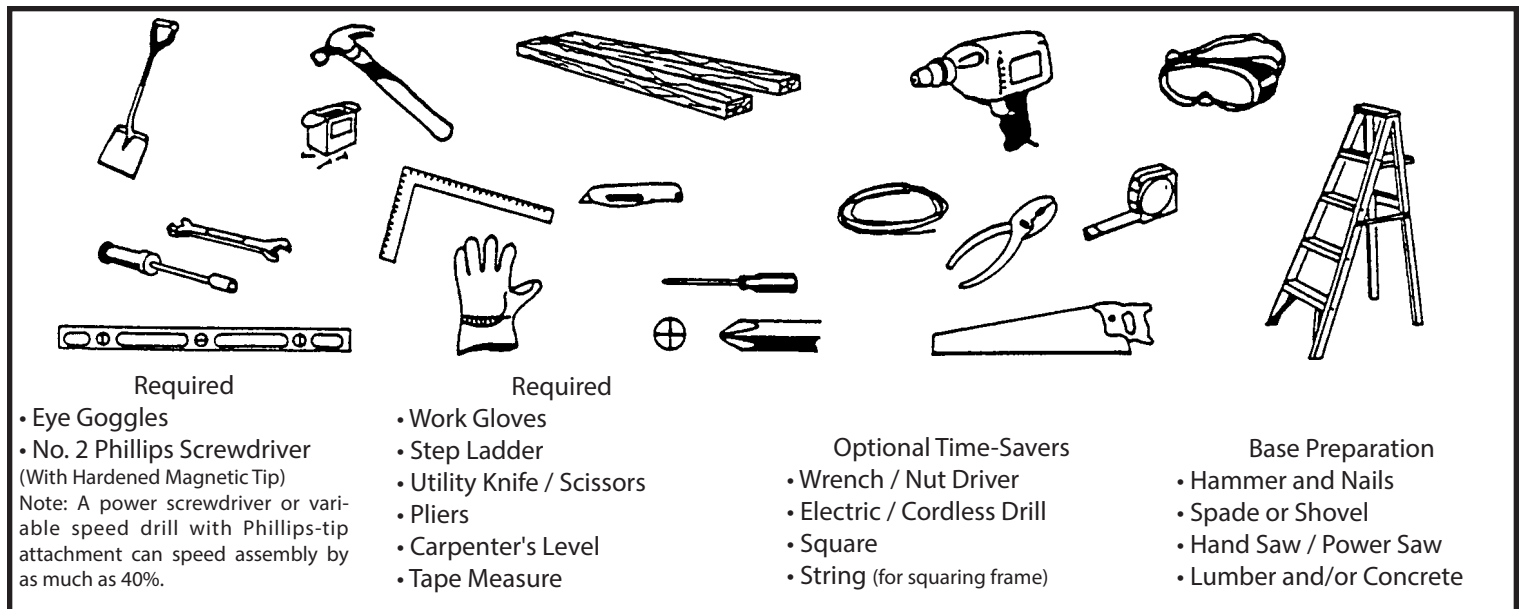

Selecting and Preparing Your Site: Before assembly, you will want to decide on a location for your building. The best location is a level area with good drainage.

- Allow enough working space for ease of moving parts into position during assembly. Be sure there will be enough space at entrance for doors to open fully and enough space around the building to be able to fasten the panel screws from the outside.

- Before you begin the first steps in assembling your parts, a base should be constructed and an anchoring system should be ready to use.

SAFETY FIRST...

Safety precautions are important to follow throughout the construction of your building.

•Care must be taken when handling various pieces of your building since some contain sharp edges. Please wear work gloves, eye protection and long sleeves when assembling or performing any maintenance on your building.

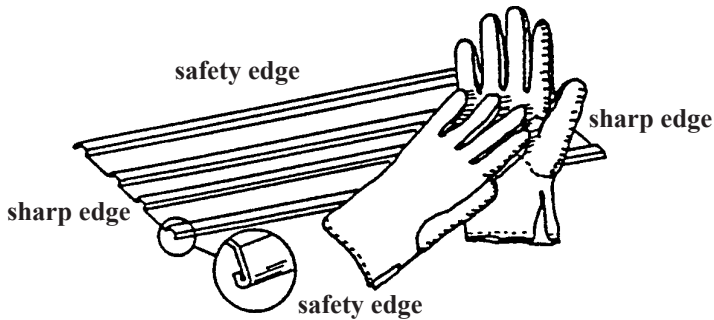

•Keep children and pets away from worksite to avoid distractions and any accidents which may occur.



•Never concentrate your total weight on the roof of the building. When using a step ladder make sure that it is fully open and on even ground before climbing on it.

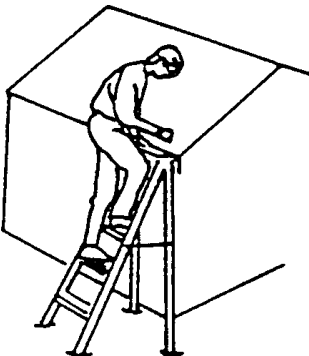

•Practice caution with the tools being used in the assembly of this building. Be familiar with the operation of all power tools.



•Do not attempt to assemble the building if parts are missing because any building left partially assembled may be seriously damaged by light winds. Call 1-800-851-1085 or assist@arrowsheds.com

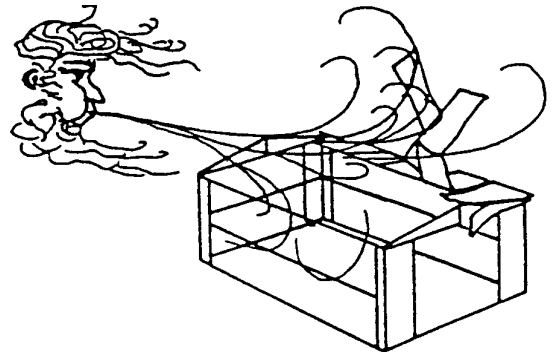

•Do not attempt to assemble the building on a windy day, because the large panels acting as a "sail", can be whipped about by the wind making construction difficult and unsafe.



CARE & MAINTENANCE....

A06

Finish: For long lasting finish, periodically clean and wax the exterior surface. Touch-up scratches as soon as you notice them on your unit. Immediately clean the area with a wire brush; wash it and apply touch-up paint per manufacturer's recommendation.

Roof: Keep roof clear of leaves and snow with long handled, soft-bristled broom. Heavy amounts of snow on roof can damage building making it unsafe to enter. In snow country, Roof Strengthening Kits are available for most Arrow Buildings for added protection against heavy snow accumulation. Contact Arrow as outlined on the Ordering Accessories page to place an order.

Doors: Always keep the door tracks clear of dirt and other debris that prevent them from sliding easily. Lubricate door track annually with furniture polish or silicone spray. Keep doors closed and locked to prevent wind damage.

Fasteners: Use all washers supplied to protect against weather infiltration and to protect the metal from being scratched by screws. Regularly check your building for loose screws, bolts, nuts, etc. and retighten them as necessary.

Moisture: A plastic sheet (vapor barrier) placed under the entire floor area with good ventilation will reduce condensation.

Other Tips....

- Wash off inked part numbers on coated panels with soap and water.
- Silicone caulking may be used for watertight seals throughout the building.

Do not store swimming pool chemicals in your building. Combustibles and corrosives must be stored in air tight approved containers.

Keep this Owner's Manual and Assembly Instructions for future reference.

ACCESSORIES...

A07

ROOF STRENGTHENING (heavy snow load) KITS

Extra roof beams and gable braces designed for added protection against heavy snow accumulation. Increases the strength of your roof.

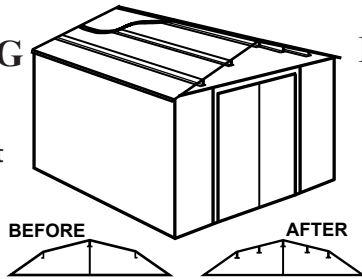

ANCHOR KITS

Model No. AK4

Anchor Kit contains heavy-duty steel augers, 60' (18 m) of steel cable and 4 cable clamps. No digging or concrete pouring, just insert cable under roof, over roof beams, into augers and twist augers into the ground. For buildings larger than 10'x9' (3,0 m x 2,6 m), use 2 kits.

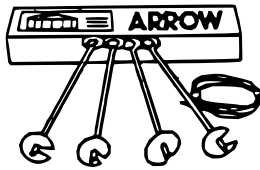

Model No. AK100

New concrete anchor system permits anchoring any size Arrow building directly to a concrete slab. Each kit contains heavy-duty, hot-dipped galvanized steel corner gussets and perimeter clips which fit over the floor frame and lag bolt into a concrete slab. Full assembly instructions and a 1/4" masonry drill bit are included.

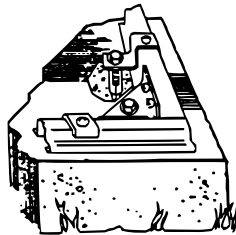

Model No. AK600

Earth Anchor Kit anchors any size Arrow building to the ground. Each kit contains heavy duty, hot-dipped galvanized steel corner gussets and 4 earth anchors.

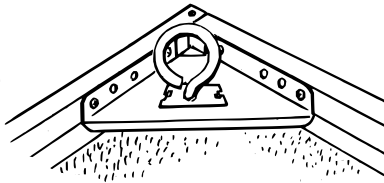

TOOL HANGING RACK

Model No. TH100

The perfect tool organizer. Twin 25 1/2" (64,8 cm) steel channels plus five heavy-duty snap-in hangers and a small tool holder for screwdrivers, pliers, etc. Holders slide along channel for fully adjustable spacing. Great for garage, basement, or the back of any door. Fits all Arrow storage buildings.

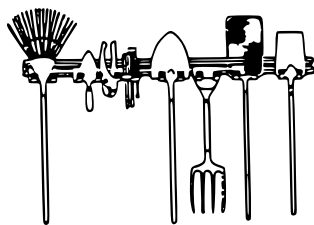

FLOOR FRAME KITS

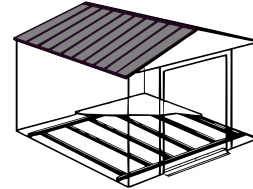

MODELS FB47410, FB5465, FB106-A
FB109-A and FB1014-A

A simple new floor frame system made of heavy-duty, hot-dipped galvanized steel. Use as base for plywood, sand or stone.

ATTIC KIT / WORKBENCH KIT

Model No. AT101

Heavy-duty galvanized steel bars that fit all 10' (3,0 m) wide Arrow buildings. They install quickly and easily to help organize space and create more useable space as an attic or workbench. Will hold up to 250 lbs. (113 kg) evenly distributed.

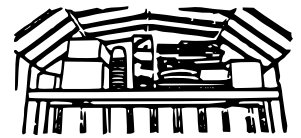

Some drilling required to fit buildings without mid-wall bracing.

SHELF UNITS

Heavy-duty, galvanized steel shelf units help organize storage space. They easily mount on the wall or sit on the floor. Fits all Arrow buildings.*

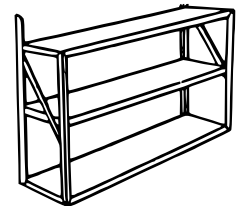
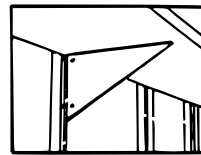
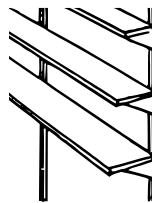

Model No. SS404

- Makes 8" to 12" (20,3-30,5 cm) wide shelves in any length.
- Brackets, braces, hardware included.
- Lumber is not included.

Model No. SS900-B

- Grey color
- 3 shelves
- Holds up to 85 lbs. (38 kg) (even weight distribution)

* Some drilling required to fit buildings without mid-wall bracing.

ORDERING ACCESSORIES....

A08

02/13

We recommend that you purchase accessory items from your local storage building dealer whenever possible; however, because the full line of accessories is not always available from all dealers, Arrow is offering them to you on a direct basis.

There are two ways to order Arrow Storage Building Accessories:

Option 1	Option 2
<p data-bbox="212 720 607 789">Accessories can be purchased through</p> <p data-bbox="302 835 518 863">arrowsheds.com</p>	<p data-bbox="881 724 1427 793">Order accessories by telephone using your MasterCard or Visa credit card.</p> <p data-bbox="967 840 1341 909">Call toll free 1-800-851-1085 (Customer Service).</p> <p data-bbox="979 955 1330 982">Allow 2 weeks for delivery.</p>

SPECIAL NOTE:

If your accessory is shipped via truck line a day time phone number is required to arrange delivery. If no one is available to sign for the delivery, you may be subject to a re-delivery charge assessed by the carrier.

Base

YV09

The Base For Your Building

OPTION 1: Wood Platform

If you decide to build your own base, be sure to select the appropriate materials.

These are the recommended materials for your base:

2 x 4's (38 mm x 89 mm) Pressure Treated Lumber

5/8" (15,5 mm) 4 x 8 (1220 mm x 2440 mm) Plywood-exterior grade NOTE: Pressure Treated Lumber must not be used where it will make contact with your storage building. The properties of Pressure Treated Lumber will cause accelerated corrosion.

If Pressure Treated Lumber comes in contact with your storage building your warranty will be voided.

10 & 4 penny Galvanized Nails Concrete Blocks (optional)

The platform should be level and flat (free of bumps, ridges etc.) to provide good support for the building. The necessary materials may be obtained from your local lumber yard.

To construct the base follow instructions and diagram.

Construct frame (using 10 penny galvanized nails)

Measure 16"/24" (40,6 cm/61,0 cm) sections to construct inside frame (see diagram)

Secure plywood to frame (using 4 penny galvanized nails)

Allow 6 - 7 hours for construction.

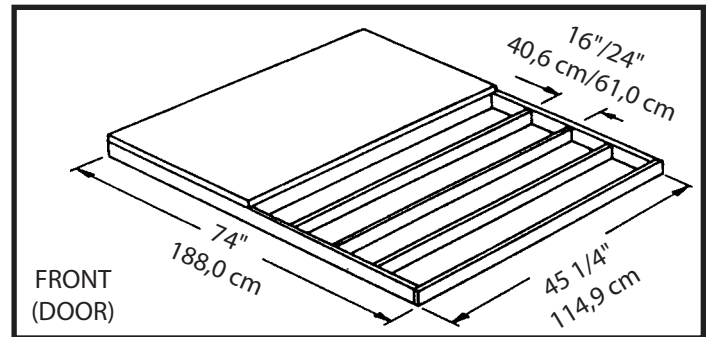

Note: Platform/Slab will extend 9/16" (1,4 cm) beyond floor frame on all four sides. Seal this 9/16" (1,4 cm) of wood with a roofing cement (not included), or bevel this 9/16" (1,4 cm) of concrete when pouring, for good water drainage.

OPTION 2: Concrete Slab

The slab should be at least 4" (10,2 cm) thick. It must be level and flat to provide good support for the frame.

The following are the recommended materials for your base.

1 x 4's (19 mm x 89 mm) (will be removed once the concrete cures)

Concrete Sheet of 6 mil plastic

We recommend for a proper strength concrete to use a mix of:

1 part cement 3 parts pea sized gravel 2 1/2 parts clean sand

Prepare the Site/Construct a Base

1. Dig a square, 6" (15,2 cm) deep into the ground (remove grass).
2. Fill up to 4" (10,2 cm) in the square with gravel and tamp firm.
3. Cover gravel with a sheet of 6 mil plastic.
4. Construct a wood frame using four planks of 1x4 (19 mm x 89 mm) lumber.
5. Pour in concrete to fill in the hole and the frame giving a total of 4" (10,2 cm) thick concrete. Be sure surface is level.

Allow 3 - 5 hours for construction and a week for concrete curing time.

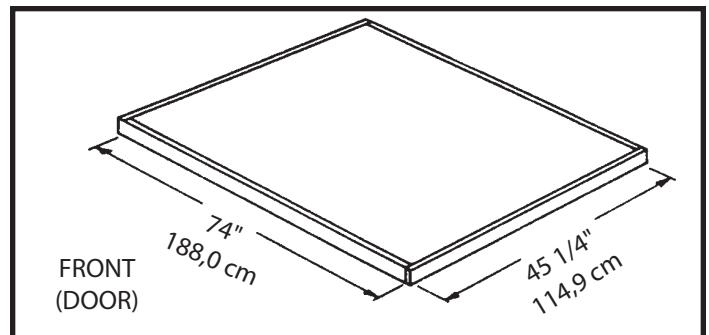

Note: Finished Slab dimensions, with lumber removed.

Anchoring

A10

Anchoring Down The Building

It is important that the entire floor frame be anchored after the building is erected.

Below are recommended ways of anchoring.

Arrow Anchoring Kit: (Model No. AK4 or 60298)

Recommended for use with any suggested base.

Contains: 4 Anchors with Cable, Clamps and installation instruction.

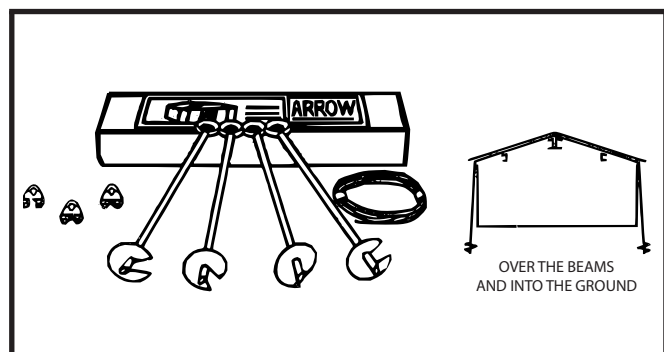

Anchoring into Wood/Post:

Use 1/4" (6 mm) Wood Screws. There are 1/4" (6 mm) dia. holes provided in the frames for proper anchoring.

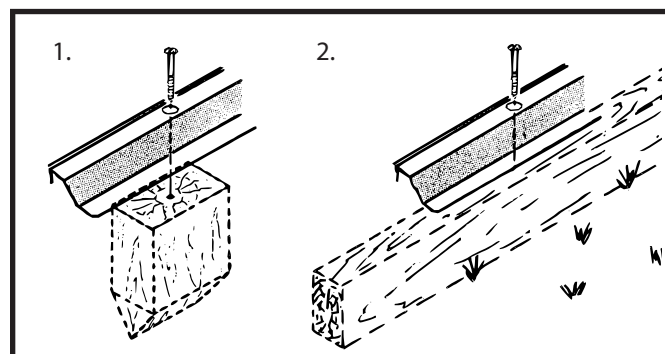

Arrow Anchoring Kit: (Model No. AK100 or 68383)

Recommended for use with the concrete base.

Contains: Corner gussets, perimeter clips, hardware, 1/4" masonry drill bit and installation instruction.

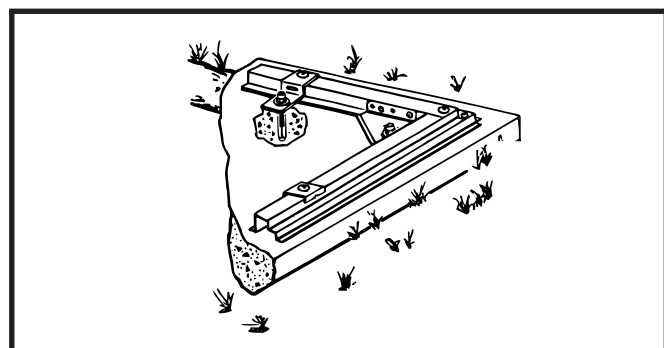

Anchoring into Concrete:

1. For poured concrete slab or footing or patio blocks:

Use 1/4" x 2" (6 mm x 51 mm) Lag Screws.

2. For Anchor Post of Concrete poured after building is erected: Use 1/4" x 6" (6 mm x 152 mm) Lag Screws.

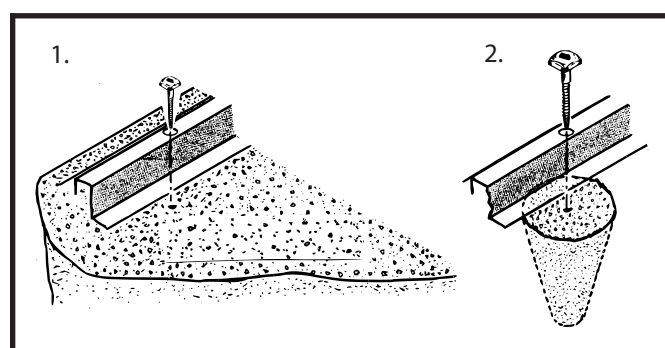

Hardware

VVII

Remove from bag of screws
and save for the last step



65103
#8-32 Hex Nut (37)



65900A
#10Bx1/2" (13 mm)
Black Screw (8)
(Packed with Screws)



65923
#8-32x3/8" (10 mm)
Bolt (37)



65004
#8Ax5/16" (8 mm)
Screw (168)

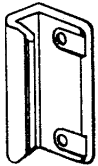

66045
Handle (2)

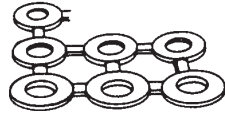

66646
Washer (179)
(5 sheets of 40)



65109
#8-32 Acorn Nut (6)
(Packed with Screws)



66775
Plug (2)
(Packed with Screws)

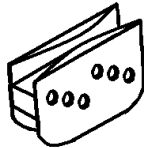

66769
Door Slide (4)

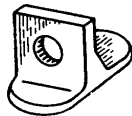

66382
Lower Door Guide (4)

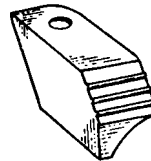

66183
Roof Trim Cap
(2 right & 2 left)

Parts List

YV12

Assembly Key No.	Part Number	Part Description	Quantity in Carton	Check List
1	10569	Roof Beam	1	
2	10564	Side Wall Angle	2	
3	10562	Right Gable	1	
4	80015	Left Gable	1	
5	80002	Roof Trim	2	
6	10558	Right Roof Panel	1	
7	80011	Left Roof Panel	1	
8	10499	Horizontal Door Brace	4	
9	6657	Door Handle Brace	2	
10	6515	Wall Panel (Rear)	2	
11	10476	Right and Left Doors	2	
12	10563	Wall Panel (Side)	2	
13	9369	Door Jamb	2	
14	9389	Front Corner Panel	2	
15	10561	Rear Corner Panel	2	
16	9396	Door Track	1	
17	10565	Rear Wall Angle	1	
18	9925	Rear Wall Channel	1	
19	9399	Rear Floor Frame	1	
20	10545	Side Wall Channel	2	
21	10544	Side Floor Frame	2	
22	9403	Front Floor Frame	1	
23	10557	Roof Panel	1	
24	10572	Front Header	1	

Assembly by Key No.

YV13

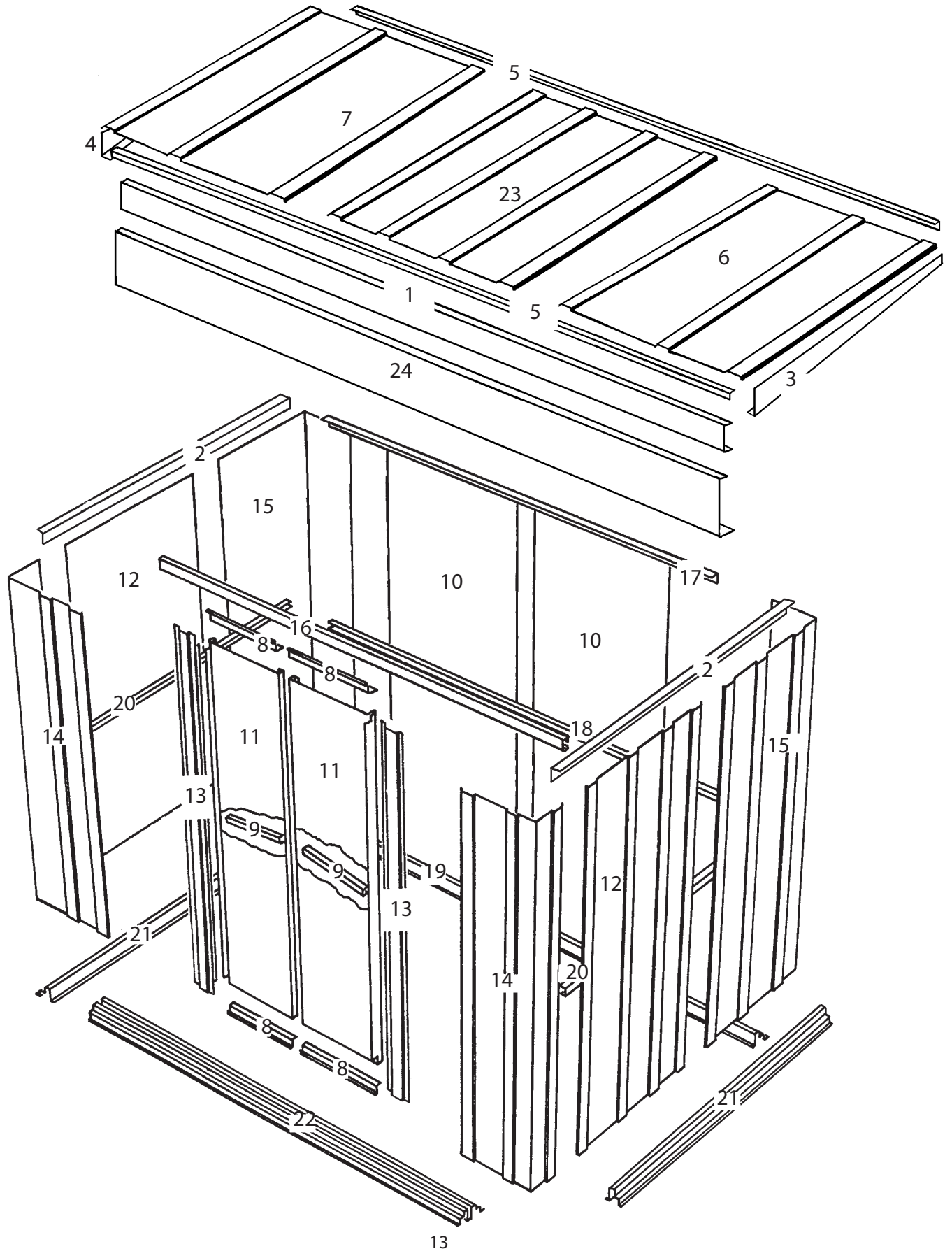

Step 1

Parts Needed For Door Track/Header Assembly

9396 Door Track (1)
10572 Header (1)

YV14

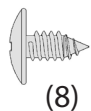

The door track/header assembly supports the sliding doors and reinforces the front wall. It is made up of two pieces.

1 Using the door track, with small holes on top, join the header, short leg on top, as shown using screws.

2 Position door slides onto the legs, from the end of door track, as shown in the end view.

3 Set this piece aside for later use.

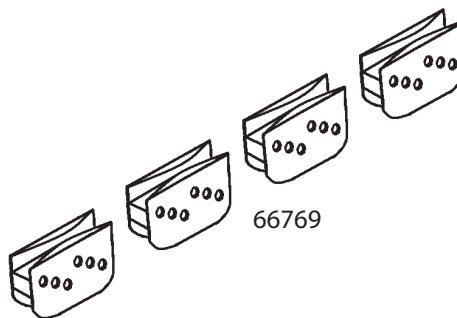

STEP
1

10572

Long Leg
on Top

Short Leg
on Bottom

9396



END VIEW



STEP
2

Step 2

YV15

Parts Needed For Floor Frame

9403 Front Floor Frame (1)
9399 Rear Floor Frame (1)
10544 Side Floor Frame (2)

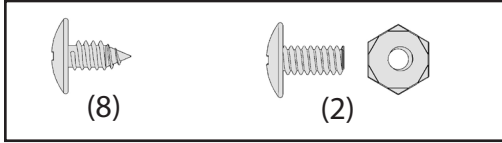

1 Assemble the four corners of the floor frame using two screws at each corner as shown. At the front corners fasten bolts through from the bottom with nuts on top.

STEP
1

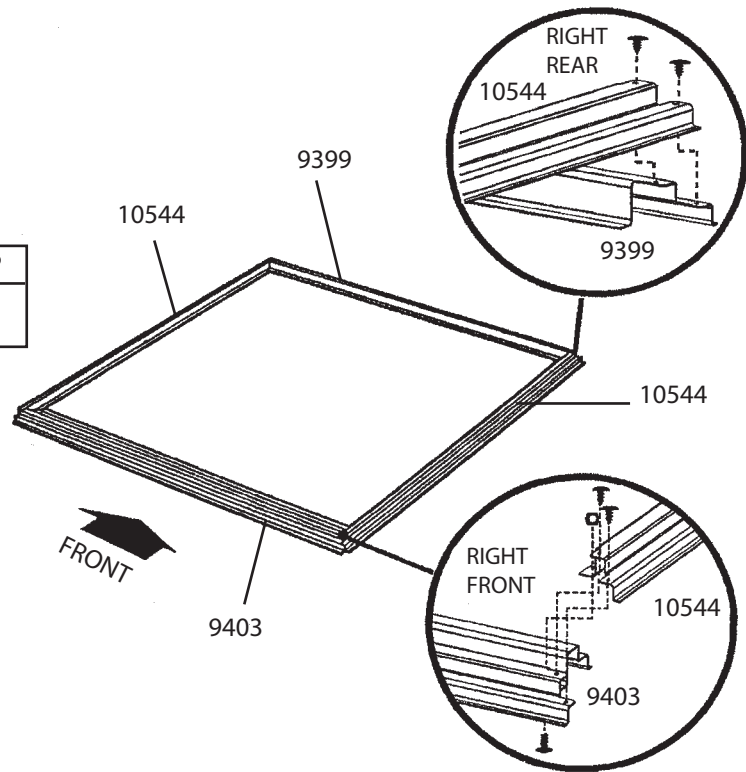

2 Measure the floor frame diagonally. When the diagonal measurements are equal, the floor frame is square.

NOTE

If using a wood platform or concrete slab do not fasten the floor frames to your base at this time. You will anchor the building after it is erected.

When Diagonal Measurements are Equal the Floor Frame is Square

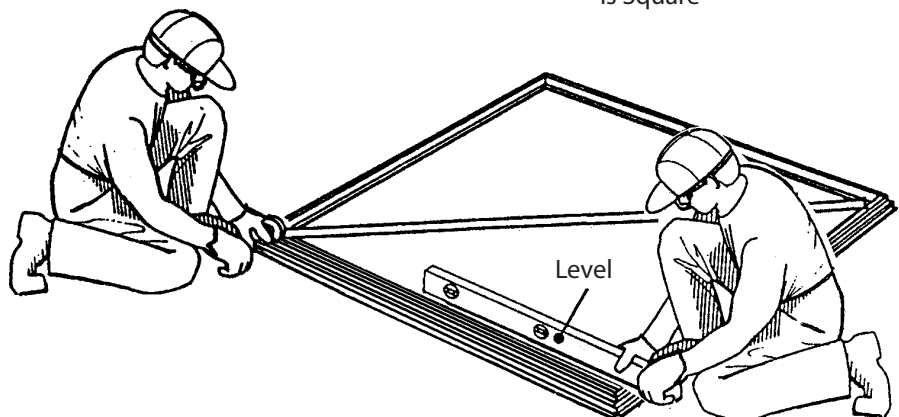

The floor frame must be square and level or holes will not align.

Step 3

YV16

Parts Needed For Corners/Wall Panels

9389 Front Corner Panel (2)
10561 Rear Corner Panel (2)
10563 Wall Panel (2)

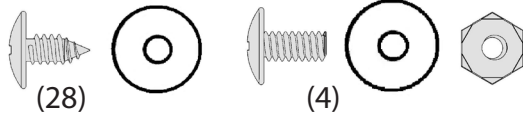

NOTE

The remainder of the building assembly requires many hours and more than one person. Do not continue beyond this point if you do not have enough time to complete the assembly today. A partially assembled building can be severely damaged by light winds.

Each screw and bolt in the wall requires a washer.



CORRECT



INCORRECT

1 Position rear corner panels at the rear corners as shown. The widest part of each corner panel must be placed along side of the building. Fasten corner panels to the floor frame using four screws.

2 Position front corner panels at the corners of the floor frame as shown. The widest part of each corner panel must be placed along the front of the building. Fasten the corner panels to the floor frame with two screws.

NOTE

The wall panels come in two widths. Each wall panel has a crimped rib on one side. The crimped rib should go under the rib of the panel that follows it.

3 Attach wall panels to the sides, as shown.

NOTE

Be careful to install the correct panel in each position as shown.

4 Double-check the part numbers of the wall panels, before proceeding.

STEP
1

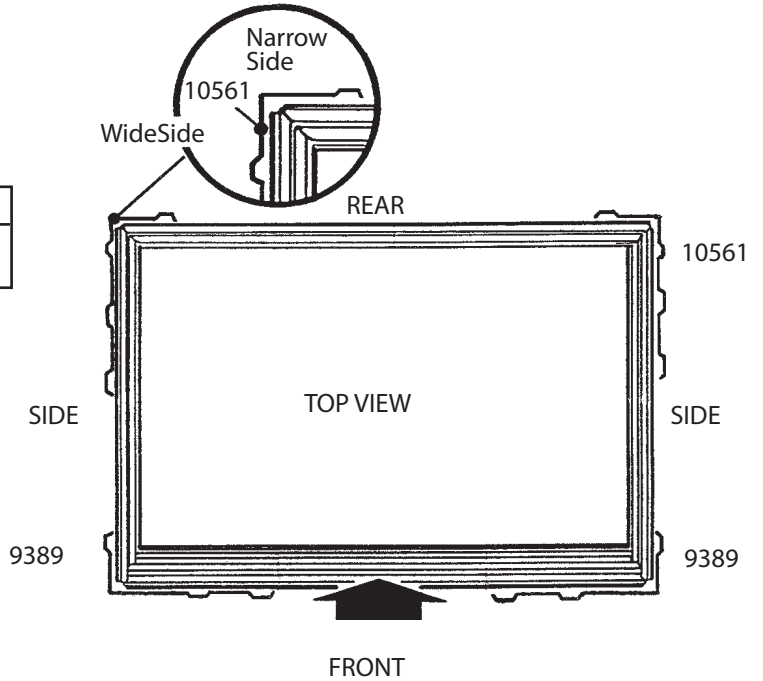

STEP
2

SUPPORT THE CORNER PANEL WITH A STEP LADDER UNTIL A WALL PANEL IS ATTACHED.

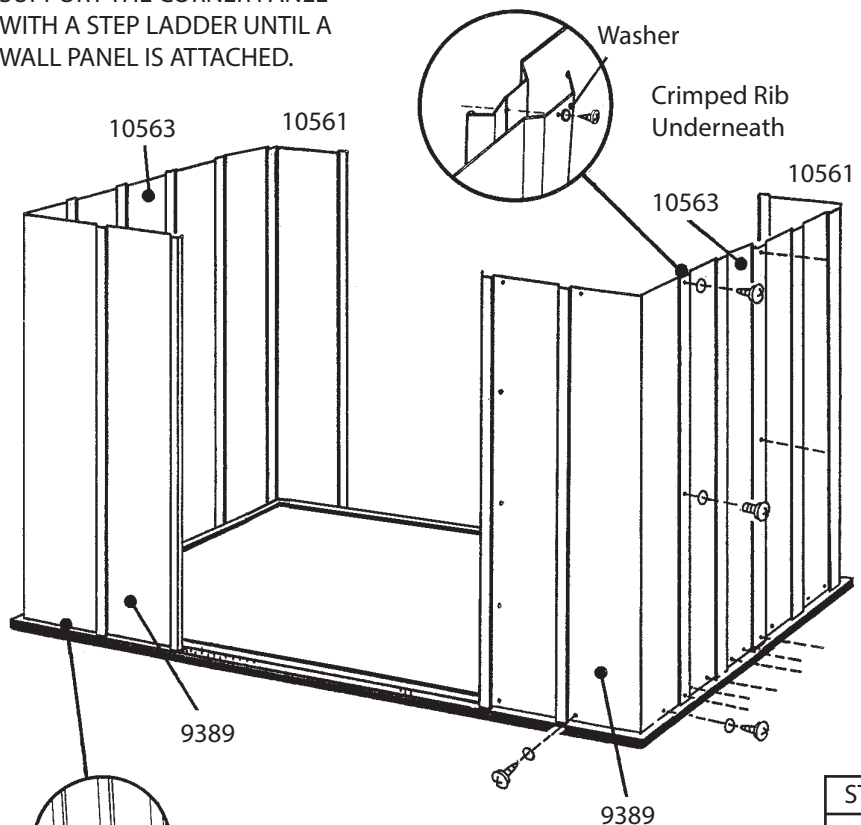

STEP
3

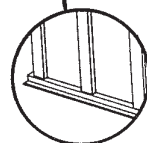

Panels rest on frame as shown

The floor frame must be square and level or holes will not align.

Step 4

YV17

Parts Needed For Frames

10565 Rear Wall Angle (1)
9925 Rear Wall Channel (1)
10545 Side Wall Channel (2)
10564 Side Wall Angle (2)
Door Track/Header Assembly (1)

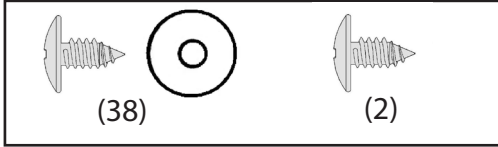

The main frame pieces give rigidity to the side walls and provide a surface for attaching the gables which support the roof.

1 Fasten the rear wall angle across the inside top of the rear wall using screws.

2 Fasten the rear wall channel across the middle of the rear wall using screws.

NOTE
The upper leg of the side wall angles must face the outside of the building.

3 Fasten the side wall angles across the inside top of the side panels using screws.

4 Fasten the side wall channels across the middle of the side panels using screws. Fasten overlaps in rear corners with screws.

5 Fasten the door track/header assembly across the top of the front wall panels using screws. See the figure.

STEP
3

Side Wall Angles
Must Face
Outside Building

Gap
13/16"
(2,1 cm)

Rear Wall
Angle Must
Face Inside
Building

STEP
1

10565

STEP
2

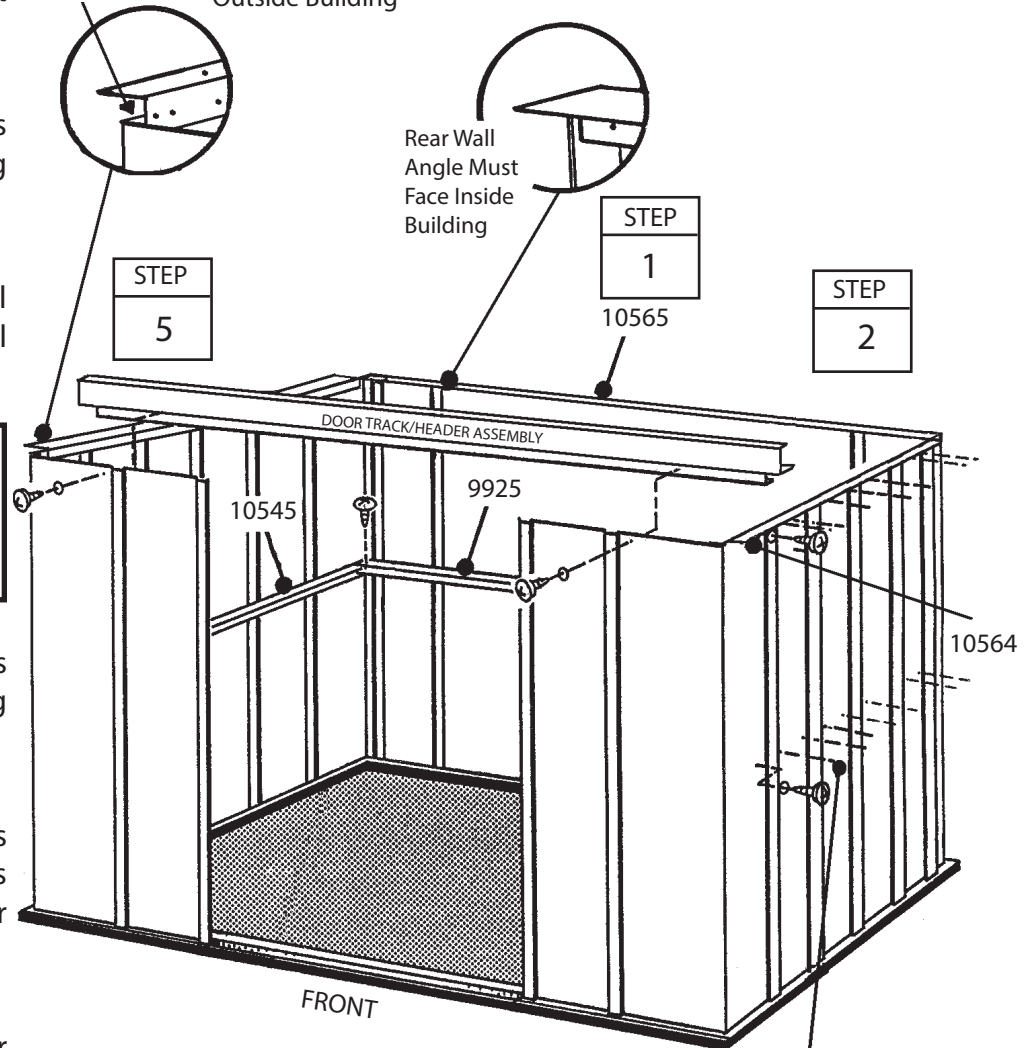

Detail Showing
Center of Panel
Screwed
to Wall Channel

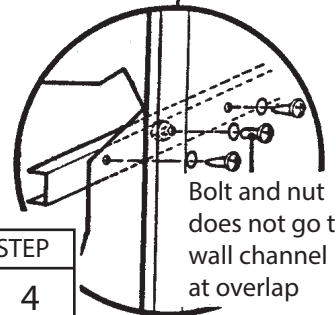

Bolt and nut
does not go thru
wall channel
at overlap

STEP
4

Step 5

Parts Needed For Wall Panels

6515 Wall Panel (2)

YV18

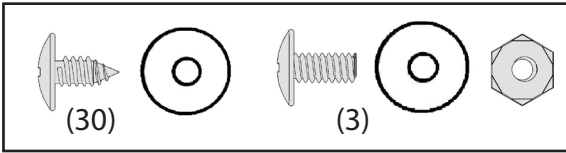

1 Fasten the wall panels at the top and bottom with screws.

2 Fasten the center of each panel to the wall channel with screws. Fasten overlapping ribs as before.

STEP	STEP
1	2

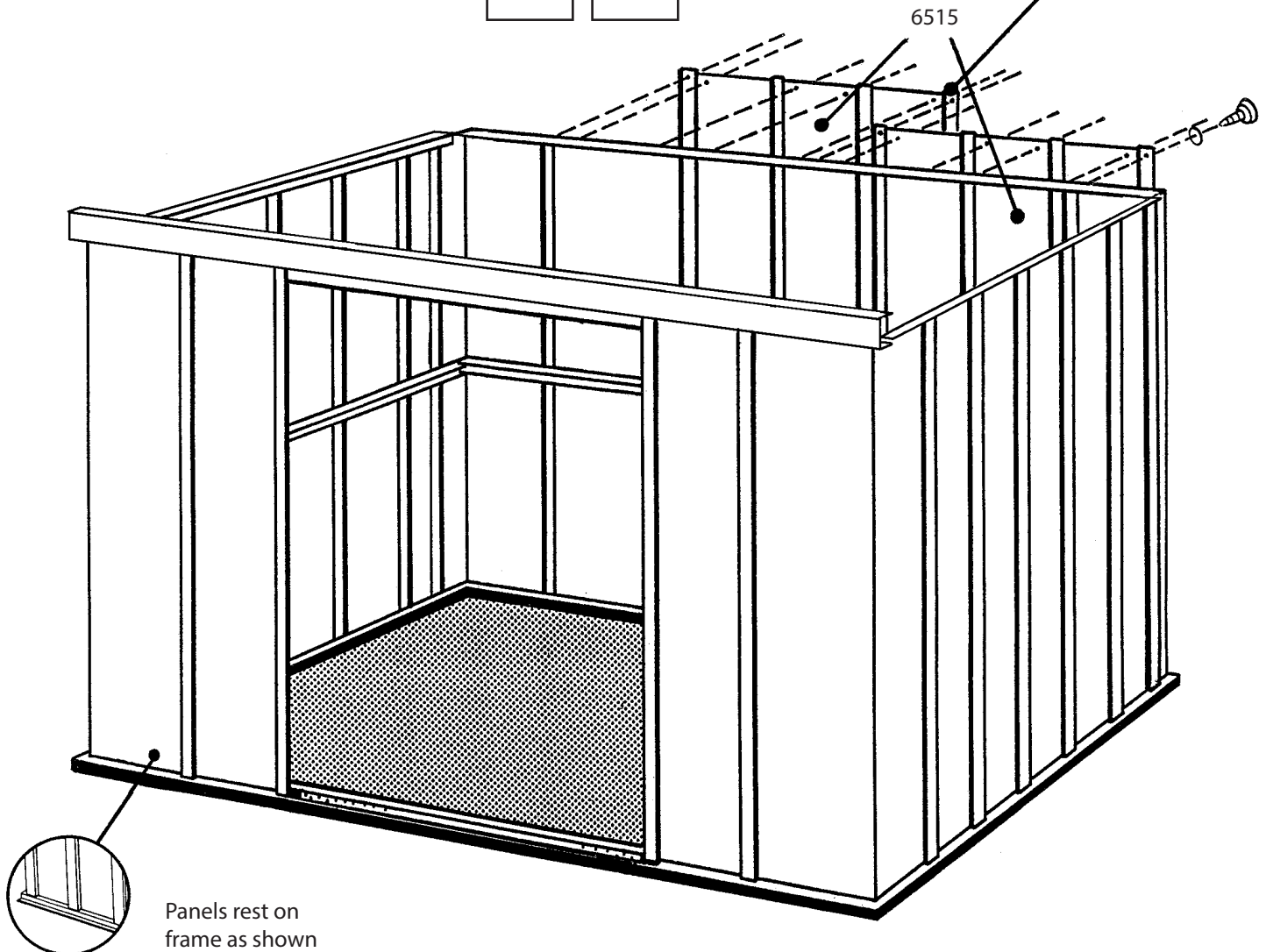
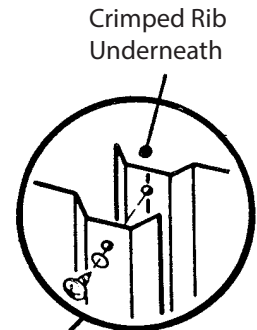

Step 6

Parts Needed For Door Jamb

9369 Door Jamb (2)

YV19

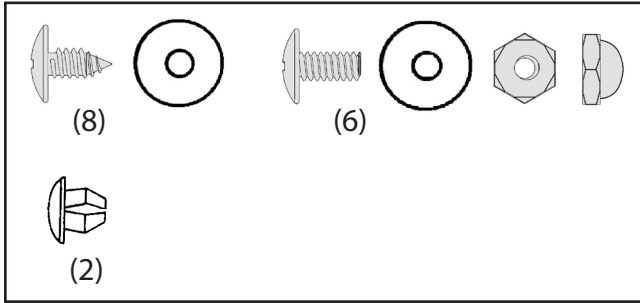

The door jambs reinforce the door opening and provide an attractive trim. Follow these steps for both door jambs.

1 Fasten a door jamb to the front panel with three bolts, nuts and acorn nuts, as shown. Push a plug into hole at center of jamb, closest to door opening.

2 Fasten the top of the door jamb to the door track with two screws. Do the same for the bottom into frame.

Repeat steps 1 and 2 for the opposite door jamb.

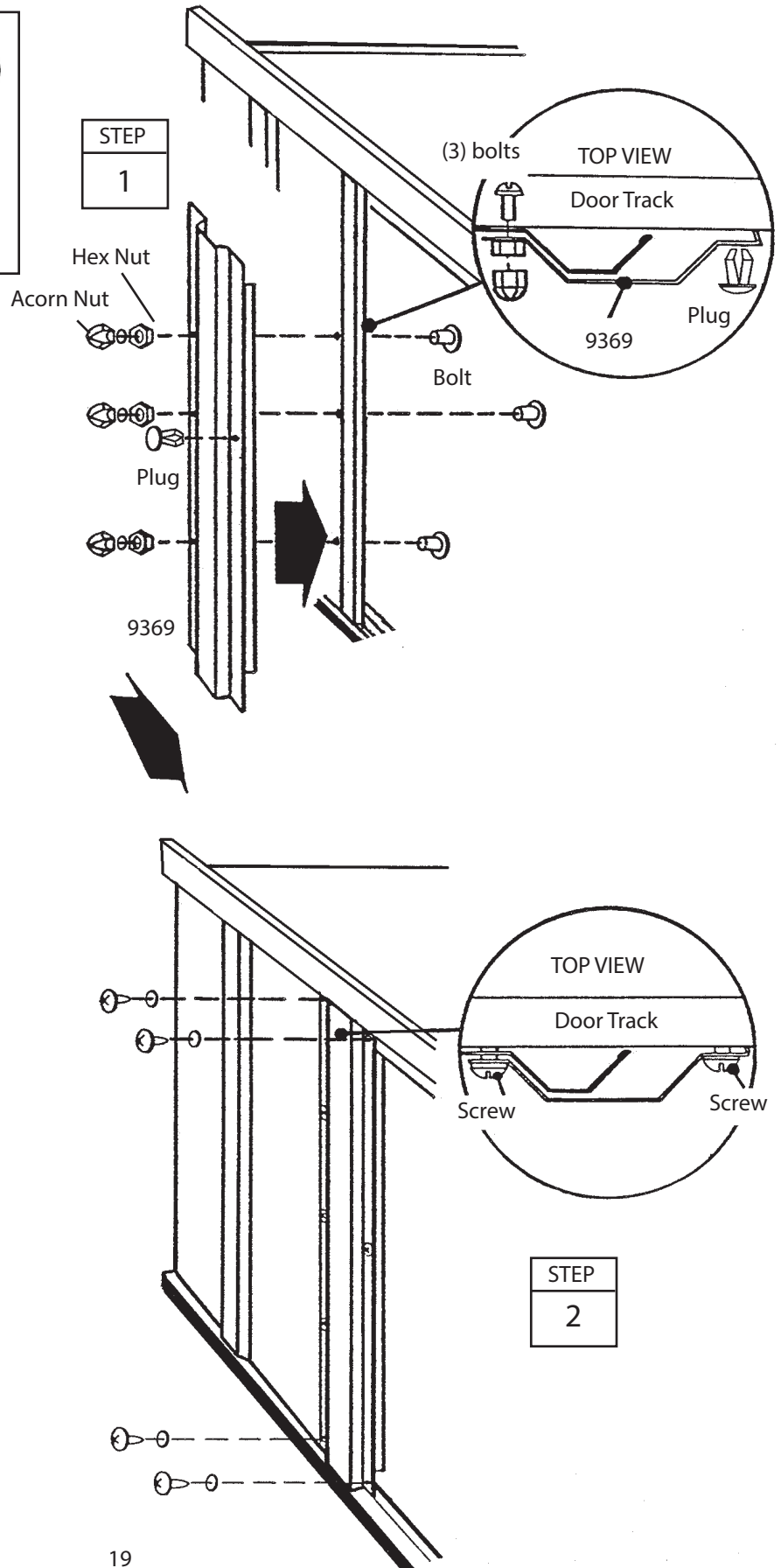

Step 7

Parts Needed For Roof Beam

10569 Roof Beam (1)

YV20

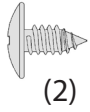

1 The dimension stated below measures from the end of the angle towards the front of the building. Fasten the roof beam, small holes on top, to the side wall angle with screws.

STEP
1

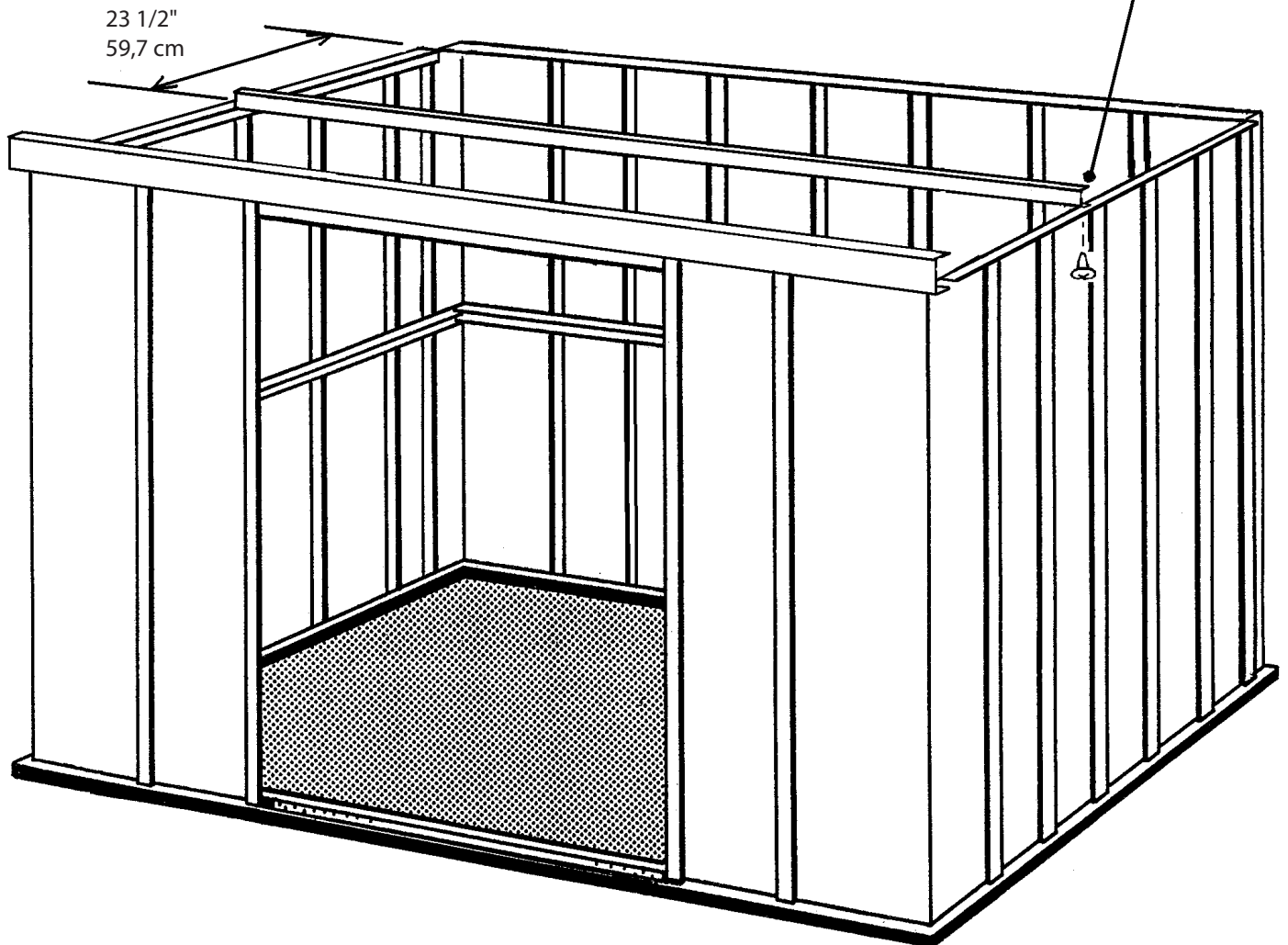

Step 8

YV21

Parts Needed For Right/Left Roof Panels

10558 Right Roof Panel (1)
80011 Left Roof Panel (1)

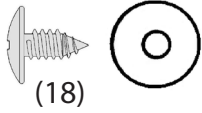

2 Position a right roof panel at the right side and fasten to the header, roof beam and rear wall angle using screws as shown.

Installing the roof panels is best done with a step ladder. Begin installing roof panels at the right side of the building. Each screw and bolt in the roof requires a washer.

3 Install the left roof panel 80011 on the left side in the position shown below.

NOTE

Measure the building diagonally again and make adjustments to make sure the building is square and level. This will make the roof panels fit better, and holes will align.

1 Locate the roof panels and find the right roof panel part number 10558.

STEP
3

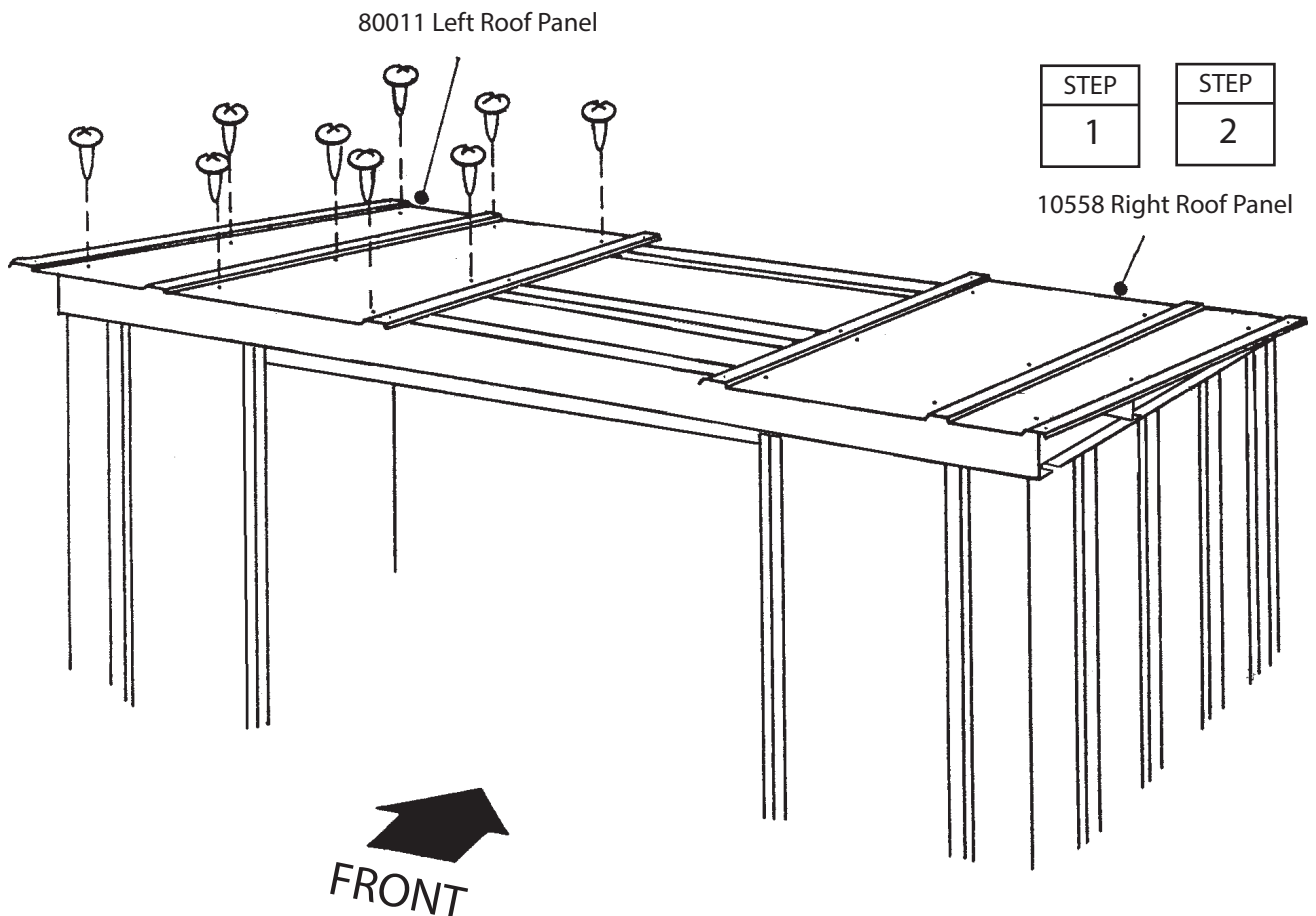

Step 9

YV22

Parts Needed For Roof Panel

10557 Roof Panel (1)

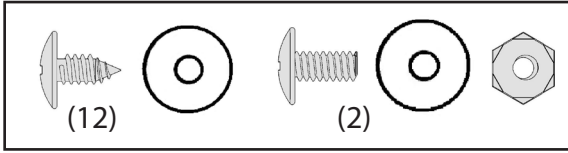

1 Install a roof panel 10557, in the position shown. Fasten middle of rib overlap with a bolt and nut.

NOTE

Narrow roof panel crimped rib is overlapped by wide rib of adjacent panel where possible.

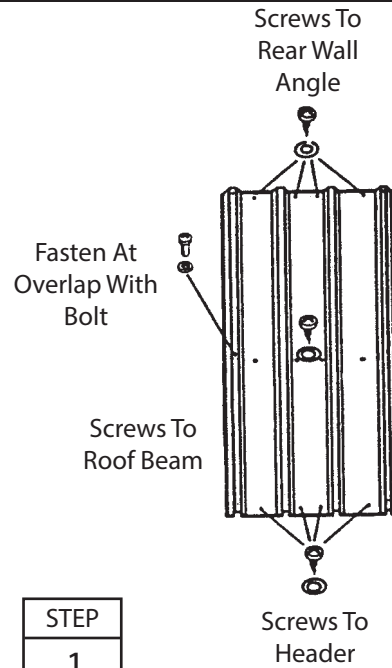

STEP
1

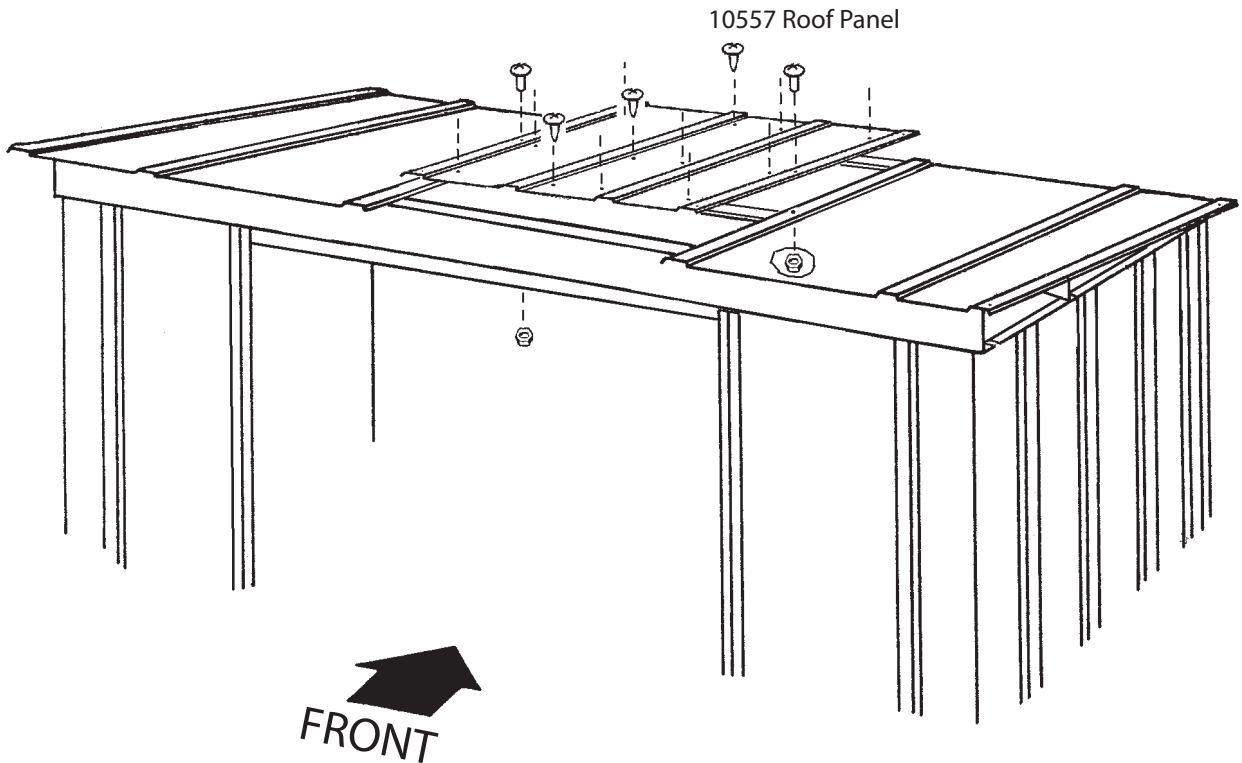

Step 10

YV23

Parts Needed For Gables

10562 Right Gable (1)
80015 Left Gable (1)

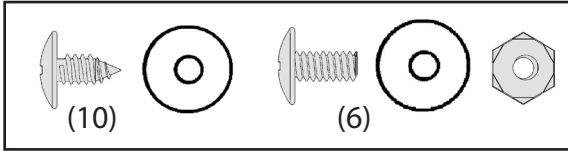

1 Position the right gable at the right end of the completed roof by tucking top edge inside the rib of the right roof panel and sliding the lower leg in between the leg of the side wall angle and top edge of the wall panels.

2 Fasten to the right roof panel, side wall angle and front header using screws, bolts and nuts as shown.

3 Repeat steps 1 and 2 for the left gable.

NOTE
The front leg of the gable must be positioned inside of the front header.

STEP
1

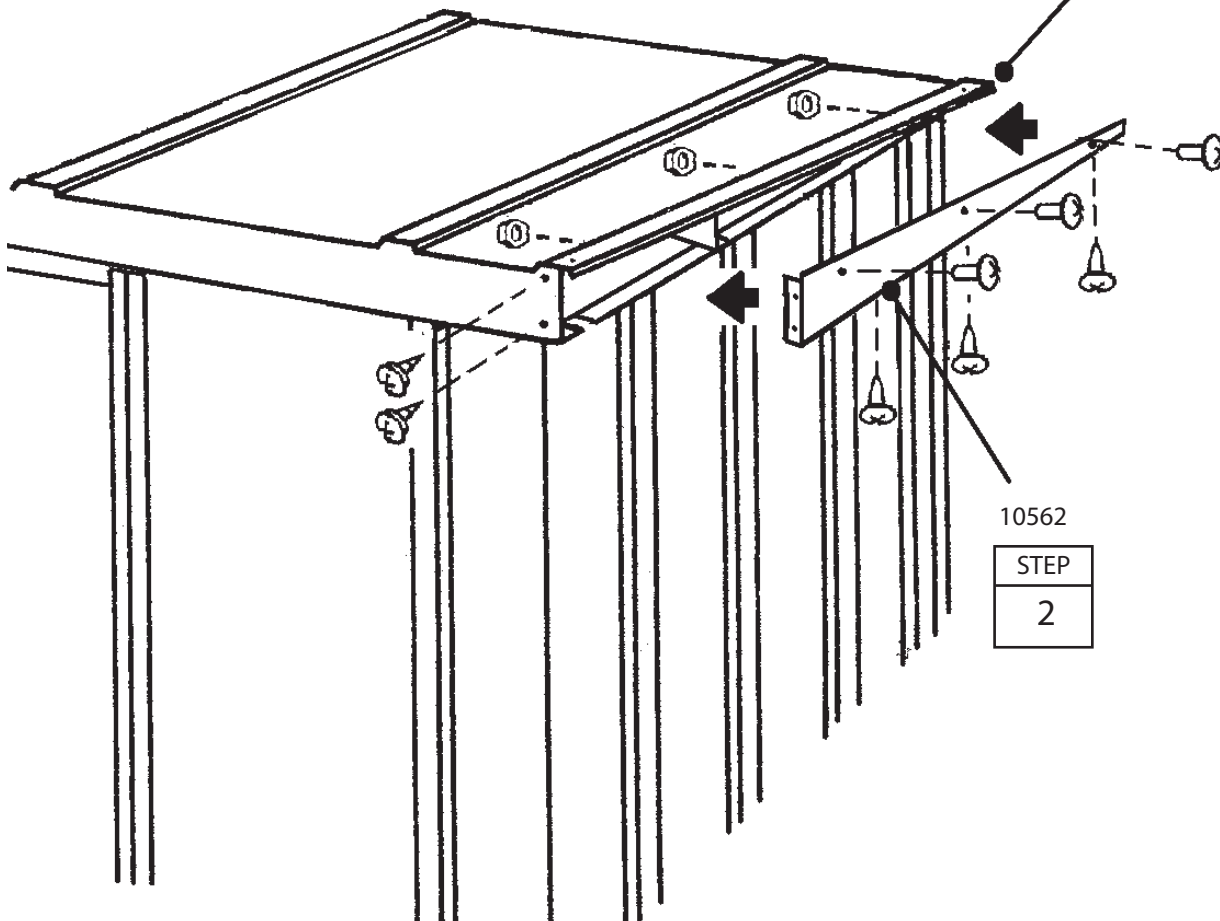
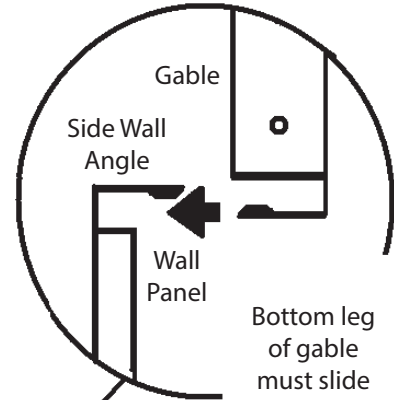

Step 11

YV24

Parts Needed For Roof Trim

80002 Roof Trim (2)

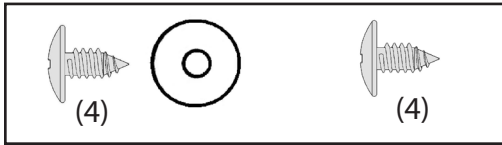

1 Attach the roof trim to the ends of the roof panels on the front and rear of the building using screws at each roof panel overlap.

2 Using your thumb and index finger, overbend the bottom flange of the roof trim at the corner inward enough so the right and left roof trim caps fit onto right and left corners.

3 Fasten the roof trim caps to the roof trim using a screw.

NOTE

A single screw fastens both trim pieces at the overlap.

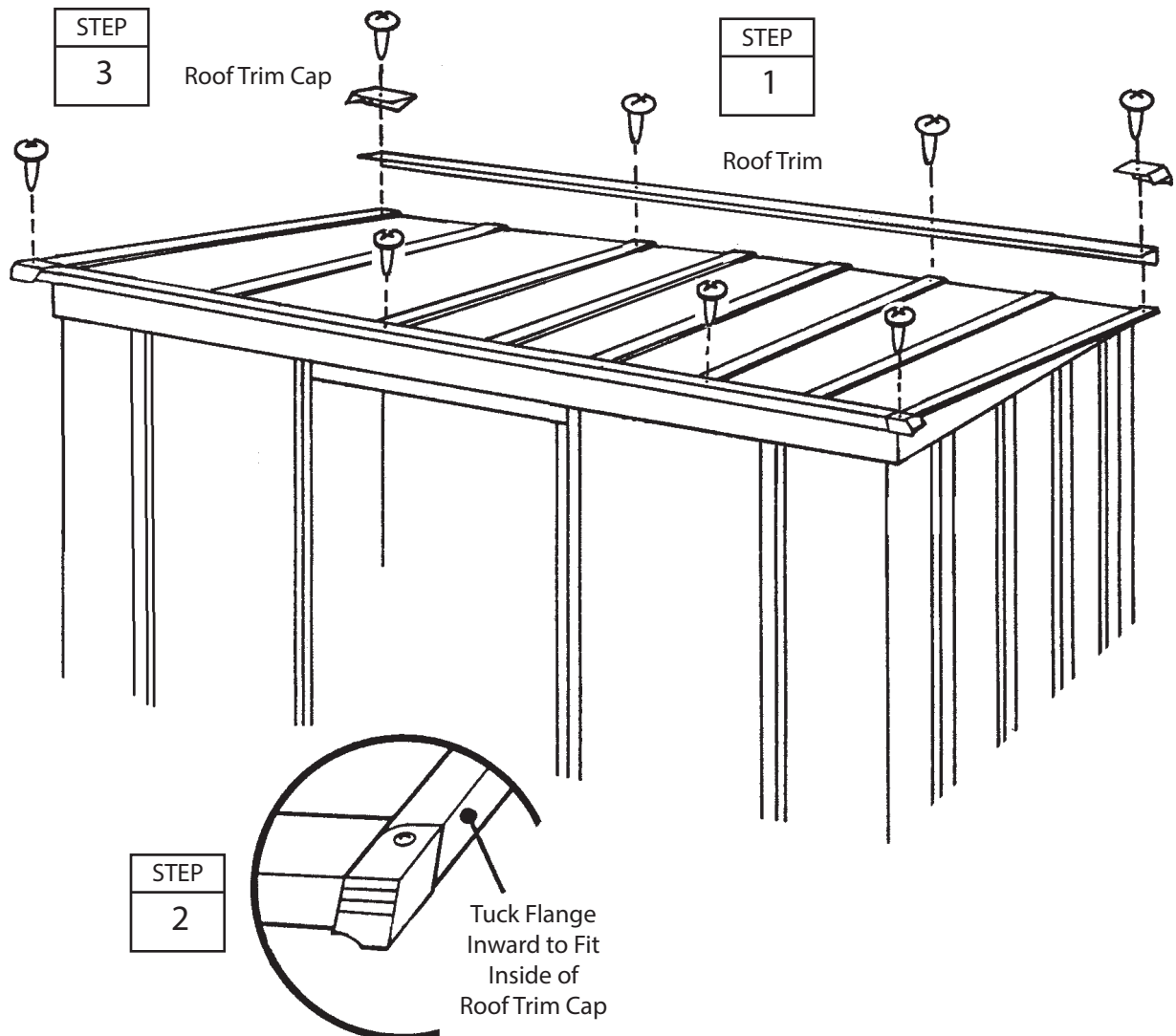

Step 12

Parts Needed For Door Assembly

6657 Door Handle Brace (2)
 10476 Right and Left Doors (2)
 10499 Horizontal Door Brace (4)

YV25

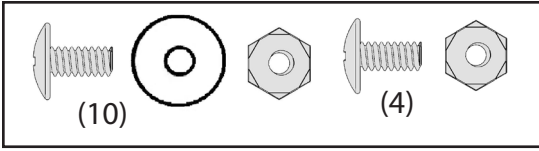

The steps on this page tell how to assemble the right door. You will perform exactly the same procedures for the left door. Each screw and bolt in the door requires a washer. Proceed as follows:

- 1 Attach the door handle brace and handle to the door with 1 bolt as shown. Don't tighten the bolt yet.
- 2 Swing the door handle brace up to the hole on the opposite side of the door and insert a bolt and nut.
- 3 Insert a second bolt in the door handle and tighten both bolts.
- 4 Put a horizontal door brace onto the top edge and bottom edge.
- 5 Attach the lower door guides and bolts as shown.
- 6 Repeat steps 1 through 5 for the left door.

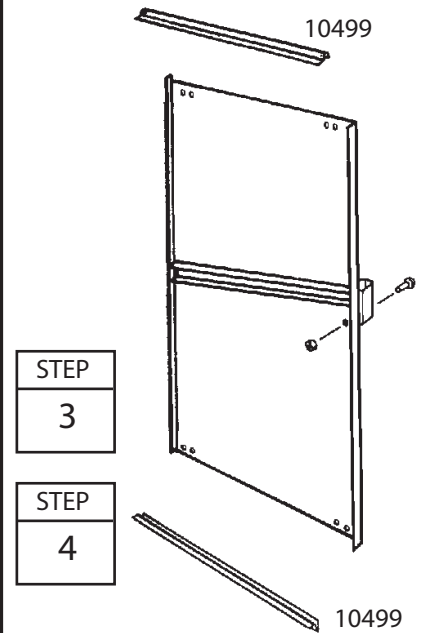
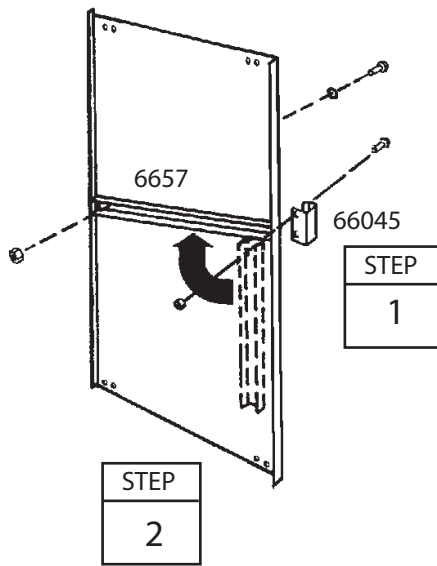
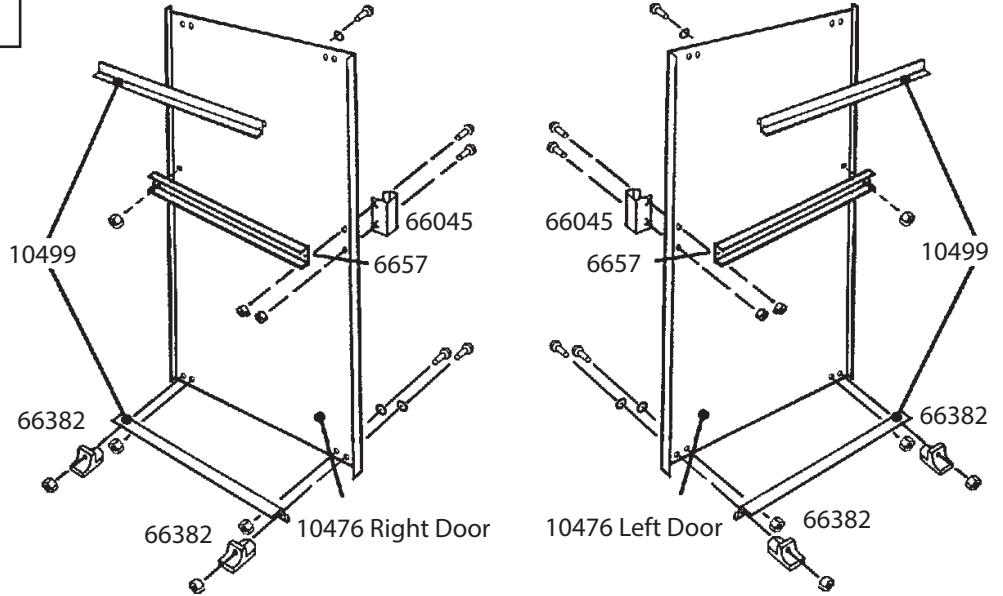

END VIEW SHOWING:

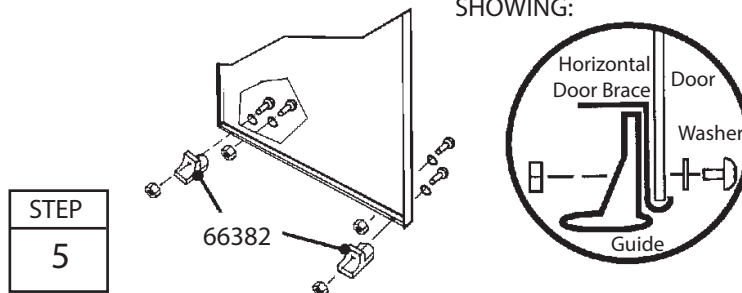

Step 13

Parts Needed For Door Installation & Adjustment

Right Door Assembly (1)
Left Door Assembly (1)

YV26

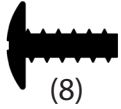

1 From inside the building, put the bottom of the right door assembly (on your left when you are inside the building) behind door jamb into the front frame track.

2 Position the top of the door so that that holes in the door line up with the holes in the door slides.

3 Fasten the door to the door slides using two #10Bx1/2" (13 mm) screws per door slide.

NOTE

The holes in the door slides allow you to adjust the doors. Place the door in the middle holes.

4 Repeat steps 1 through 3 for the left door.

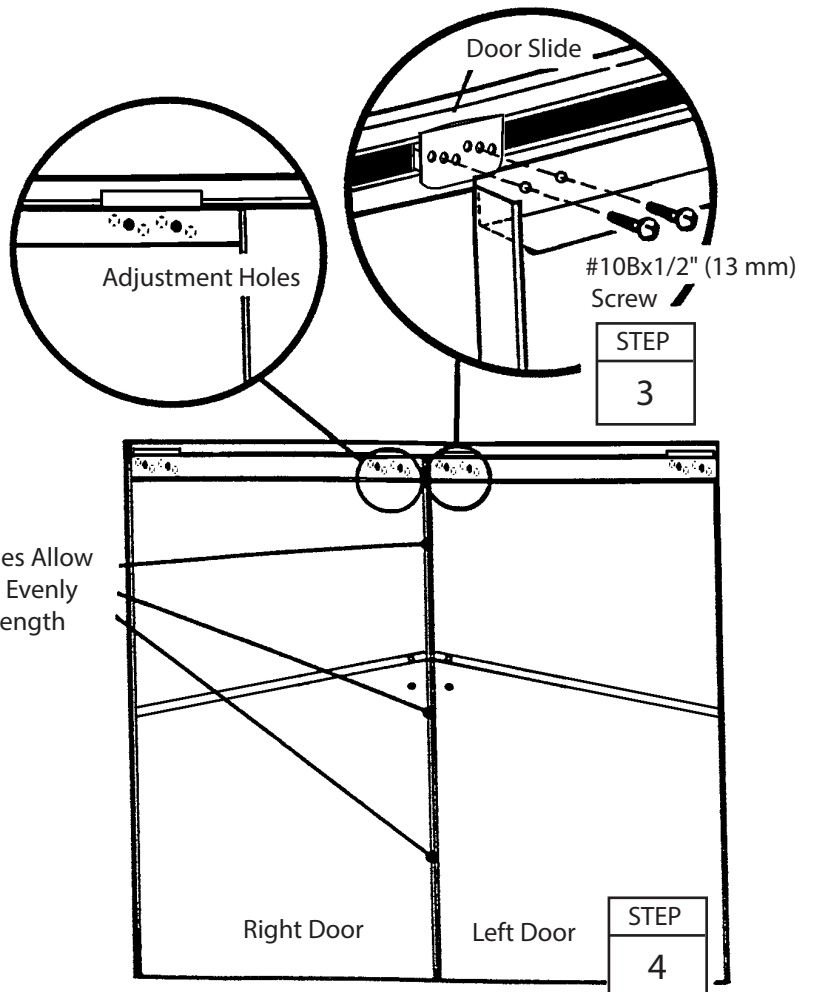
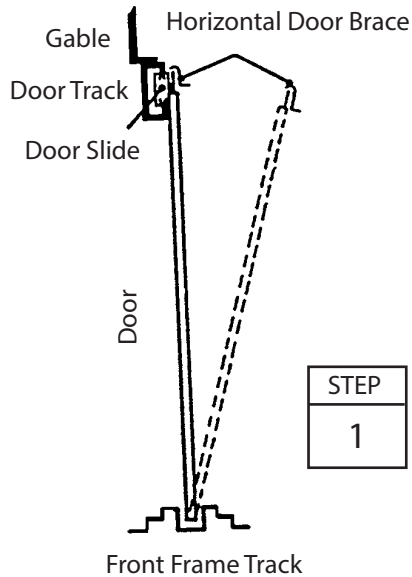

Keep this Owner's Manual and Assembly Instructions for future reference.

EP64□ PT64□ PT64EU□ PTG64□ PTG64EU□ EP64Z□

CZ28

Anchoring

Anchor your building at this time.

SOME FACTS ABOUT RUST

Rusting is a natural oxidizing process that occurs when bare metal is exposed to moisture. Problem areas include screw holes, unfinished edges, or where scrapes and nicks occur in the protective coating through normal assembly, handling and use. Identifying these natural rusting problem areas and taking some simple rust protection precautions can help to stop rust from developing, or stop it quickly as soon as it appears.

1. Avoid nicking or scraping the coating surface, inside and out.
2. Use all the washers supplied. In addition to protecting against weather infiltration, the washers protect the metal from being scraped by the screws.
3. Keep roof, base perimeter and door tracks free of debris and leaves which may accumulate and retain moisture. These can do double damage since they give off acid as they decay.
4. Touch up scrapes or nicks and any area of visible rust as soon as possible. Make sure the surface is free of moisture, oils, dirt or grime and then apply an even film of high quality touch-up paint.