

# Owner's Manual & Assembly Guide



Model No. RMA1012CL

# 10' x 12'

Nominal Size

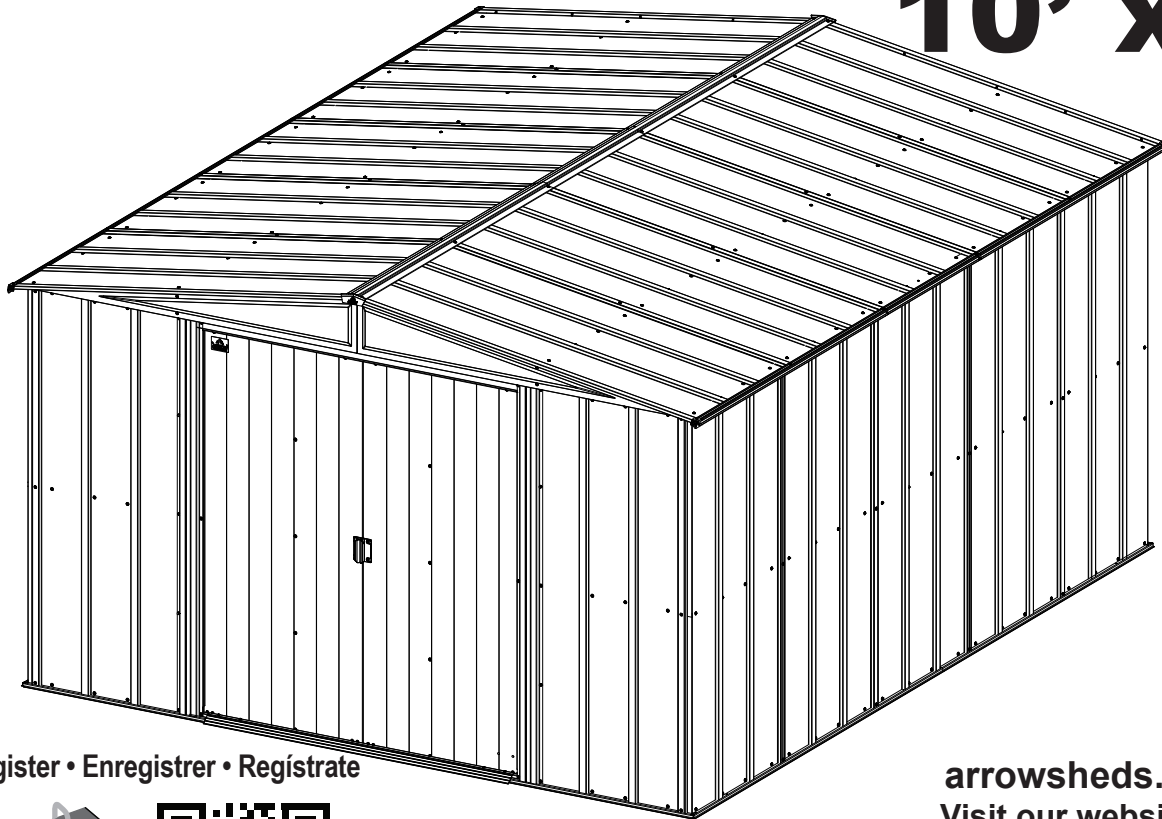

Register • Enregistrer • Registrare

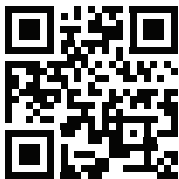

ShelterLogic.com/product-registration

**arrowsheds.com**  
Visit our website for  
compatible accessories

<b>Base Size</b>	121" x 143 1/4" 307,3 cm x 363,9 cm
------------------	--

## BUILDING DIMENSIONS

†Size rounded off to the nearest foot

For proper base construction see page 12

Approx.† Size	Storage Area	Exterior Dimensions (Roof Edge to Roof Edge)			Interior Dimensions (Wall to Wall)			Door Opening	
		Width	Depth	Height	Width	Depth	Height	Width	Height
10' x 12'	115 Sq. Ft. 693 Cu. Ft.	123 1/4"	145 3/4"	77 7/8"	118 1/4"	140 1/2"	76 5/8"	55 1/2"	65"
3,0 m x 3,7 m	10,7 m <sup>2</sup> 19,6 m <sup>3</sup>	313,1 cm	370,2 cm	197,8 cm	300,4 cm	356,9 cm	194,6 cm	141,0 cm	165,1 cm

\* See Inside for Detailed Safety Information.

Visitez notre site Web pour des accessoires compatibles

# Manuel de l'utilisateur et guide d'assemblage

**! attention**  
bords coupants\*

Toujours porter des gants pour réduire le risque de blessure ! 

Taille de la base 121" x 143 1/4"  
307,3 cm x 363,9 cm

## DIMENSIONS DU COFFRE

†Dimension arrondie au pied le plus proche

Taille † approx.	Zone d'entreposage		Dimensions extérieures (de bordure de toit à bordure de toit)			Dimensions intérieures (de paroi à paroi)			Ouverture de porte	
			Largeur	Profondeur	Hauteur	Largeur	Profondeur	Hauteur	Largeur	Hauteur
10' x 12'	115 Sq. Ft.	693 Cu. Ft.	123 1/4"	145 3/4"	77 7/8"	118 1/4"	140 1/2"	76 5/8"	55 1/2"	65"
3,0 m x 3,7 m	10,7 m <sup>2</sup>	19,6 m <sup>3</sup>	313,1 cm	370,2 cm	197,8 cm	300,4 cm	356,9 cm	194,6 cm	141,0 cm	165,1 cm

\* Voir les informations de sécurité détaillées à l'intérieur.

Besuchen Sie unsere Webseite für kompatibles Zubehör

# Pflege- & Montageanleitung

**! Vorsicht**  
scharfe Kanten\*

Zur Verringerung der Verletzungsgefahr müssen stets Handschuhe getragen werden! 

Bodenabmessungen 121" x 143 1/4"  
307,3 cm x 363,9 cm

## ABMESSUNGEN

†Angaben auf ganze Fuß gerundet

Ungefähre† Größe	Lagerfläche		Außenabmessungen (Dachkante zu Dachkante)			Innenabmessungen (Wand zu Wand)			Türöffnung	
			Breite	Tiefe	Höhe	Breite	Tiefe	Höhe	Breite	Höhe
10' x 12'	115 Sq. Ft.	693 Cu. Ft.	123 1/4"	145 3/4"	77 7/8"	118 1/4"	140 1/2"	76 5/8"	55 1/2"	65"
3,0 m x 3,7 m	10,7 m <sup>2</sup>	19,6 m <sup>3</sup>	313,1 cm	370,2 cm	197,8 cm	300,4 cm	356,9 cm	194,6 cm	141,0 cm	165,1 cm

\* Detaillierte Sicherheitsinformationen im Inneren.

## CAUTION / ATTENTION / VORSICHT

EN,FR,GE-04HN

- Care must be taken when handling various pieces of your building since many contain sharp edges.
- Faire preuve de précaution pour manipuler les différentes pièces de l'abri car elles présentent de nombreux bords coupants.
- Verschiedene Teile Ihres Schuppens müssen vorsichtig gehandhabt werden, denn viele haben scharfe Kanten.

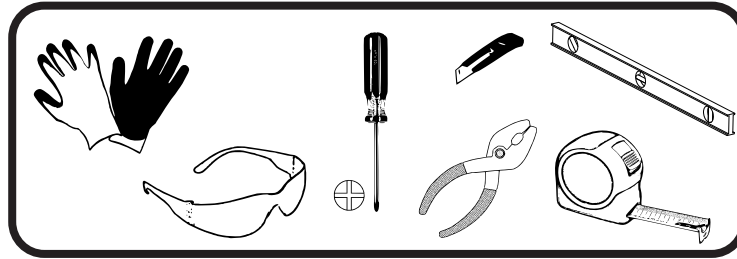

- Do NOT attempt to assemble your building before double checking that you have all the parts indicated in the parts lists. Any building left partially assembled may be seriously damaged by even light winds.
- Ne PAS tenter d'assembler l'abri avant d'avoir vérifié la présence de toutes les pièces figurant dans la liste des pièces. Tout abri laissé partiellement assemblé peut être gravement endommagé par des vents même légers.
- Versuchen Sie NICHT, Ihren Schuppen zu montieren, bevor Sie sich nochmals vergewissert haben, dass Sie alle in der Teileliste. Ein nur teilweise montiert zurückgelassener Schuppen kann bereits durch leichten Wind schwer beschädigt werden.
- Do NOT attempt to assemble your building on a windy day. The large panels can catch the wind like a "sail", making construction difficult and unsafe. **Watch the Weather Closely**
- Ne PAS tenter d'assembler l'abri en présence de vent. Les grands panneaux peuvent se comporter comme une voile et « battre » au vent, rendant la construction difficile et dangereuse. **Suivre la météo avec attention**
- Versuchen Sie NICHT, Ihren Schuppen an einem windigen Tag aufzustellen. Die großen, flächigen Bauteile könnten wie ein Segel vom Wind erfasst und herumgeschleudert werden, was die Aufstellarbeiten erschwert und gefährlich macht.
- Keep children and pets away from the worksite during construction and until the building is completely assembled. This will help avoid distractions and any accidents which may occur.
- Tenir les enfants et les animaux domestiques à l'écart du chantier durant la construction et jusqu'à ce que l'abri soit complètement assemblé. Cela évite les distractions et les accidents potentiels.
- Halten Sie Kinder und Haustiere während der Montage und bis der Schuppen vollständig aufgestellt ist vom Aufstellplatz fern. Dies hilft, Ablenkungen und damit einhergehende Unfälle zu verhindern.
- NEVER concentrate your weight on the roof of the building.
- NE JAMAIS concentrer son propre poids sur le toit de l'abri.
- Belasten Sie das Dach des Schuppens NIEMALS punktuell mit Ihrem Gewicht.
- Before assembling any parts, your base should be constructed and an anchoring system should be ready to use. Your building MUST be anchored to prevent wind damage.
- Avant de commencer à assembler des pièces, la base doit avoir été construite et le système d'ancrage doit être prêt à l'emploi. L'abri doit IMPÉRATIVEMENT être ancré pour éviter les dommages par le vent.
- Das Fundament sollte vor dem Zusammenbau der Teile gebaut und das Verankerungssystem nutzungsbereit sein. Ihr Schuppen MUSS verankert werden, um Schäden durch Wind zu verhindern.





- The best location is a level area with good drainage.
- Le meilleur emplacement sera une surface de niveau à bon drainage.
- Der bestmögliche Bauplatz ist eben mit einer guten Drainage.
  
- Allow enough space outside the building to be able to access the roof with a ladder.
- Laissez suffisamment d'espace à l'extérieur du bâtiment pour être en mesure d'accéder à la toiture avec une échelle.
- Es muß außerdem genügend Platz außerhalb des Gerätehauses vorgesehen werden, damit die Blechschrauben von außen aus verschraubt werden können.
- **Use Teamwork:** Two or more people are required to assemble your building.
- **Travailler en équipe:** Deux personnes ou plus sont nécessaires pour assembler l'abri.
- **Arbeiten Sie im Team:** Mindestens zwei Personen werden für die Montage des Gerätehauses benötigt.

**CARE & MAINTENANCE / SOINS ET ENTRETIEN / PFLEGE & INSTANDHALTUNG**

- DO NOT use power washing to clean your shed.
- NE PAS utiliser de jet sous haute pression pour nettoyer l'abri.
- Reinigen Sie Ihren Schuppen NICHT mit dem Hochdruckreiniger.
  
- Combustibles and corrosives must be stored in air tight containers designed for chemical and/or combustible storage. Corrosive chemicals such as fertilizers, pesticides and herbicides should be cleaned off the interior and exterior surfaces immediately. Rust caused by chemical damage is not covered by the warranty.
- Les matières combustibles et corrosives doivent être entreposées dans des contenants étanches à l'air conçus pour l'entreposage de produits chimique et/ou combustibles. Les produits chimiques corrosifs tels que les engrais, pesticides et herbicides doivent immédiatement être nettoyés des surfaces intérieures et extérieures. La rouille causée par des produits chimiques n'est pas couverte par la garantie.
- Brennbare und ätzende Stoffe müssen in luftdichten Behältern gelagert werden, die zur Lagerung von Chemikalien und/oder Brennstoffen vorgesehen sind. Ätzende Chemikalien wie z. B. Dünger, Insektenvernichter und Unkrautvernichter sollten sofort von den Innen- und Außenflächen abgewischt werden. Durch die Lagerung von Chemikalien entstandener Rost wird nicht von der Gewährleistung abgedeckt.

**Rust protection precautions / Des mesures de protection contre la rouille / Rostschutzmaßnahmen**

- Avoid nicking or scraping the coating surface, inside and out.
- Éviter d'entailler ou de rayer le revêtement de surface, à l'intérieur comme à l'extérieur.
- Vermeiden Sie es, die Oberflächenbeschichtung an der Innen- und Außenseite zu beschädigen oder zu verkratzen.
  
- Keep roof, base perimeter and door free of debris.
- Nettoyer le toit, le pourtour de la base et les rails de porte de tous débris.
- Halten Sie das Dach, den Bodenbereich und die Türführungen stets frei von Verunreinigungen.
  
- Touch up scrapes or nicks and any area of visible rust as soon as possible.
- Retoucher les entailles et égratignures et toute surface de rouille visible dès que possible.
- Bessern Sie Kratzer oder Beschädigungen und alle Bereiche mit sichtbarem Rost so schnell wie möglich aus.

Key No. Rep. Lfd. Nr.	Part No. Réf. pièce Art.-Nr.	Part Description	Description de la pièce	Bezeichnung	Qty. Qté Menge	Part Views Profils de pièces Vor-handen
1	65103	Hex Nut (#8-32) / Écrou hexagonal (8-32) / Sechskantmutter (#8-32)			177	
2	65923	Small Bolt (#8-32 x 3/8) (10 mm) / Petit boulon (8-32 x 3/8) (10 mm) / Kleine Maschinenschraube (#8-32 x 3/8) (10 mm)			177	
3	65004	Small Screw (#8AB x 5/16) (8 mm) / Petite vis (8AB x 5/16) (8 mm) / Kleine Blechschraube (#8AB x 5/16) (8 mm)			404	
4	65900	Black Screw (#10B x 1/2) (13 mm) / Vis noire (#10B x 1/2) (13 mm) / Schwarze Schrauben (#10B x 1/2) (13 mm)			8	
5	65109	Acorn Nut (#8-32) / Écrou borgne (#8-32) / Hutmutter (#8-32)			4	

The fasteners used in each step are shown actual size at the top of each page. If you are unsure which fastener to use, hold it up to the picture and use the one that matches.







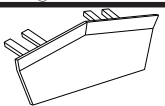
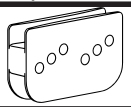
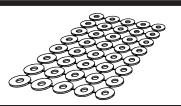
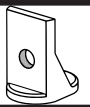

Les éléments de visserie utilisés à chaque étape sont représentés en taille réelle en haut de chaque page. En cas de doute sur le type de visserie à utiliser, les placer sur l'image et utiliser celui qui correspond.

Die in den jeweiligen Schritten verwendeten Verbindungselemente werden am oberen Seitenrand jeweils in tatsächlicher Größe gezeigt. Falls Sie unsicher sind, welches Verbindungselement Sie verwenden sollen, dann halten Sie es vor das Bild und verwenden Sie dasjenige, das passt.

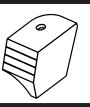
# HARDWARE LIST

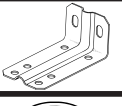
## LISTE DE LA VISSERIE KLEINTEILELISTE









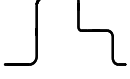

EN,FR,GE-061C

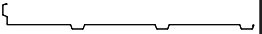
Key No. Rep. Lfd. Nr.	Part No. Réf. pièce Art.-Nr.	Part Description	Description de la pièce	Bezeichnung	Qty. Qté Menge	Part Views Profils de pièces Vor-handen
6	66045	Handle / Poignée de porte / Türgriff			2	
7	67468	Peak Cap / Embout de faite / Firstkappe			2	
8	66769	Door Slide / Coulisseau de porte / Türgleiter			4	
9	66646	Washer Sheet / Plaque de rondelles / Unterlegscheiben			12	
10	66382	Lower Door Guide / Guide de porte inférieure / Untere Türführung			4	
11	66183L	Left Roof Trim Cap / Embout de garniture de toit gauche / Eckabschluß link			2	
12	66183R	Right Roof Trim Cap / Embout de garniture de toit droit / Eckabschluß recht			2	
13	5971	Roof Beam Bracket / Attache de poutre de toit / Dachbalkenträger			4	
14	6228	Track Support / Support de rail / Stützwinkel			2	
15	67545	Weather Stripping / Ruban de calfeutrage / Dichtungsband			1	
16	30028	Nameplate / Plaque signalétique / Typenschild			1	
17	66775	Plug (Door Color) / Bouchon (Couleur de la porte) / Stopfen (Türfarbe)			2	

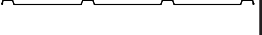
# PARTS LIST

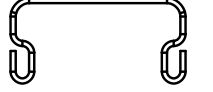
LISTE DES PIÈCES  
TEILELISTE

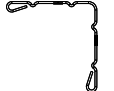
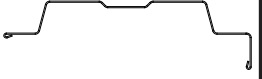
EN,FR,GE-07LO

Key No. Rep. Lfd. Nr.	Part No. Réf. pièce Art.-Nr.	Part Description	Description de la pièce	Bezeichnung	Qty. Qté Menge	Part Views Profils de pièces Vor-handen
18	10392	Side Floor Frame /	latéral Cadre de plancher /	Seitenbodenrah- men	4	
19	8936	Rear Floor Frame /	Cadre de plancher arrière /	Bodenrahmen hinten	2	
20	8934	Ramp /	Seuil /	Türschwelle	1	
21	9367	Front Floor Frame /	Cadre de plancher avant /	Bodenrahmen vorne	2	
22	6633	Corner Panel /	Panneau de coin /	Eckblech	4	
23	9374	Wall Panel /	Panneau de mur /	Wandblech	2	
24	6627	Wall Panel /	Panneau de mur /	Wandblech	10	
25	10389	Rear Wall Channel /	Longeron de mur /	Rückwand verstrebung	2	
26	10390	Side Wall Channel /	Longeron de mur latéral /	Seitenrückwand verstrebung	4	
27	9365	Wall Channel Front /	Canal mur avant /	Vorderseite Kanalwand	2	
28	10393	Side Wall Angle /	Cornière de mur latéral /	Seitenwandwinkel	4	
29	5986	Rear Wall Angle /	Cornière arrière /	Rückwandwinkel	2	
30	9370	Door Jamb /	Jambage de porte /	Türpfosten	2	
31	6403	Door Track Splice /	Raccord de rail de porte /	Türschienenlasche	1	

# PARTS LIST

LISTE DES PIÈCES  
TEILELISTE

EN,FR,GE-08LO



Key No. Rep. Lfd. Nr.	Part No. Réf. pièce Art.-Nr.	Part Description	Description de la pièce	Bezeichnung	Qty. Qté Menge	Part Views Profils de pièces Vor-handen
32	9366	Door Track / Rail de porte / Türlaufschiene			2	
33	6635	Gable Brace / Renfort de pignon / Giebelverstärkung			2	
34	6000	Right Gable / Pignon droit / Giebel rechts			2	
35	6001	Left Gable / Pignon gauche / Giebel links			2	
36	10397	Roof Beam / Poutre de toit / Dachträger			8	
37	6640	Right Roof Panel / Panneau de toit droit / Dachblech rechts			2	
38	6641	Left Roof Panel / Panneau de toit gauche / Dachblech links			2	
39	6529	Roof Panel / Panneau de toit / Dachblech			6	
40	6014	Roof Trim / Garniture de toit / Dachabschlussleiste			2	
41	6015	Roof Trim / Garniture de toit / Dachabschlussleiste			4	
42	6868	Ridge Cap / Faîtage / Firstabdeckung			1	
43	6869	Ridge Cap / Faîtage / Firstabdeckung			2	
44	6300	Vertical Door Channel / Canal d'ouverture verticale de la porte / Vertikale Türschiene			2	
45	80277	Door Panel / Panneau porte / Tür			2	



# PARTS LIST

LISTE DES PIÈCES  
TEILELISTE

EN,FR,GE-091C

Key No. Rep. Lfd. Nr.	Part No. Réf. pièce Art.-Nr.	Part Description	Description de la pièce	Bezeichnung	Qty. Qté Menge	Part Views Profils de pièces Vor-handen
46	10497	Horizontal Door Brace / Renfort d'ouverture horizontale de la porte / Horizontale Türschiene			4	
47	3719	Door Handle Brace / Renfort de poignée de porte / Türgriffversteifung			2	
48	69835	Edge Trim(Green) / Garniture de bordure (verte) / Kantenschutz (Grün)			4	

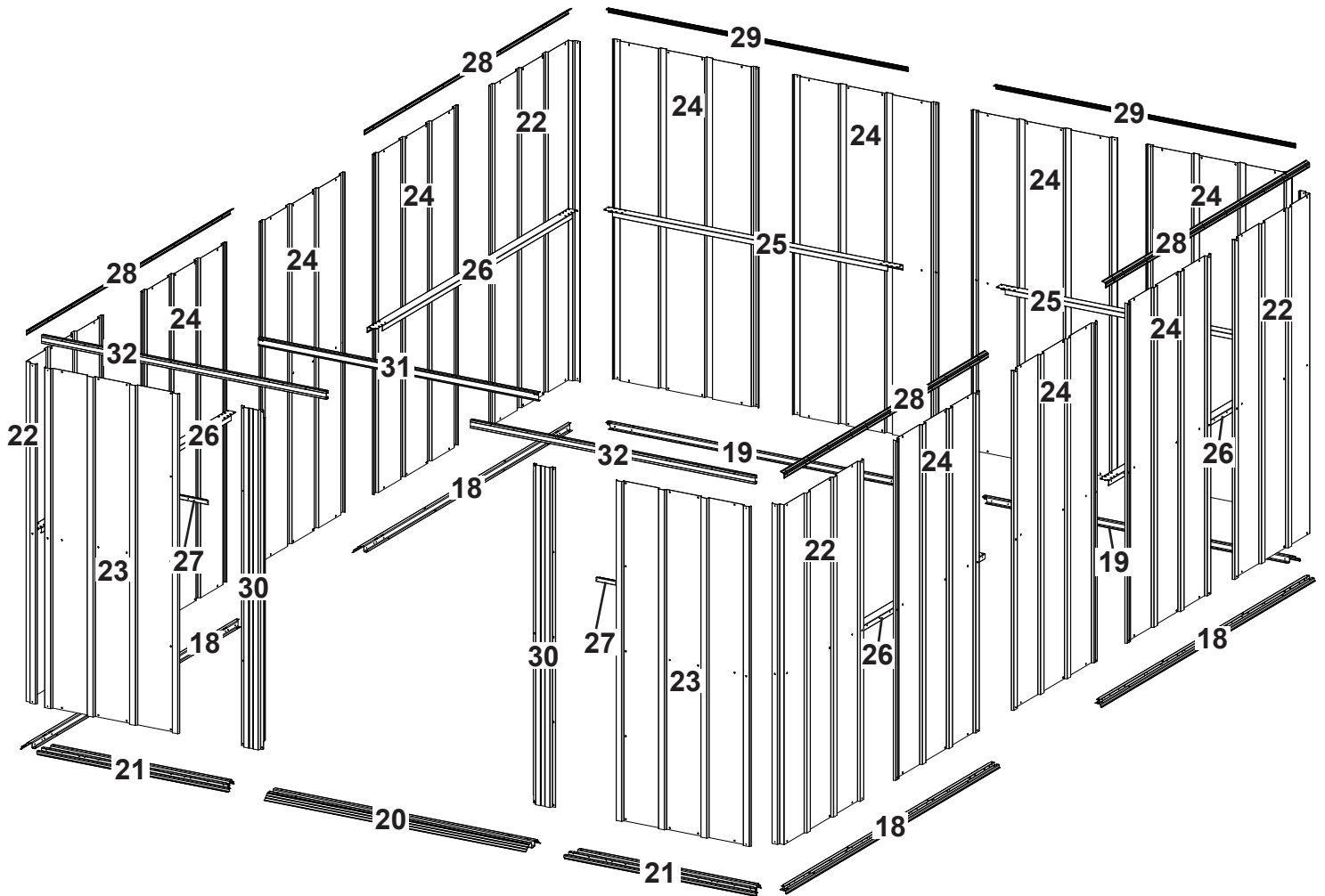

# ASSEMBLY BY KEY NO.

PIÈCES PAR N° DE REPÈRE  
MONTAGE NACH LFD. NR.

EN,FR,GE-111C

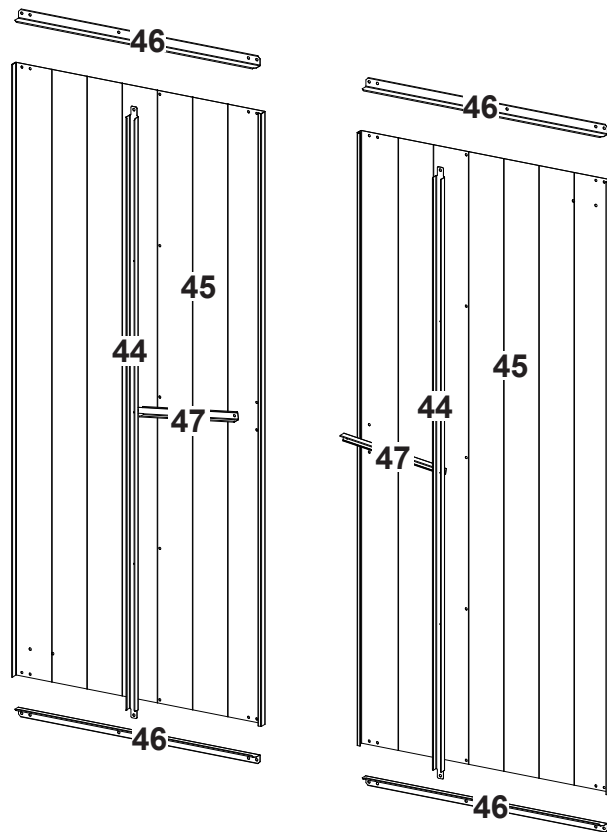
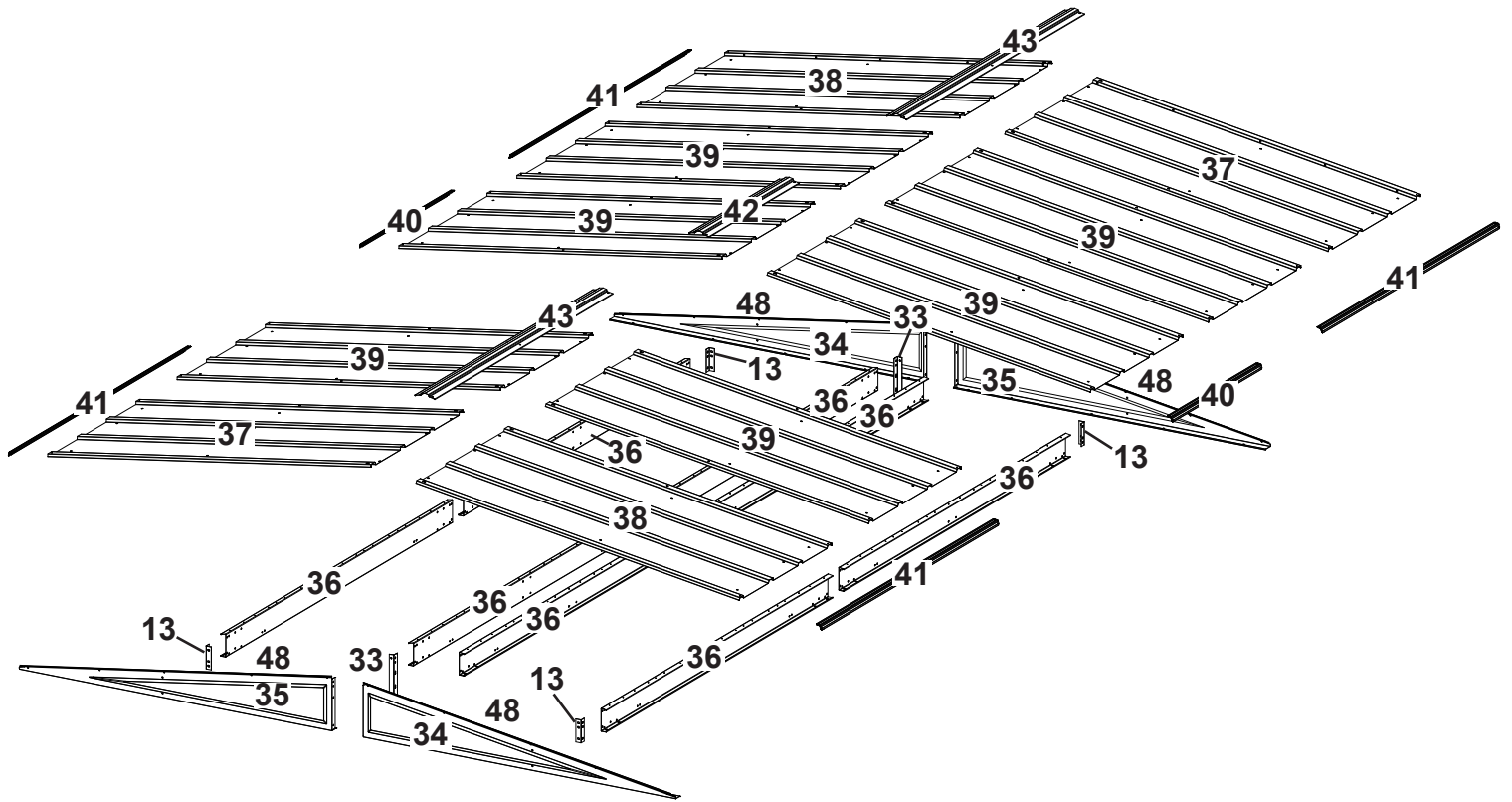

Wood Platform / Plateforme en bois

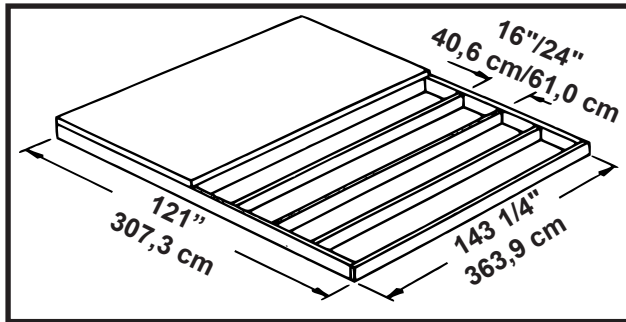

Concrete Slab / Dalle en béton

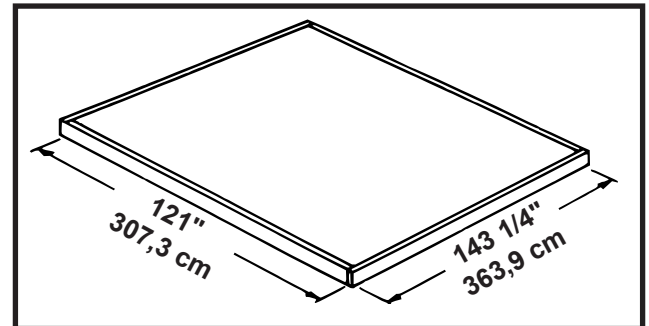

## \* IMPORTANT \*

The base **MUST** be flat and level to provide adequate support for your building, otherwise the **PRE-DRILLED HOLES WILL NOT ALIGN AND IT CANNOT BE ASSEMBLED**. No matter which of the options below you choose for a base, an **ARROW ANCHORING KIT** is recommended as an effective method of properly securing your building after assembly is complete.

### **OPTION 1: Build directly on the ground**

### **OPTION 2: Wood Platform**

**NOTE:** Pressure Treated Lumber must **NOT** be used where it will make contact with your storage building. The properties of Pressure Treated Lumber will cause accelerated corrosion. **If Pressure Treated Lumber comes in contact with your storage building your warranty will be voided.** The platform should be level and flat (free of bumps, ridges, etc.) to provide good support for the building. The necessary materials may be obtained from your local lumber yard.

### **OPTION 3: Concrete Slab**

The slab should be at least 4" (10,2 cm) thick.

## \* IMPORTANT \*

La base **DOIT** être plate et de niveau pour fournir un support adéquat à votre bâtiment, sinon les trous **PRÉ-PERCÉS NE S'ALIGNERONT PAS ET ILS NE POURRONT PAS ÊTRE ASSEMBLÉS**. Quelque que soit l'option ci-dessous choisie pour la base, un **NÉCESSAIRE D'ANCRAGE ARROW** est recommandé pour amarrer solidement l'abri une fois que le montage est terminé.

### **OPTION 1 : Construire à même le sol**

### **OPTION 2 : Plateforme en bois**

**REMARQUE :** Ne **PAS** utiliser de bois traité sous pression aux points de contact avec l'abri. **Le bois traité sous pression contribue à accélérer la corrosion. Le contact de bois traité sous pression avec l'abri aura pour effet d'annuler la garantie.** La plateforme doit être plate et de niveau (sans bosses, arêtes, etc.) afin d'offrir un bon support à l'abri. Les matériaux nécessaires peuvent s'obtenir auprès d'un fournisseur de bois d'œuvre local.

### **OPTION 3 : Dalle en béton**

La dalle doit avoir au moins 4 "(10,2 cm) d'épaisseur.

Plattform aus Holz

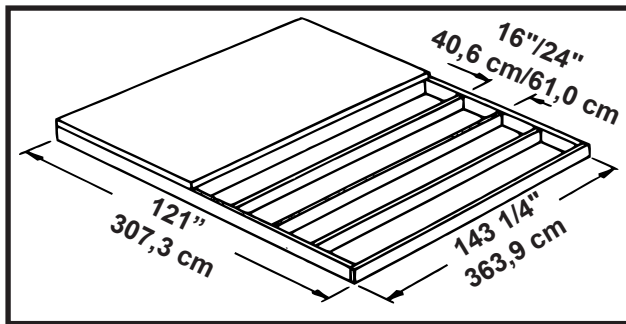

Bodenplatte aus Beton

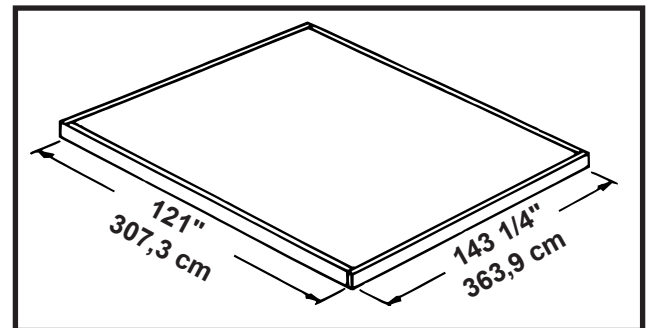

## **\*WICHTIG\***

Der Sockel **MUSS** flach und eben sein, um eine angemessene Unterstützung für Ihr Gebäude zu gewährleisten. Andernfalls werden die **VORGEBOHRTEN LÖCHER NICHT AUSGERICHTET UND ES KANN NICHT ZUSAMMENGEBAUT WERDEN.** Unabhängig davon, für welche der nachfolgend genannten Möglichkeiten Sie sich als Fundament entscheiden, empfiehlt sich ein **ARROW-VERANKERUNGSKIT** als wirkungsvolle Methode zur ordnungsgemäßen Sicherung Ihres Bauwerks nach Abschluss der Montagearbeiten.

### **MÖGLICHKEIT 1: Direkt auf dem Untergrund (Erde)**

### **MÖGLICHKEIT 2: Plattform aus Holz**

**HINWEIS:** An Stellen, an denen es mit Ihrem Geräteschuppen in Kontakt kommen würde, darf kein kesseldruckimprägniertes Holz verwendet werden. Kesseldruckimprägniertes Holz hat Eigenschaften, die zu beschleunigter Korrosion führen. **Wenn** kesseldruckimprägniertes Holz mit Ihrem Geräteschuppen in Kontakt kommt, wird Ihre **Garantie ungültig.**

### **MÖGLICHKEIT 3: Bodenplatte aus Beton**

Die Bodenplatte sollte **wenigstens 10,2 cm** stark sein.

# 1: FLOOR FRAME

CADRE DE PLANCHER  
BODENRAHMEN

EN,FR,GE-14IBa

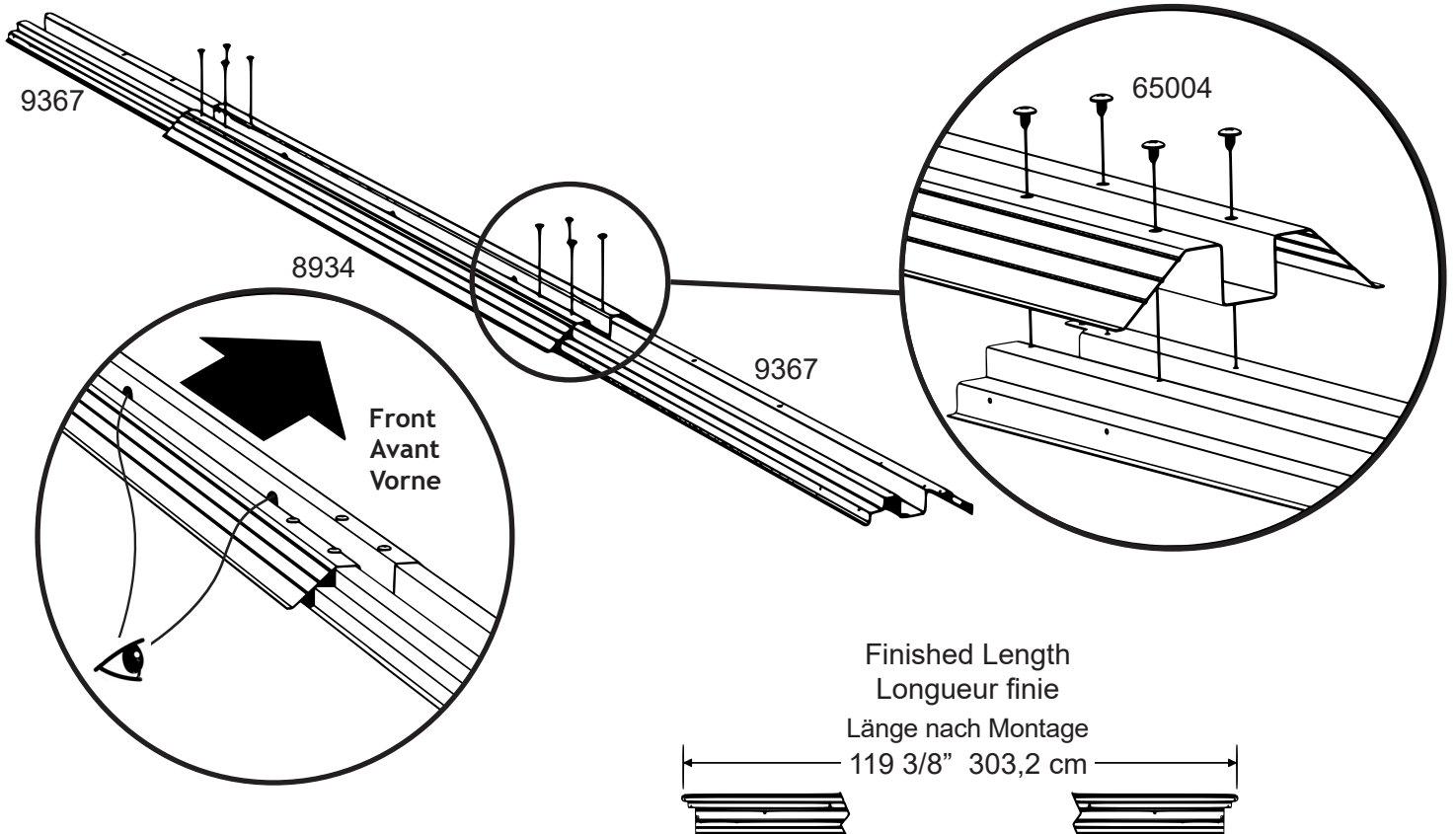
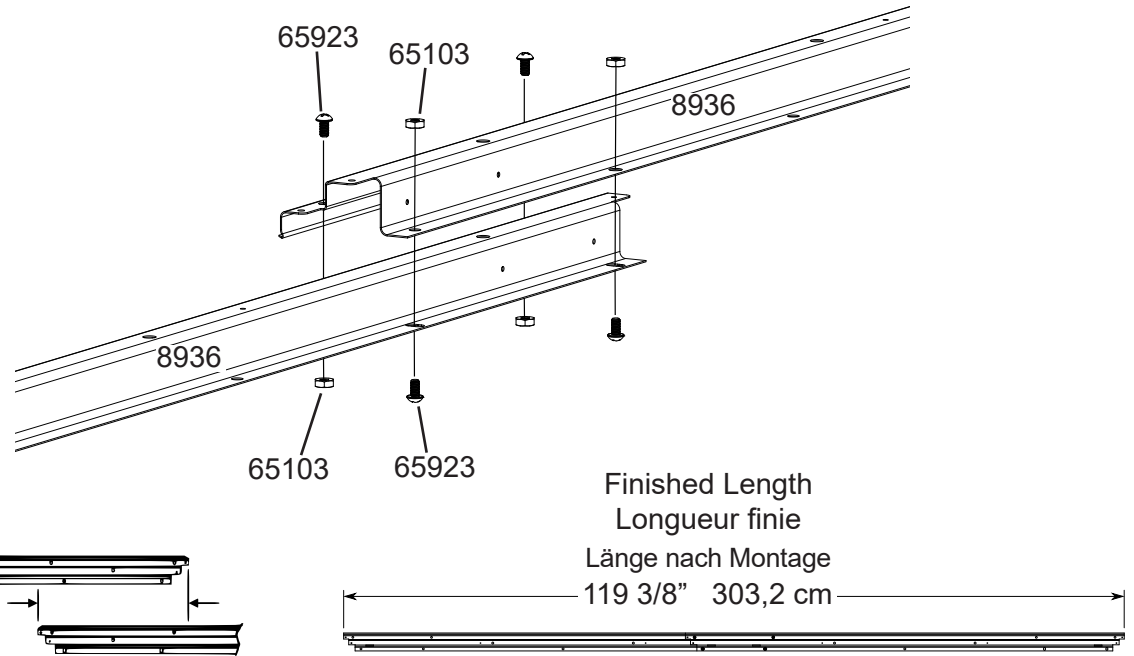
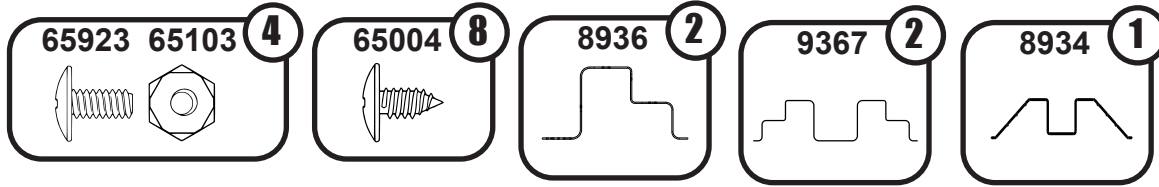

# 1: FLOOR FRAME

CADRE DE PLANCHER  
BODENRAHMEN

EN,FR,GE-151C

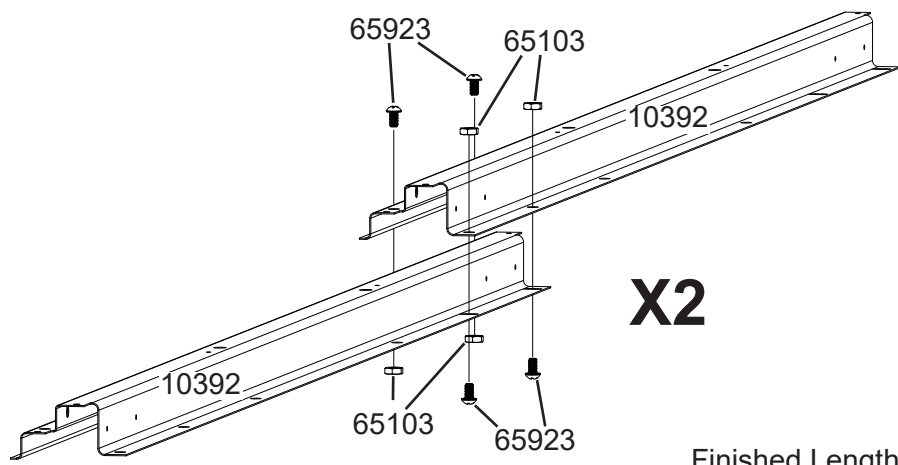
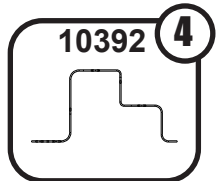
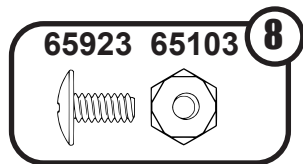

11 7/8" 30,2 cm  
Overlap Length  
Longueur de  
chevauchement  
Überlappung

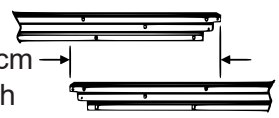

Finished Length  
Longueur finie  
Länge nach Montage

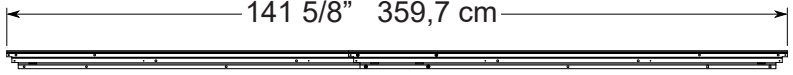

# 1: FLOOR FRAME

CADRE DE PLANCHER  
BODENRAHMEN

EN,FR,GE-161C

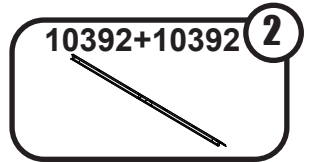
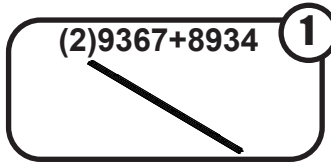
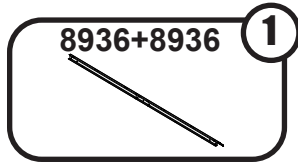
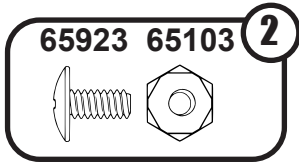
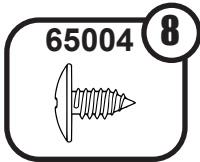

## NOTES:

Do NOT fasten your Floor Frames to your Base at this time. You will anchor your building after it is erected.

The Floor Frame must be BOTH square AND level or the holes will not line up properly.

Measure diagonally from corner to corner. When diagonal measurements are equal, the Frame is square.

## REMARQUES:

Ne PAS attacher les éléments de cadre de plancher à la base à ce stade. L'abri sera ancré une fois qu'il est assemblé.

Le cadre de plancher doit être À LA FOIS d'équerre et de niveau pour que les trous s'alignent correctement.

Mesurer en diagonale d'un coin à l'autre. Lorsqu'elles sont égales, le cadre de plancher est d'équerre.

## HINWEIS:

Befestigen Sie Ihre Bodenrahmen noch NICHT am Fundament. Sie verankern Ihr Bauwerk erst, nachdem es fertig aufgebaut ist.

Der Bodenrahmen muss SOWOHL rechtwinklig ALS AUCH waagrecht sein. Andernfalls fluchten die Löcher nicht richtig.

Messen Sie diagonal von Ecke zu Ecke. Wenn die diagonalen Abmessungen gleich sind, ist der Rahmen rechtwinklig.

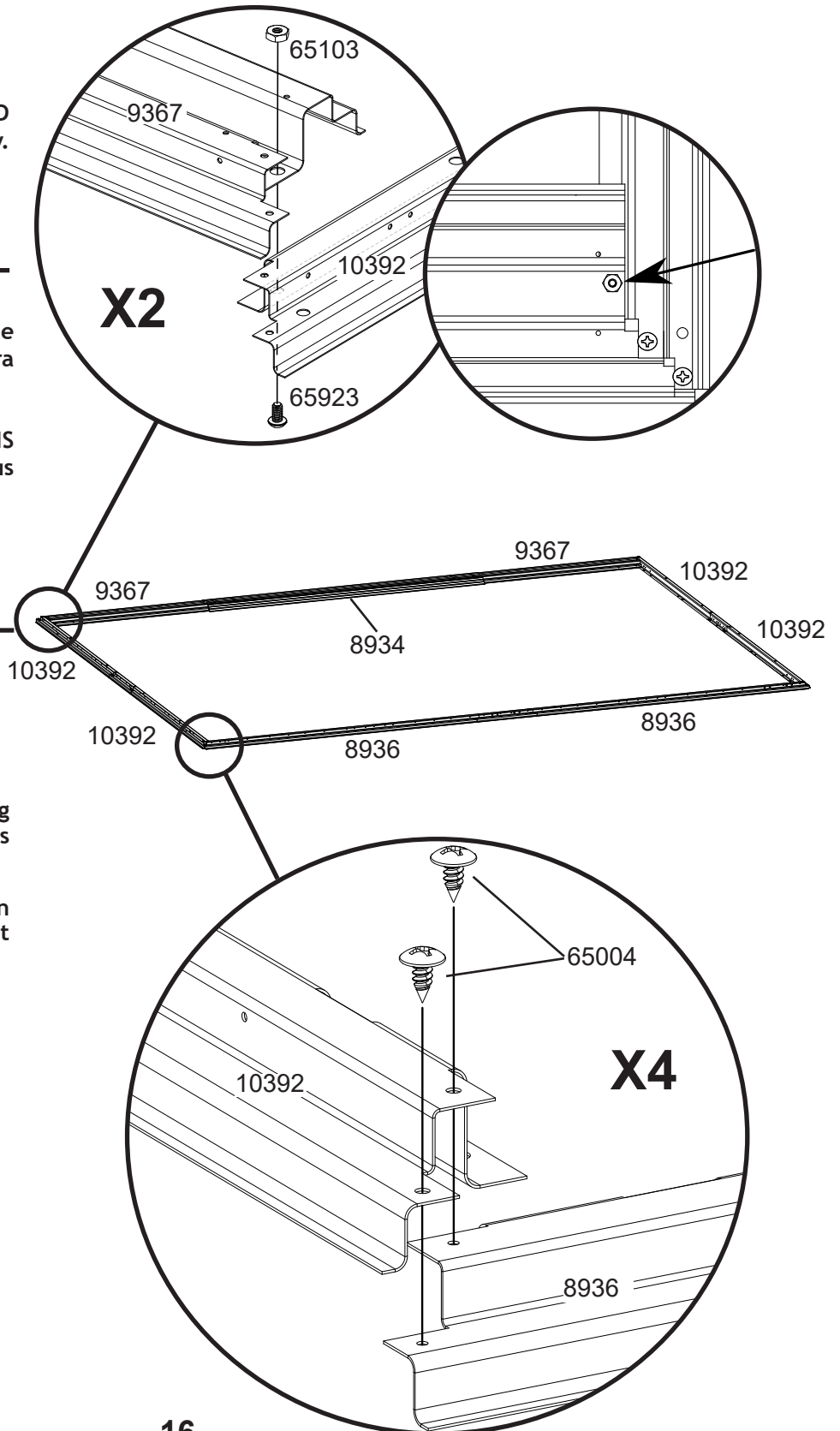



# 2: PRE-ASSEMBLY

PRÉ-ASSEMBLAGE  
VORMONTAGE

EN,FR,GE-171C

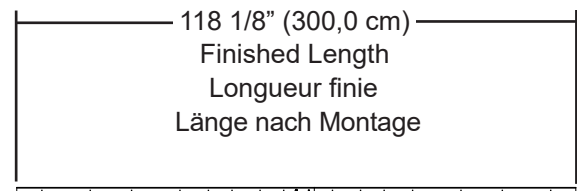
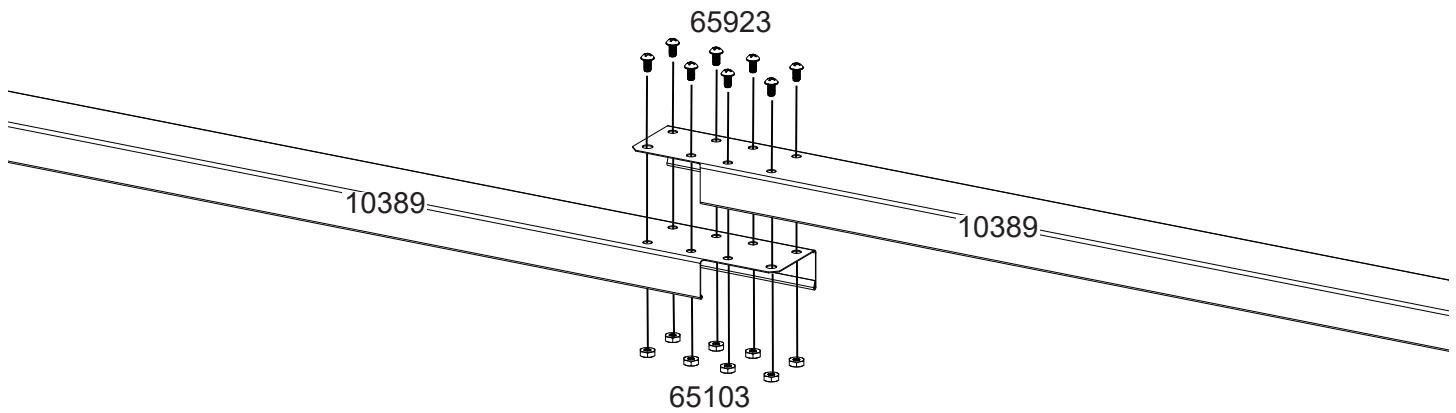
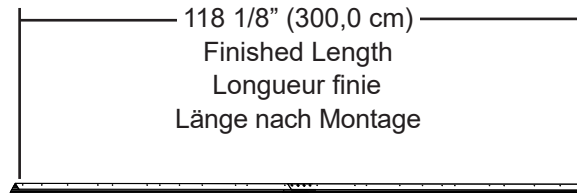
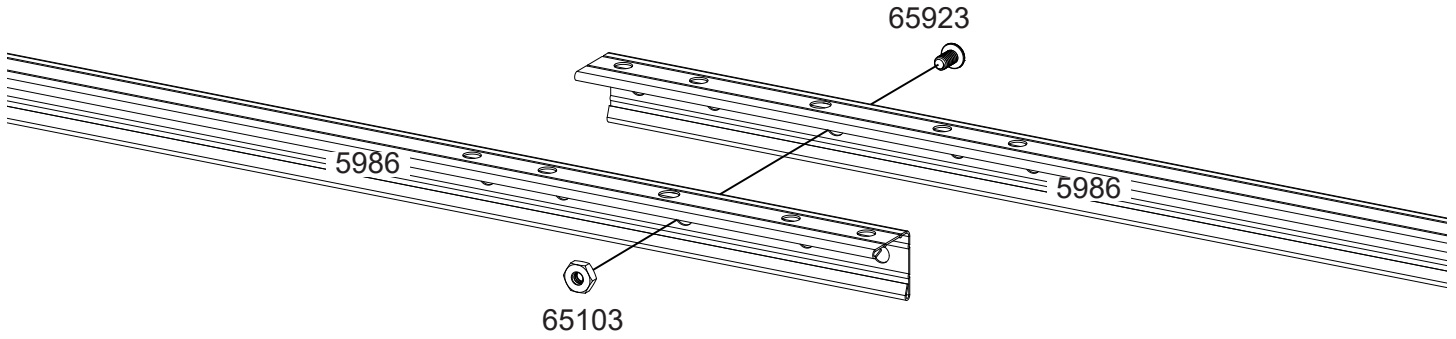
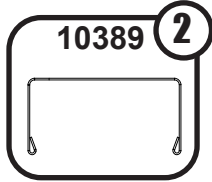
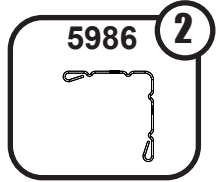
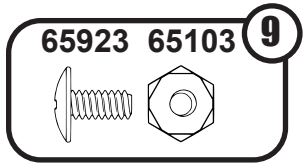

# 2: PRE-ASSEMBLY

PRÉ-ASSEMBLAGE  
VORMONTAGE

EN,FR,GE-18IC

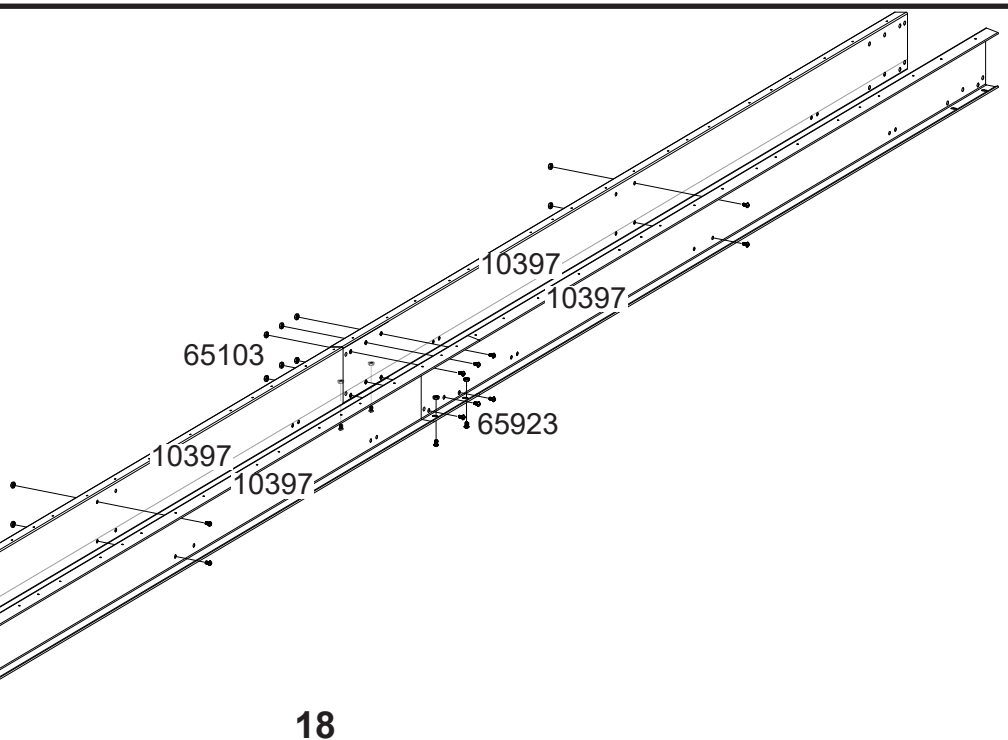
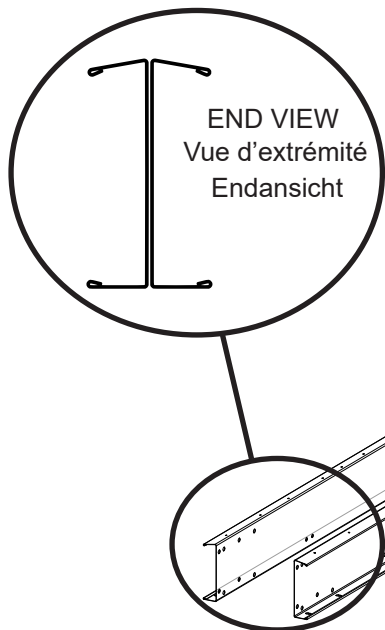
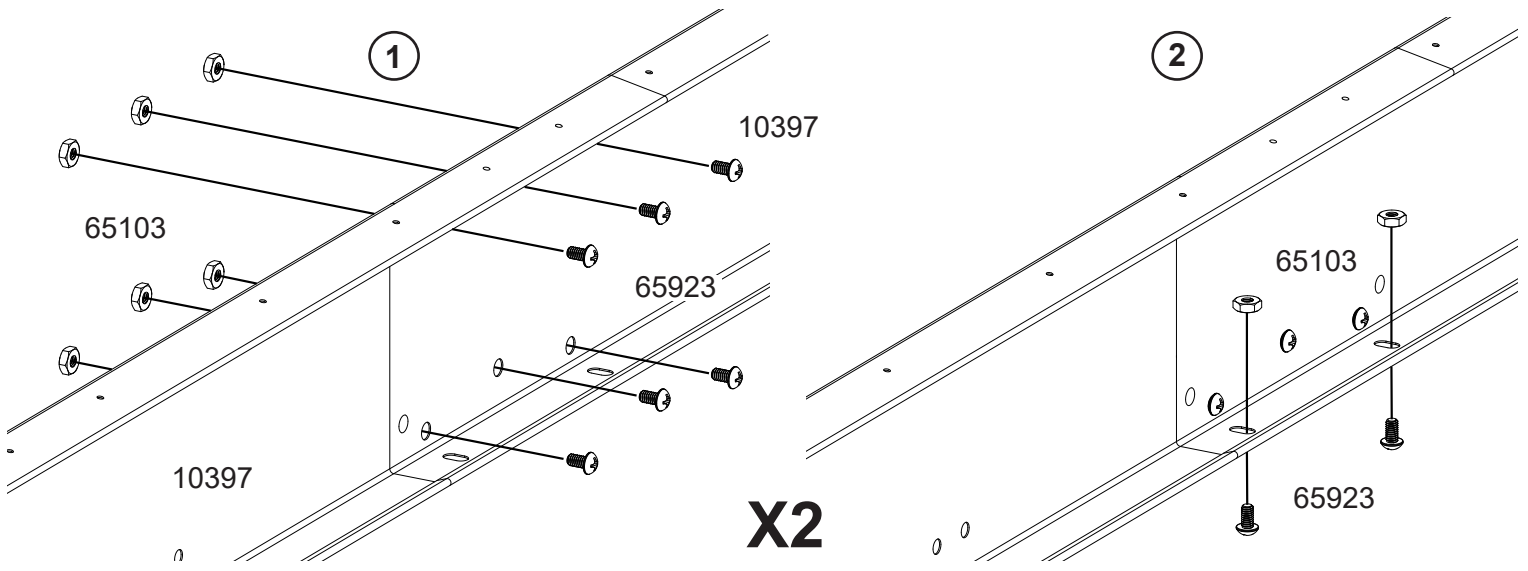
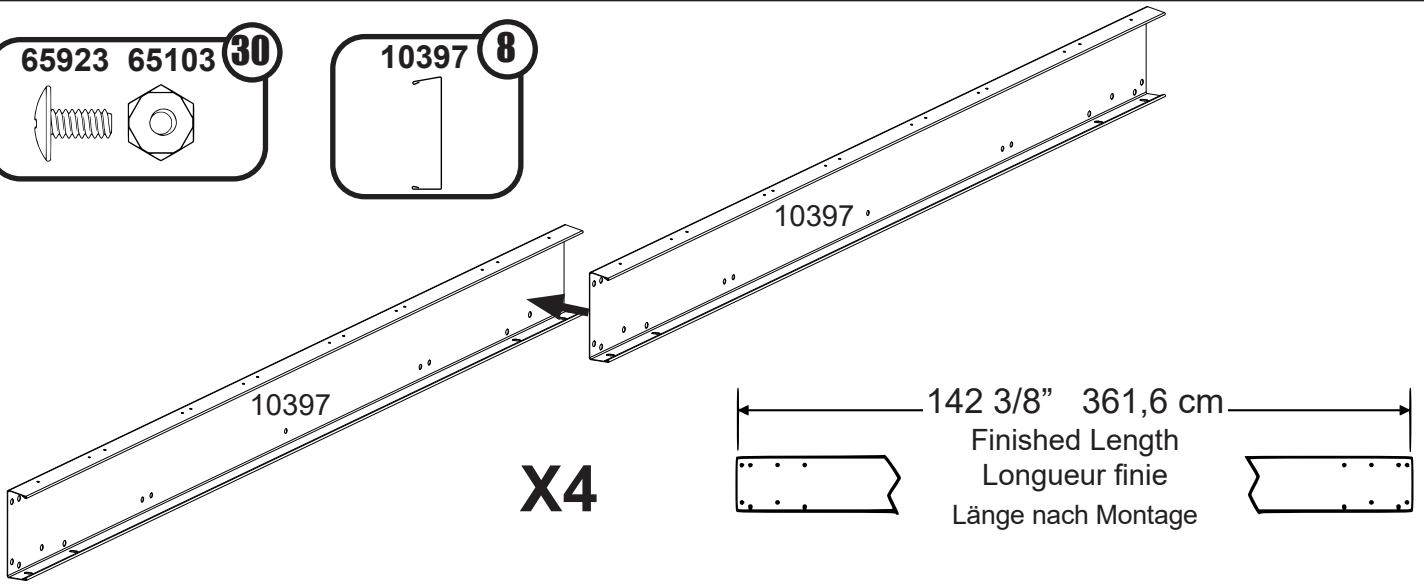
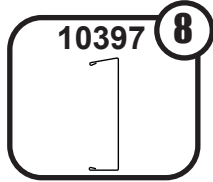
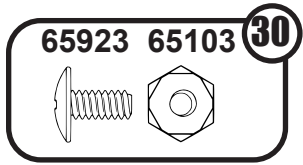

# 2: PRE-ASSEMBLY

PRÉ-ASSEMBLAGE  
VORMONTAGE

EN,FR,GE-19IB

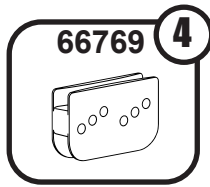
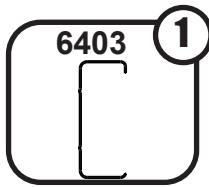
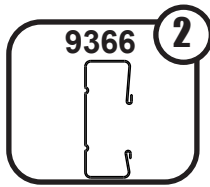
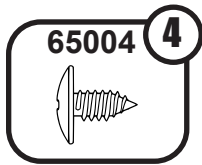

6403  
**Painted Part**  
**Partie Peinte**  
**Lackierte Teil**

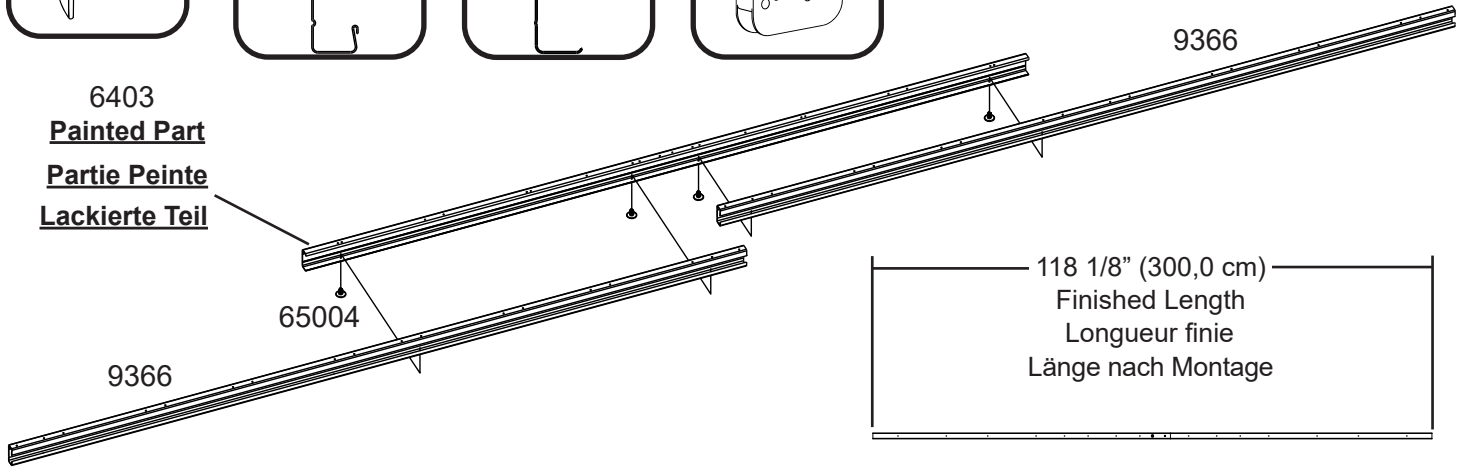

118 1/8" (300,0 cm)  
Finished Length  
Longueur finie  
Länge nach Montage

END VIEW  
PROFIL  
ENDANSICHT

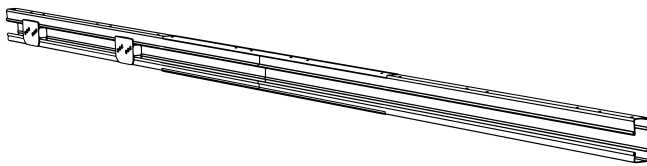

CORRECT  
CORRECTO  
KORREKT

Long Leg  
on top.  
Aile longue en  
haut  
Langer  
Schenkel oben

INCORRECT  
INCORRECTO  
FALSCH

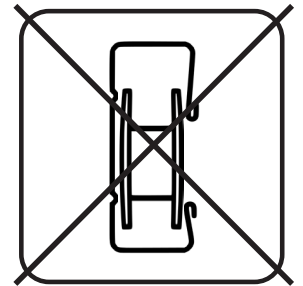

Door Slide  
Coulisseau  
de porte  
Türgleiter

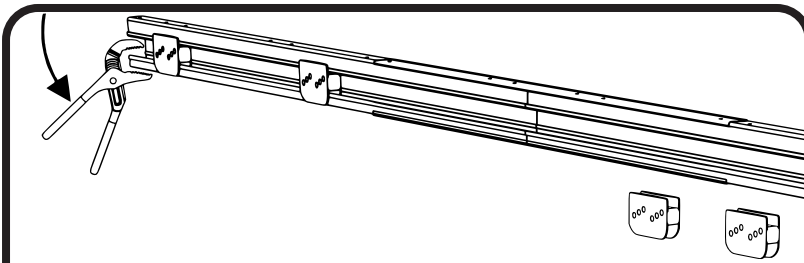

Slides should be installed in Door Track prior to installation. However, if this step is overlooked or if the Slides need to be removed for maintenance, the following procedure may be used.

Les coulisseaux doivent être placés dans le rail de porte avant la pose du rail. Toutefois, si cette étape est omise ou si les coulisseaux doivent être déposés à des fins d'entretien, la méthode suivante peut être utilisée.

Die Schlitten sollten vor dem Einbau in der Türschiene montiert werden. Falls dieser Schritt ausgelassen wird oder die Schlitten für Wartungsarbeiten entfernt werden müssen, geht man wie folgt vor.

### To remove or install Door Slides:

- Remove Doors from Slides and set aside.
- Using pliers, bend down a corner of the Door Track.
- Remove or install Door Slides.
- Carefully bend the corner back into position.

### Türschlitten Entfernen oder Einbauen:

- Türe der Schlitten entfernen und beiseite stellen.
- Mit einer Zange eine Ecke der Türschiene nach unten biegen.
- Türschlitten entfernen oder einbauen.
- Die Ecke vorsichtig zurück an ihren Platz biegen.

### Pour déposer ou poser les coulisseaux de porte :

- Détacher les portes des coulisseaux et les mettre de côté.
- Avec une pince, rabattre un coin du rail de porte.
- Retirer ou enfiler les coulisseaux de porte.
- Avec précaution, remettre le coin du rail dans sa position d'origine.

# 2: PRE-ASSEMBLY

PRÉ-ASSEMBLAGE  
VORMONTAGE

EN,FR,GE-201C

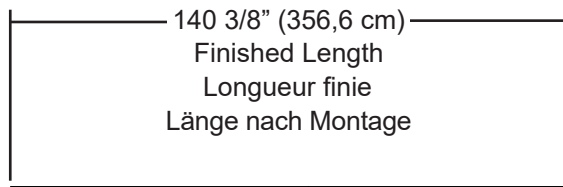
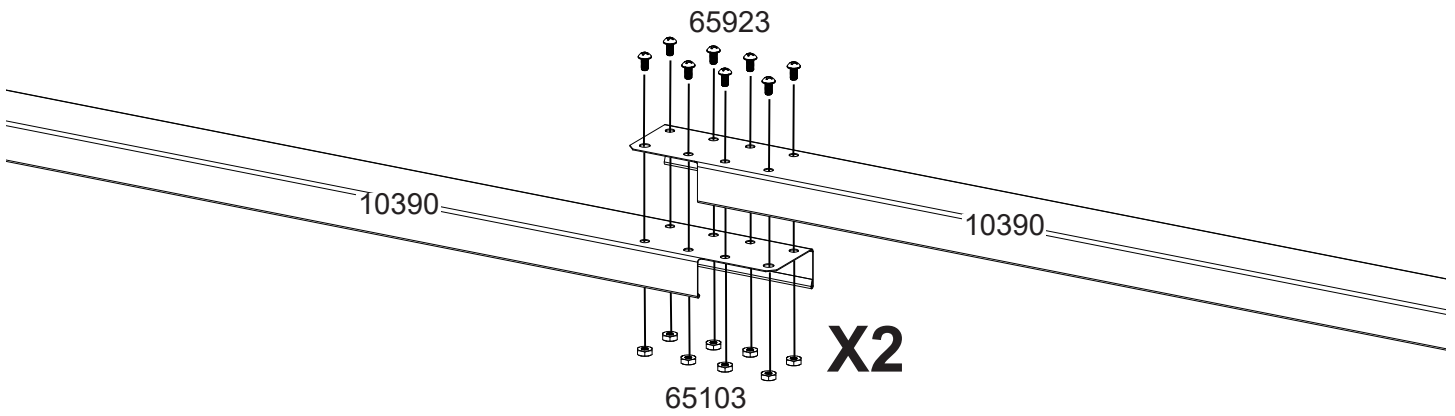
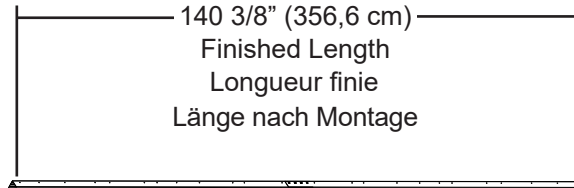
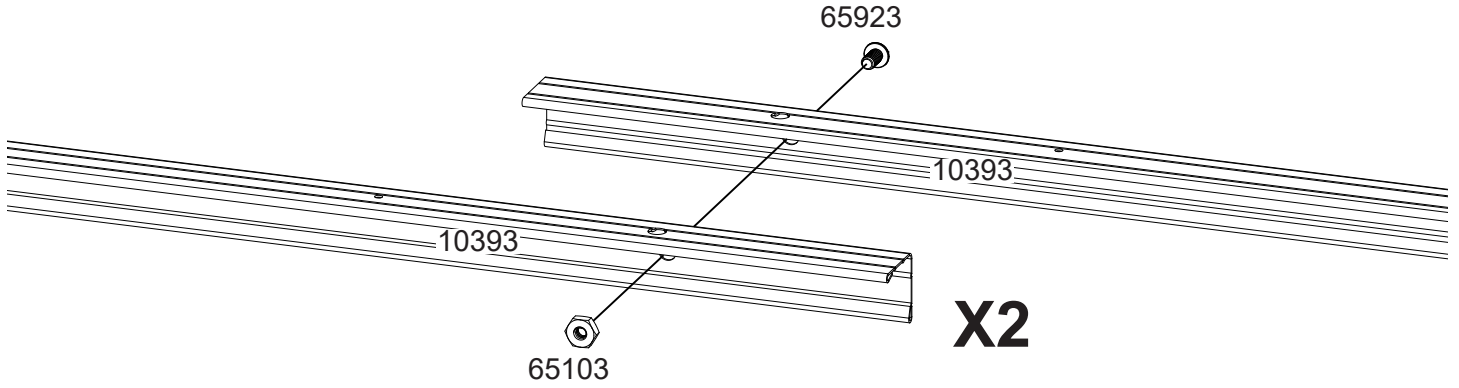
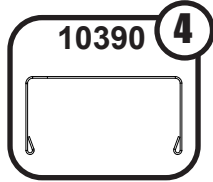
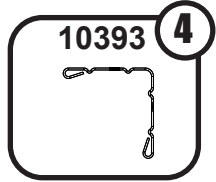
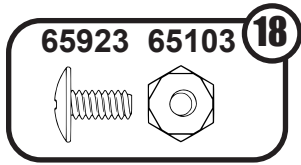

# 3: CORNER PANELS

PANNEAUX D'ANGLE  
ECKPLATTEN

EN,FR,GE-21LN

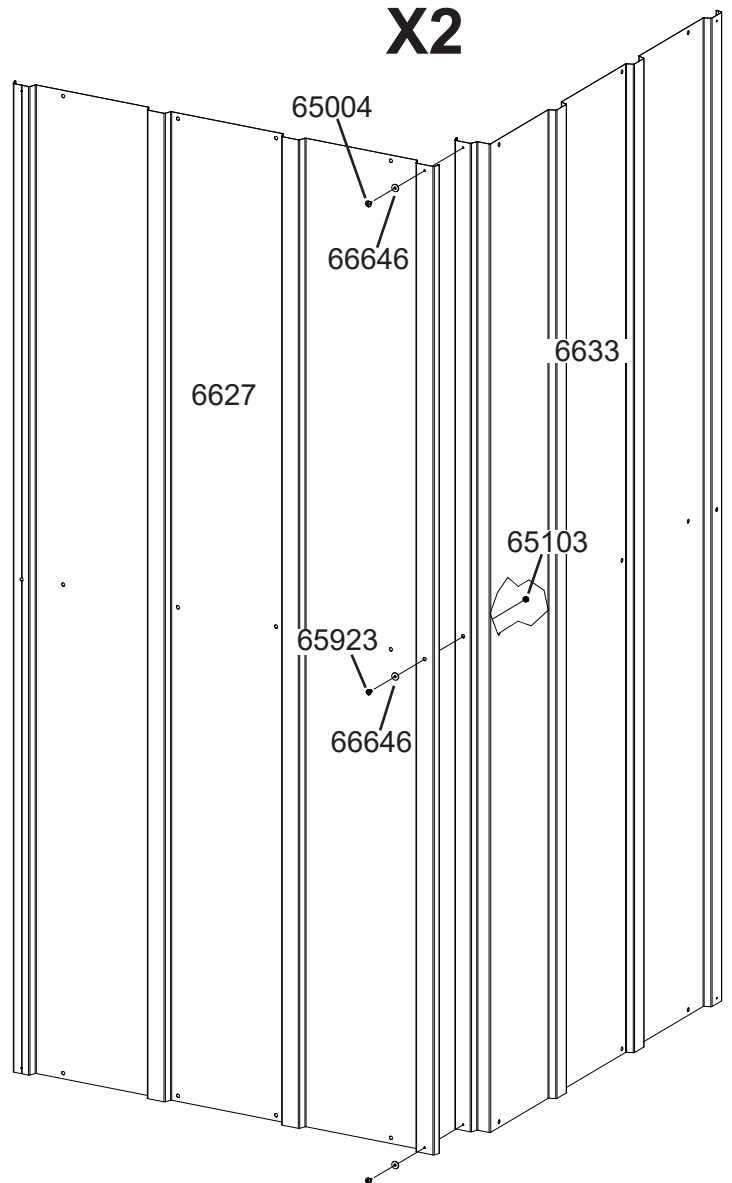
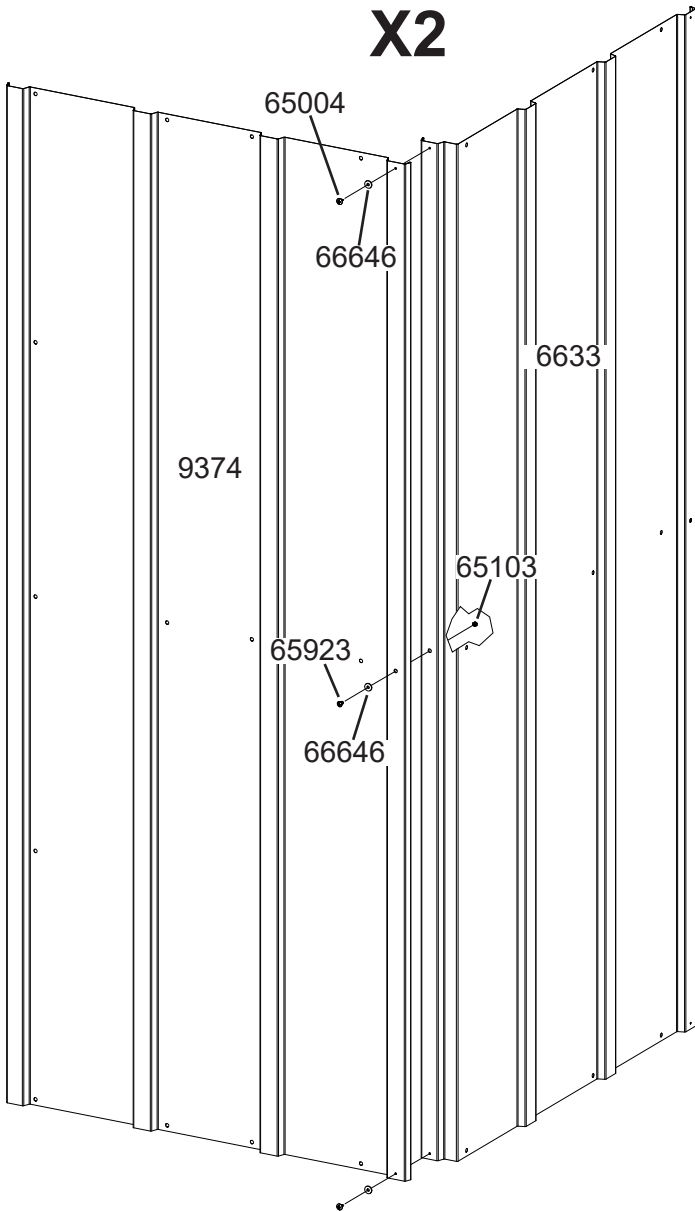
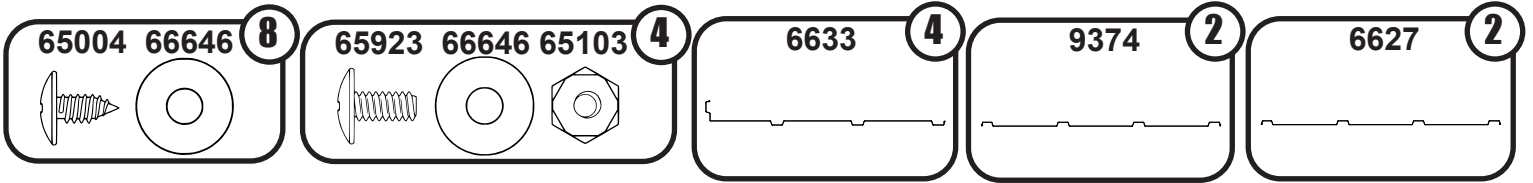

# 3: CORNER PANELS

PANNEAUX D'ANGLE  
ECKPLATTEN

EN,FR,GE-22LO

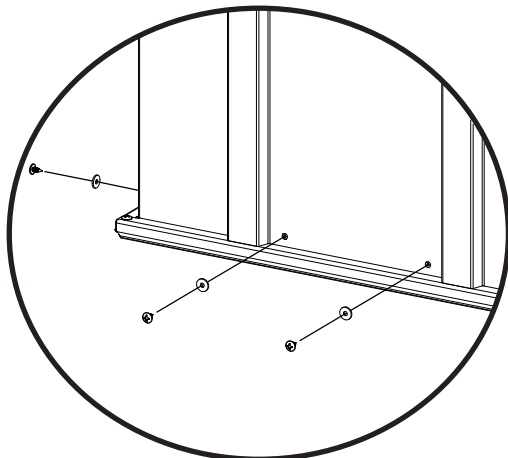
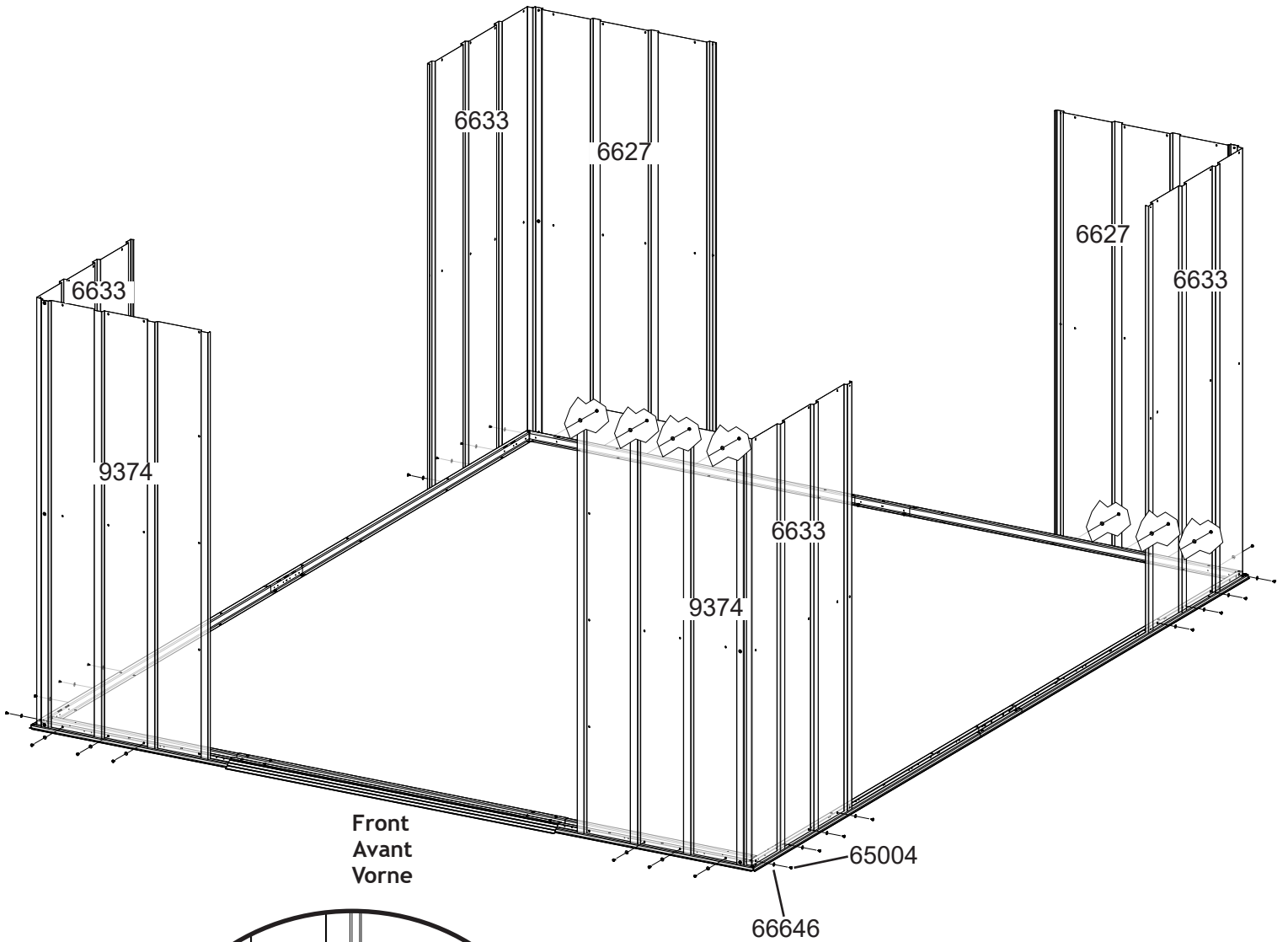
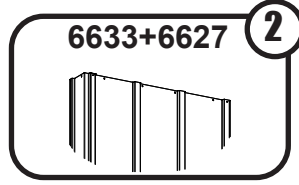
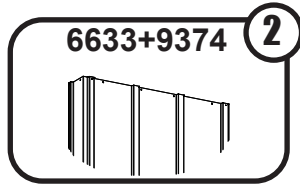
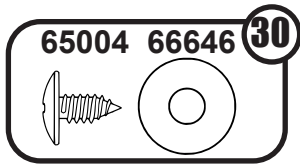

# 4: WALL ANGLE *CORNIÈRE DE MUR* *WANDWINKEL*

EN,FR,GE-23IC

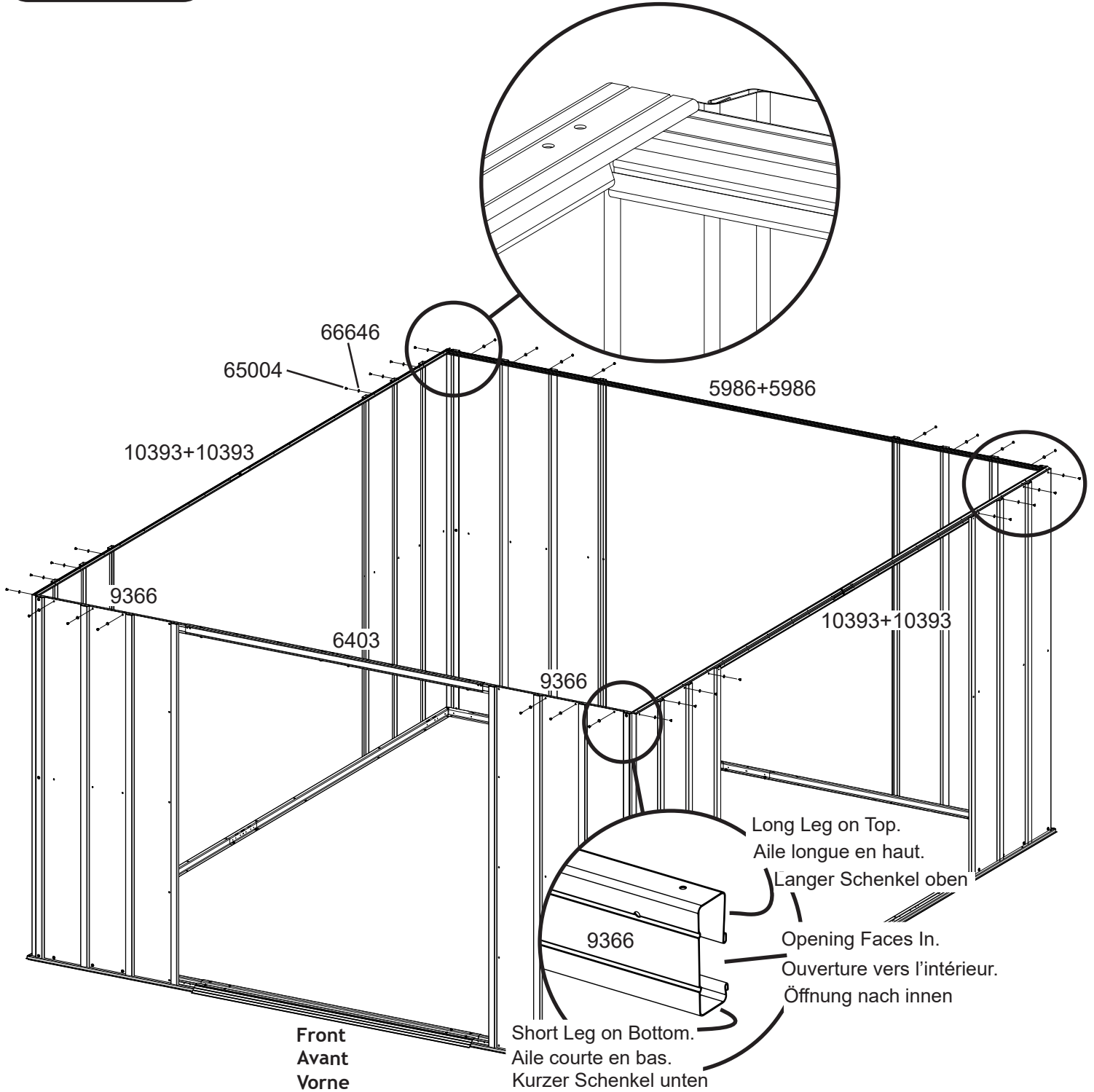
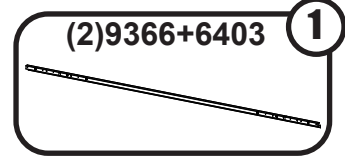
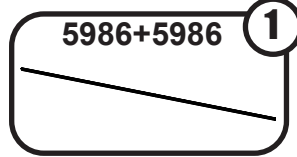
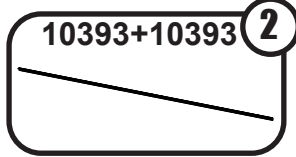
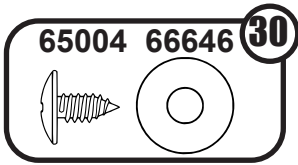

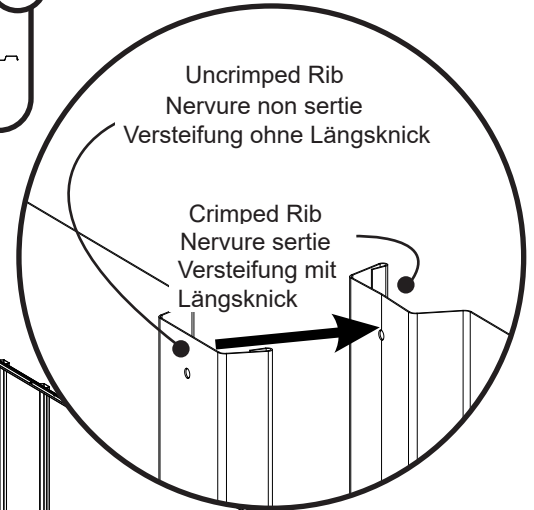
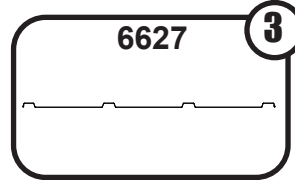
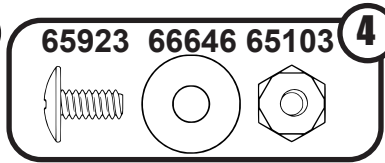
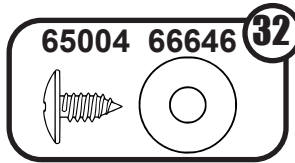

Whenever a crimped rib and an uncrimped rib meet, the crimped rib should be placed **UNDER** the uncrimped rib if possible.

Lors de l'assemblage de toute nervure sertie avec une nervure non sertie, la nervure sertie doit être placée **SOUS** la nervure non sertie autant que possible.

Immer dann, wenn eine Versteifung mit Längsknick an eine Versteifung ohne Längsknick stößt, sollte die Versteifung mit Längsknick falls möglich **UNTER** der Versteifung ohne Längsknick montiert werden.

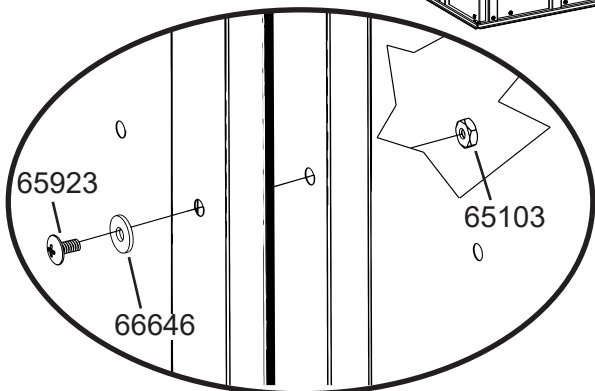
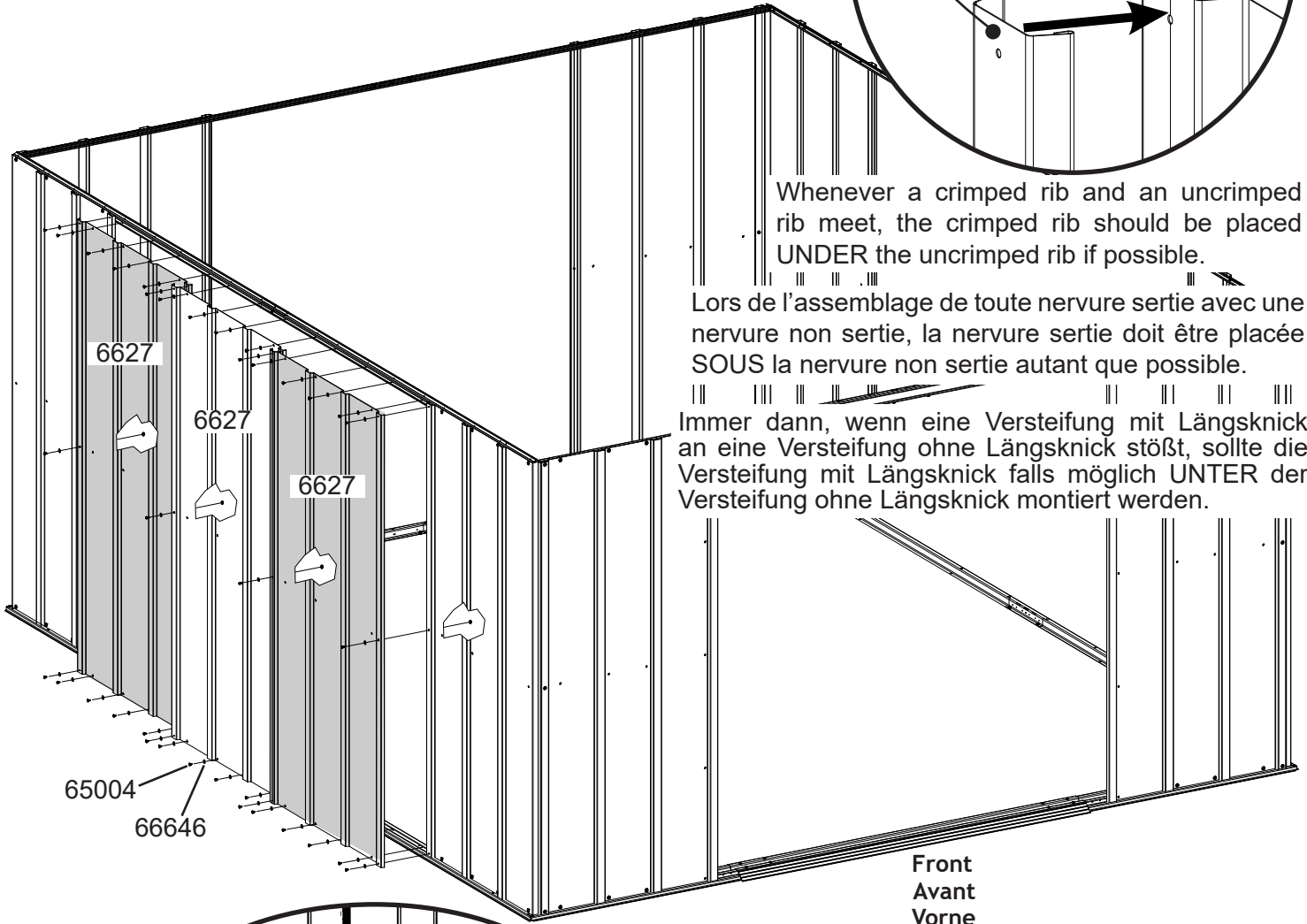



# 5: WALL PANELS

PANNEAUX DE MUR  
WANDBLECHE

EN,FR,GE-25LO

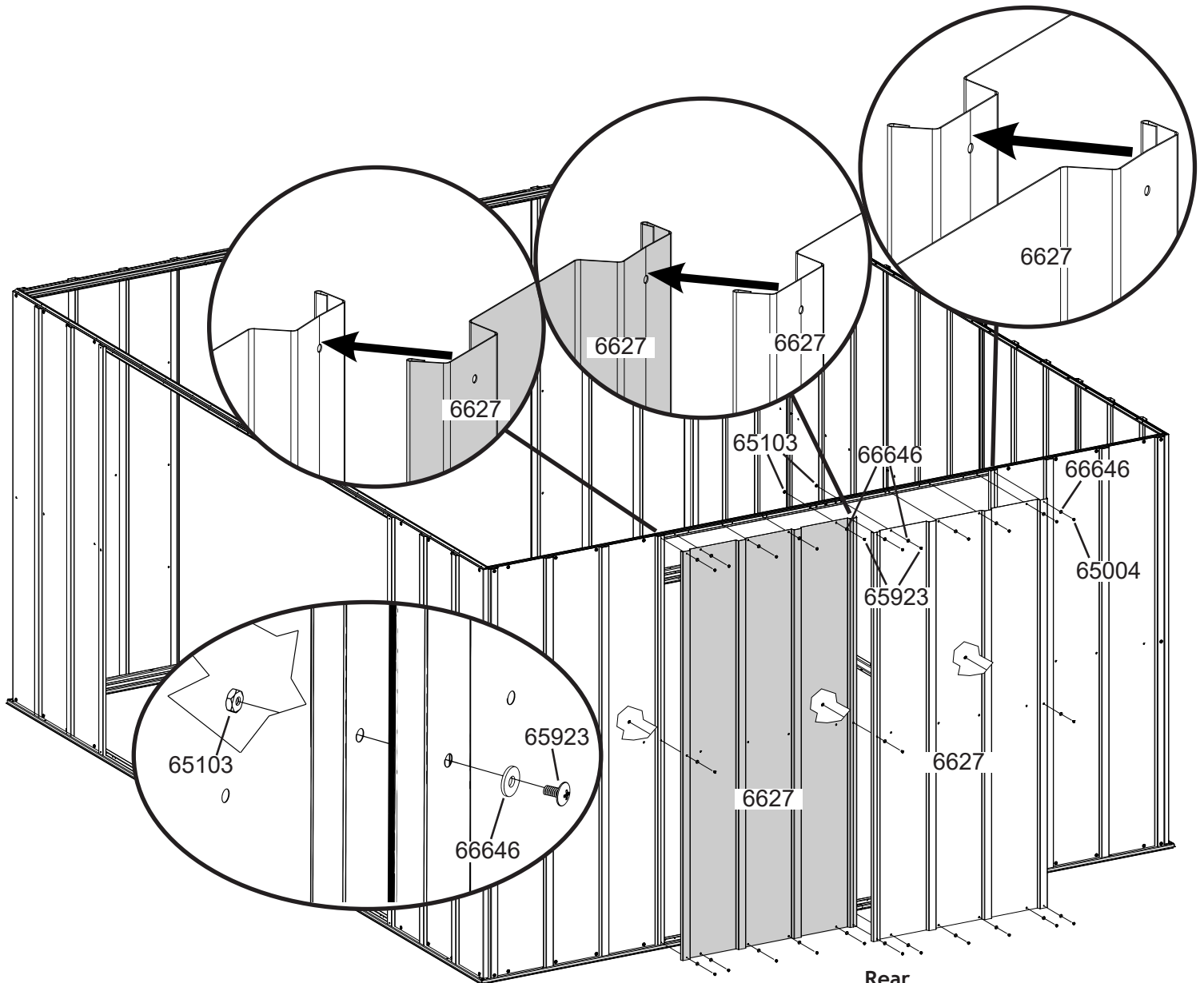
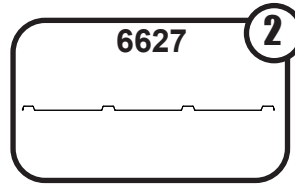
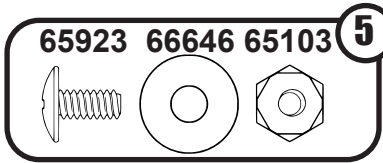
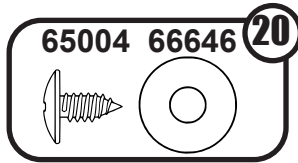

Rear  
Arrière  
Hinten

# 5: WALL PANELS

PANNEAUX DE MUR  
WANDBLECHE

EN,FR,GE-26LO

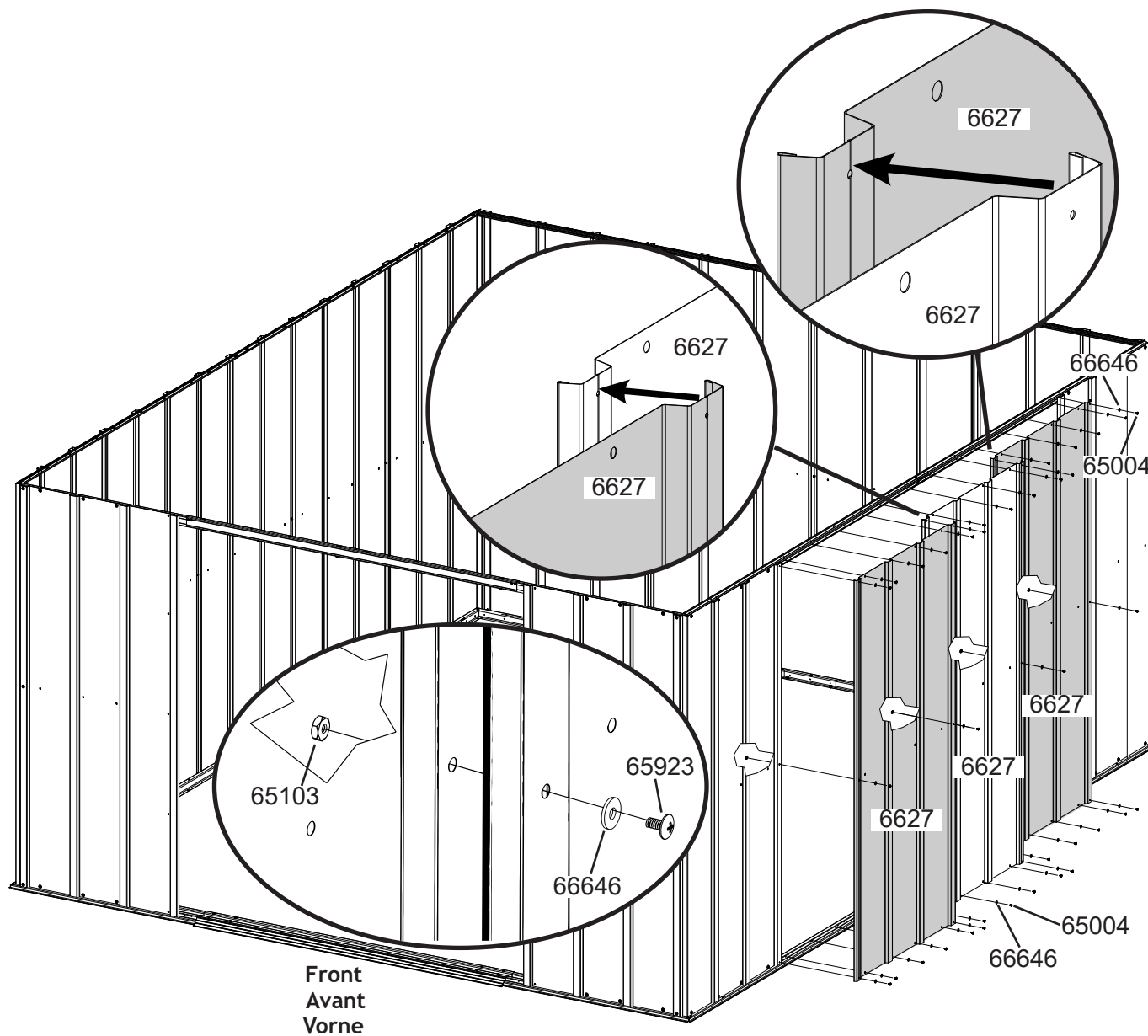
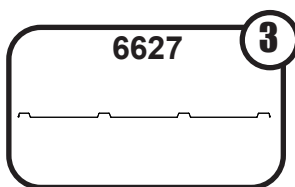
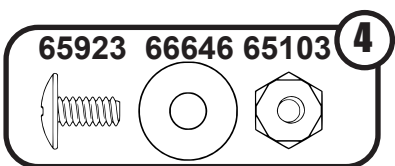
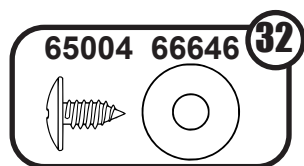

# 6: DOOR JAMB

JAMBAGE DE PORTE  
TÜRPFOSTEN

EN,FR,GE-27LO

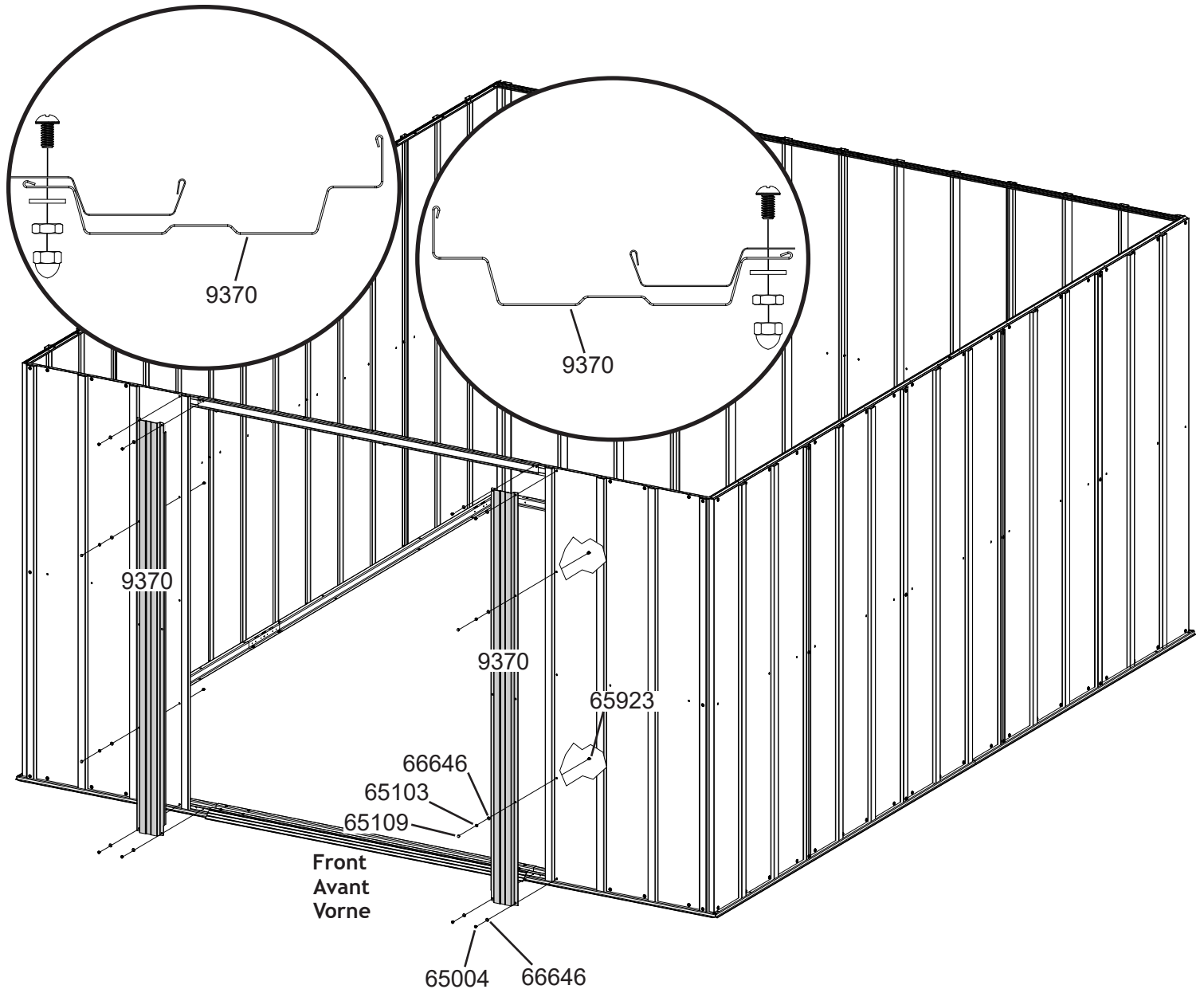
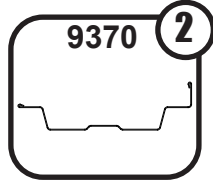
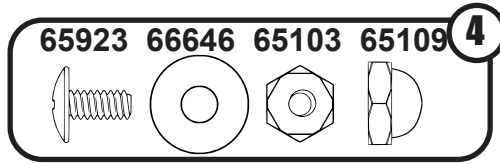
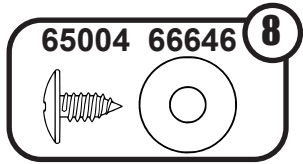

# 7: WALL CHANNEL

LONGERON DE MUR  
WAND VERSTREBUNG

EN,FR,GE-281C

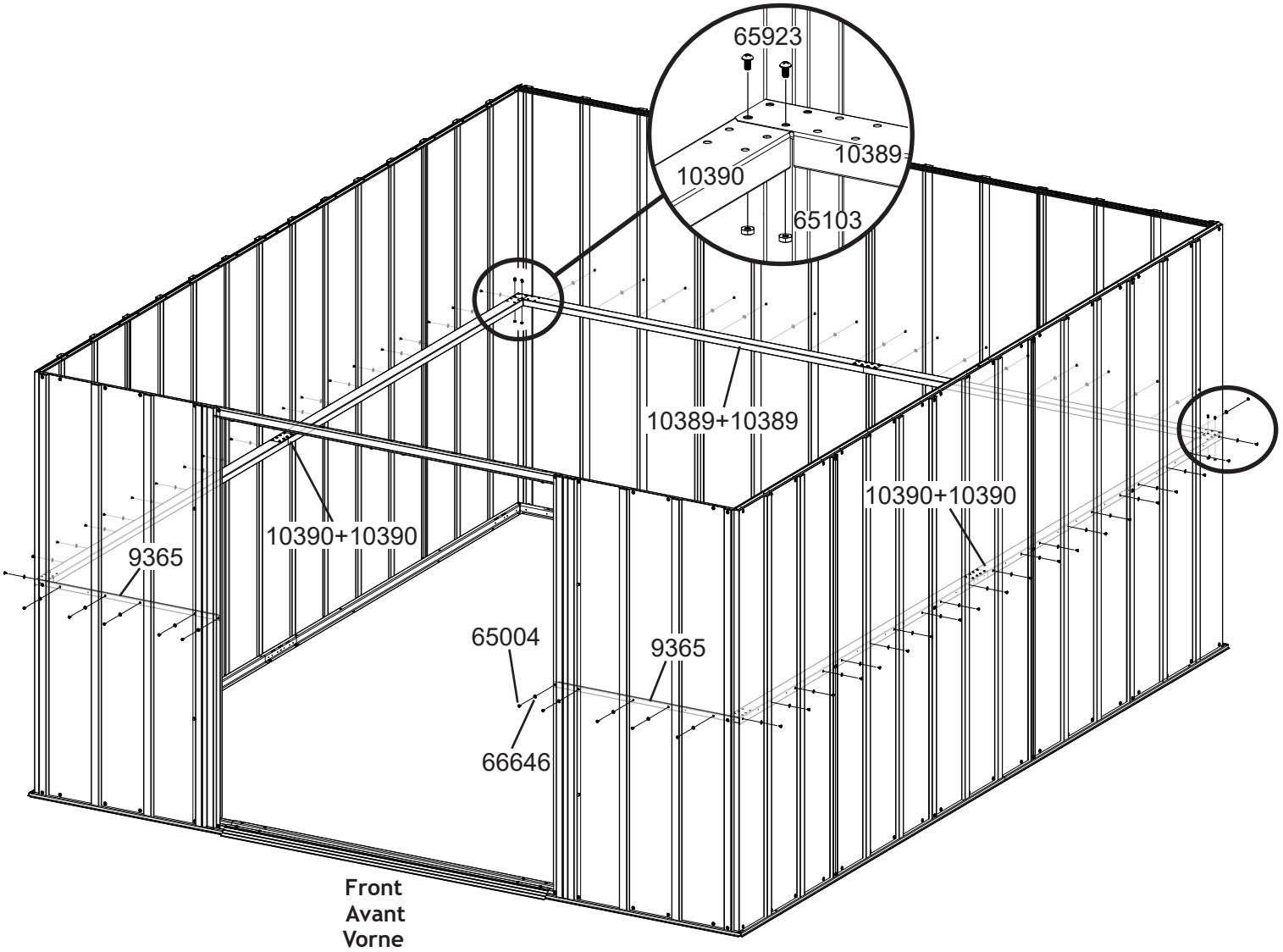
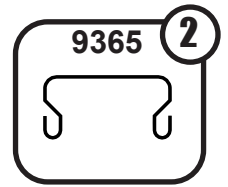
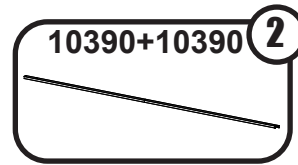
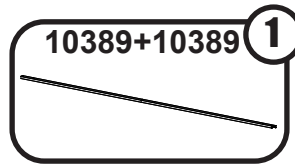
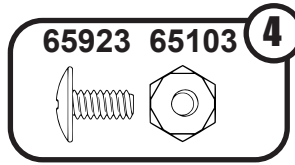
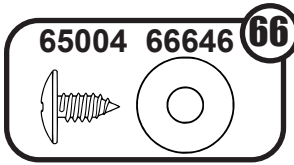

# 8: GABLES

PIGNON  
GIEBEL

EN,FR,GE-29IB

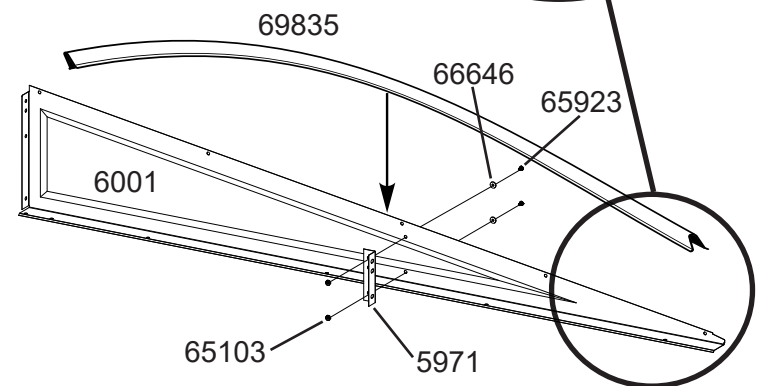
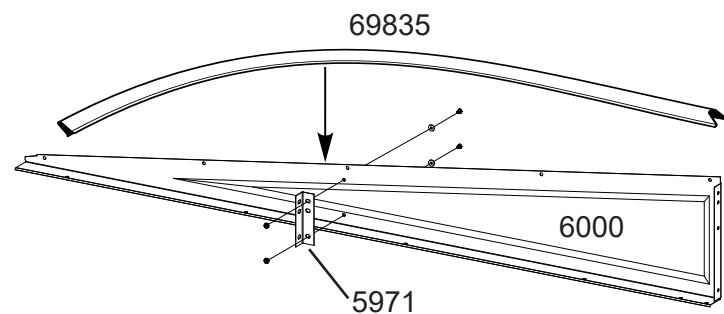
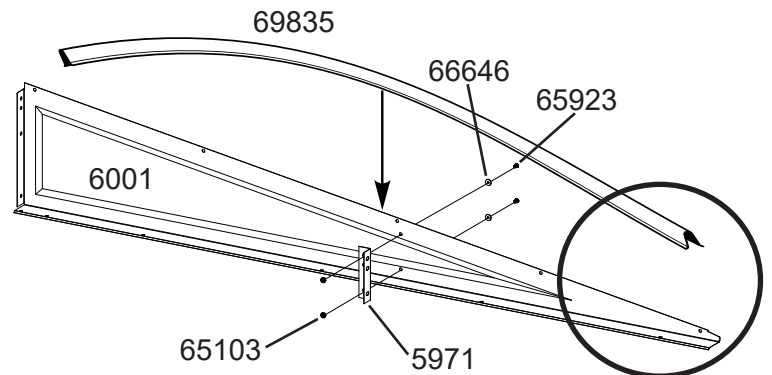
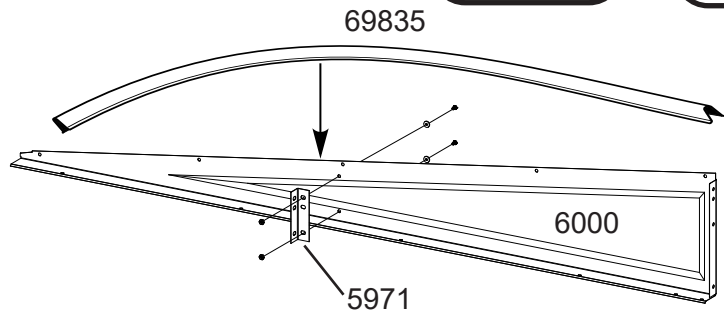
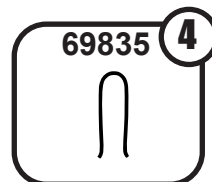
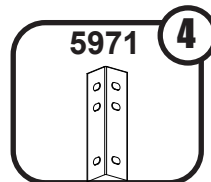
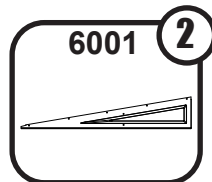
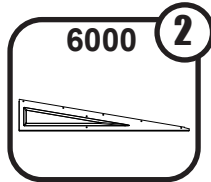
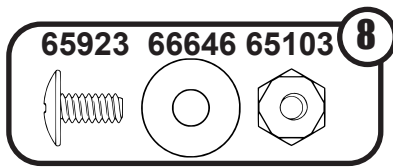

## CAUTION:

To avoid mishap on the sharp edge the edge trim must remain in place on the top edge of the gable until right and left roof panels are in place.

## PRUDENCE:

Pour éviter les accidents sur l'arête coupante de la garniture de bord, cette garniture doit rester en place sur le bord supérieur du pignon jusqu'à ce que les panneaux de toit droit et gauche soient en place.

## VORSICHT:

Um Unfälle zu vermeiden, sollte die scharfe Kante der Randleiste auf der oberen Kante des Giebels verbleiben, bis die rechten und linken Dachpaneelen angebracht sind.

# 8: GABLES

PIGNON  
GIEBEL

EN,FR,GE-30IC

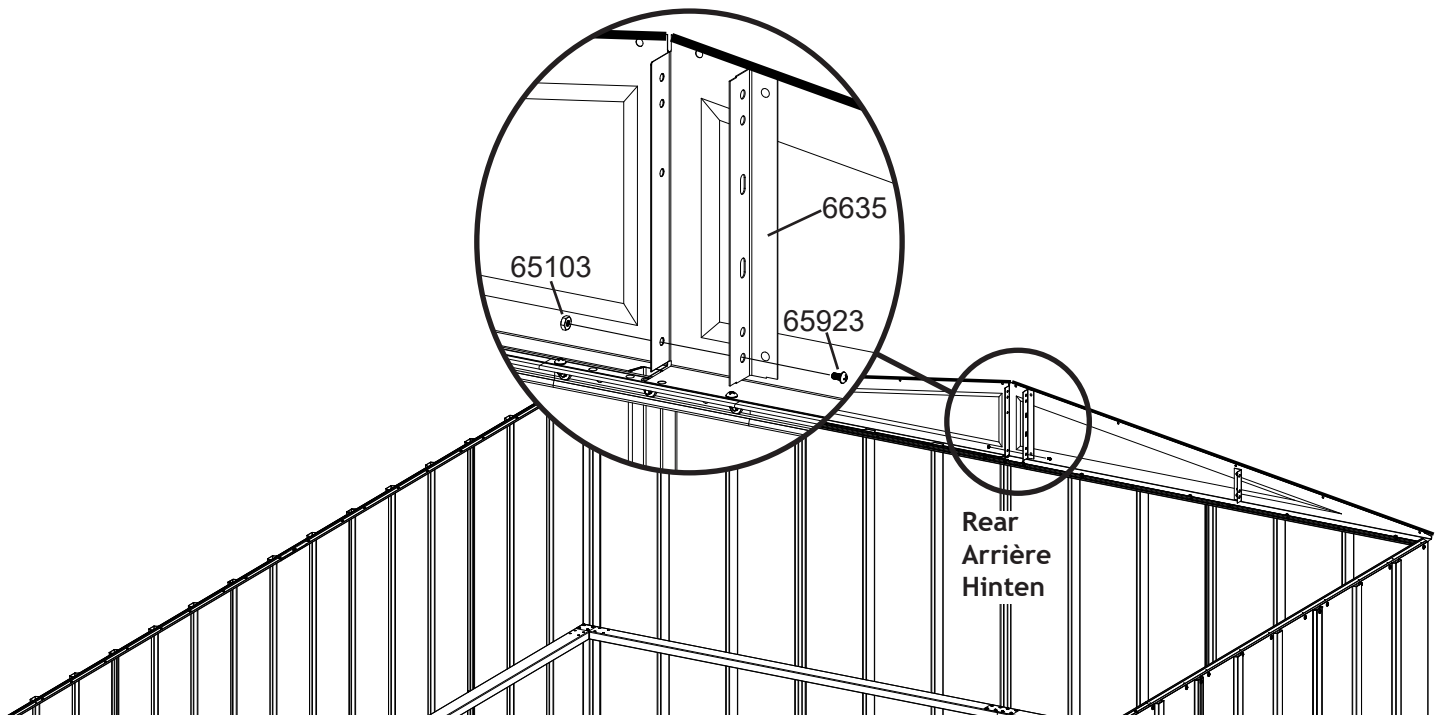
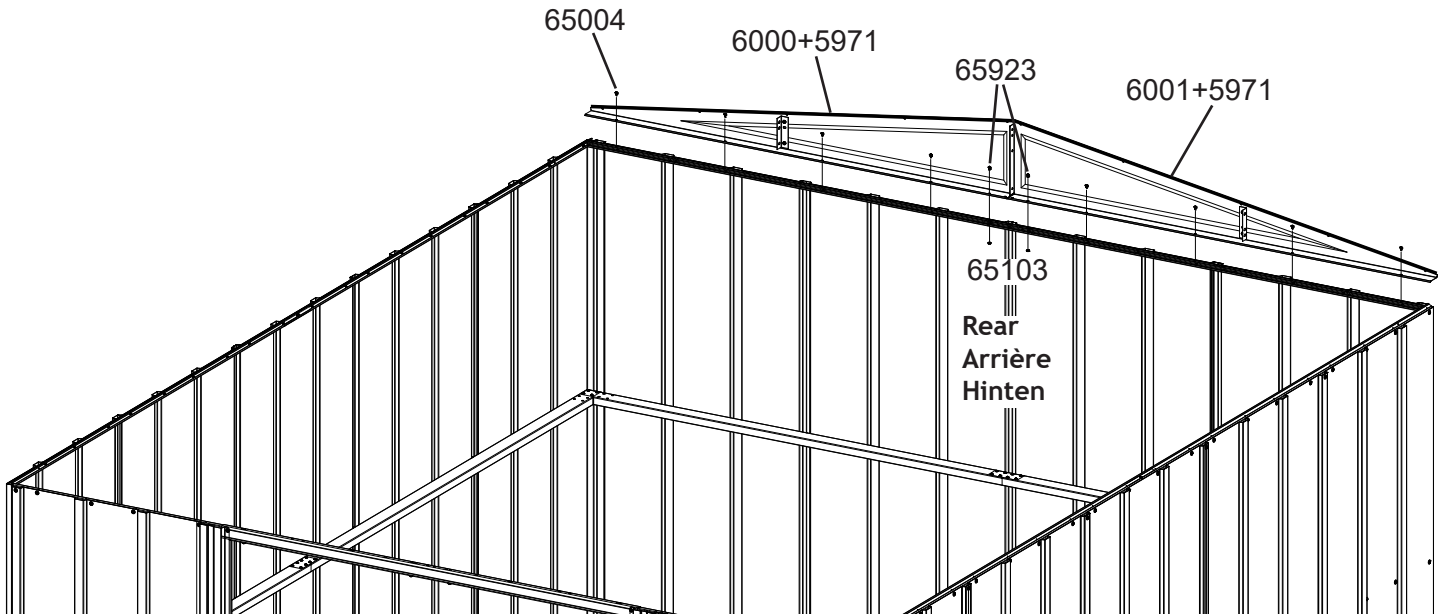
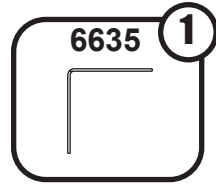
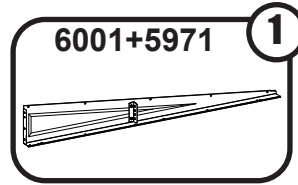
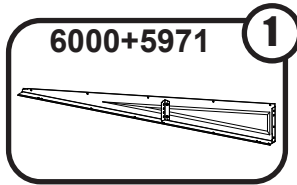
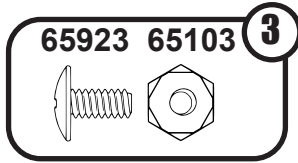
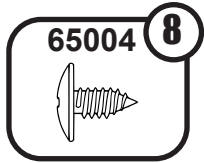

# 8: GABLES

PIGNON  
GIEBEL

EN,FR,GE-31IC

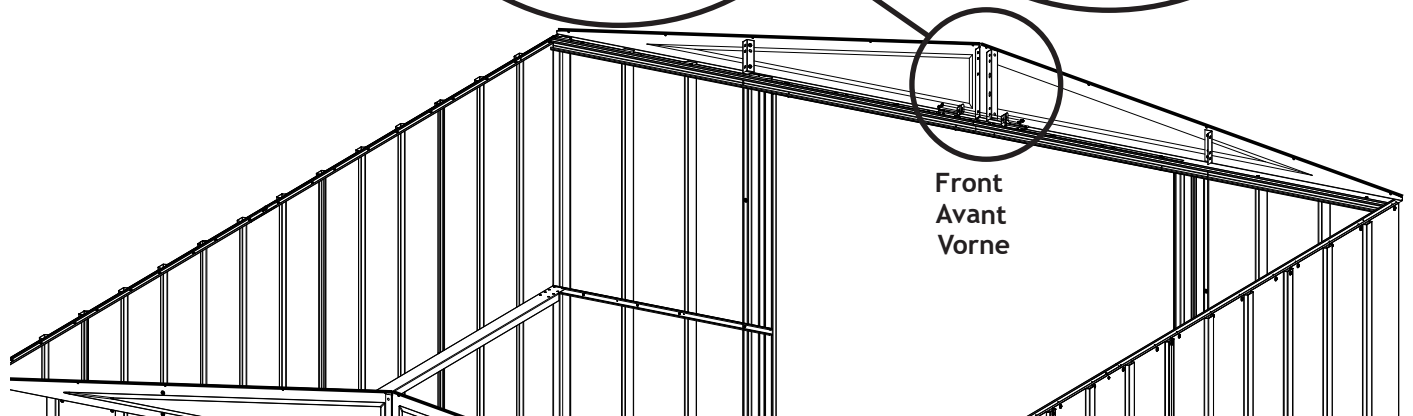
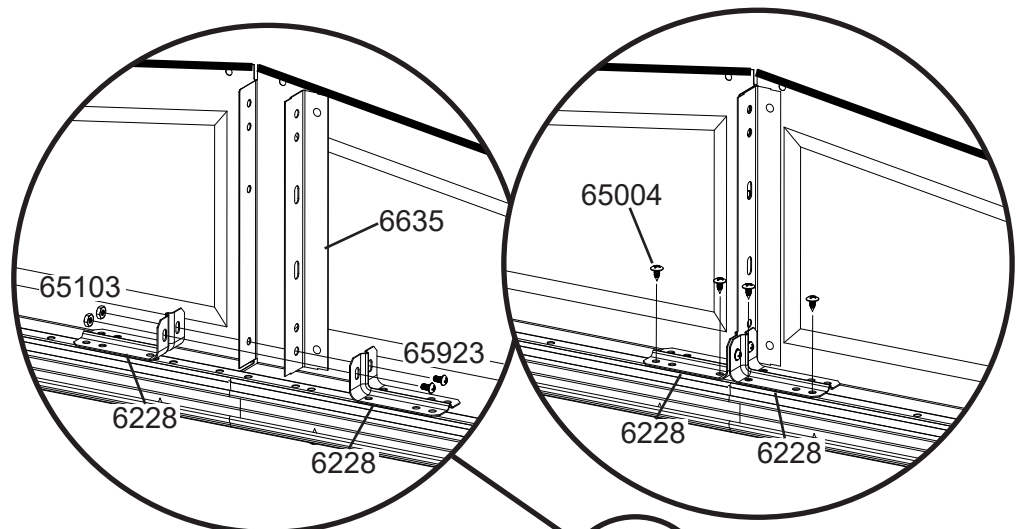
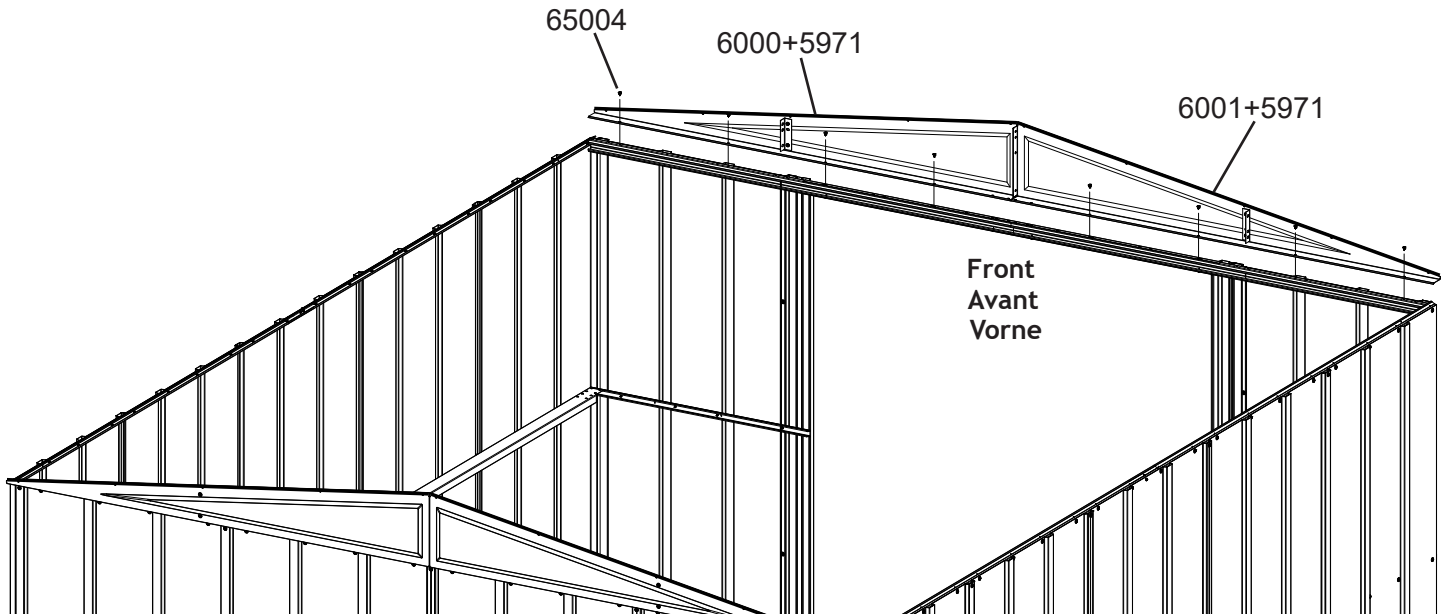
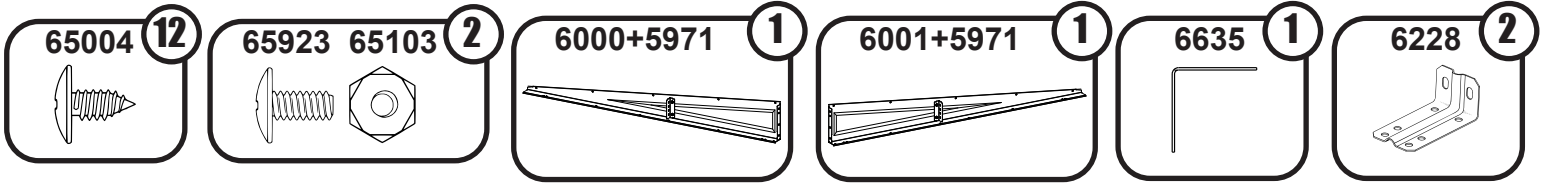

# 9: ROOF BEAMS

POUTRE DE TOIT  
DACHTRÄGER

EN,FR,GE-321C

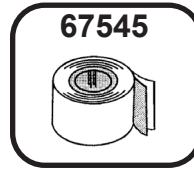
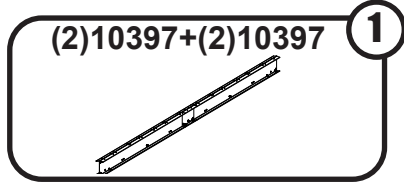
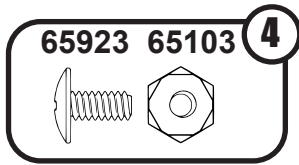

Top View of Gables  
Vue de dessus du pignon  
Draufsicht auf die Giebel

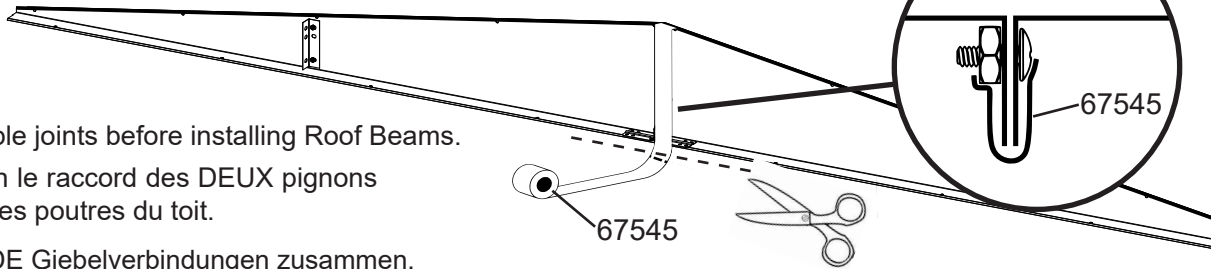

Tape BOTH Gable joints before installing Roof Beams.  
Couvrir de ruban le raccord des DEUX pignons  
avant de poser les poutres du toit.

Kleben Sie BEIDE Giebelverbindungen zusammen,  
bevor Sie die Dachbalken montieren.

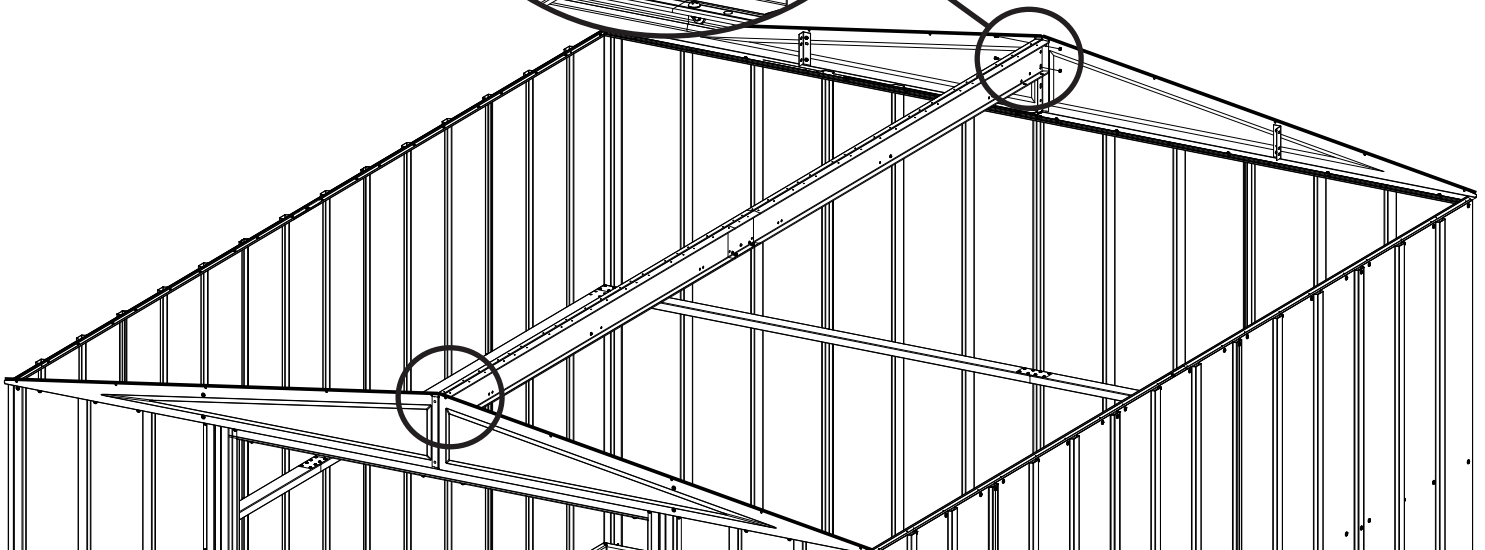
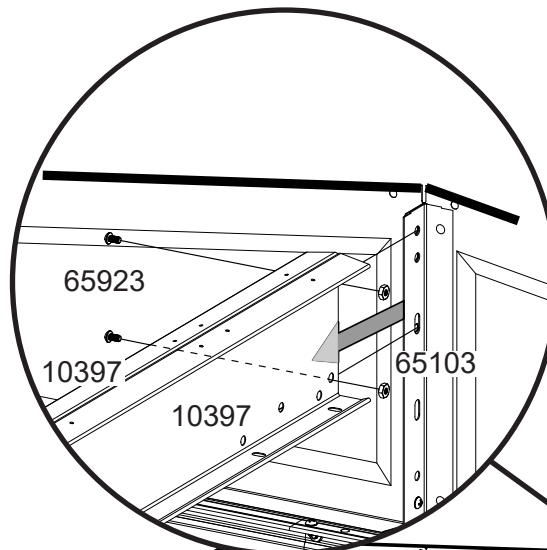



# 9: ROOF BEAMS

POUTRE DE TOIT  
DACHTRÄGER

EN,FR,GE-33IC

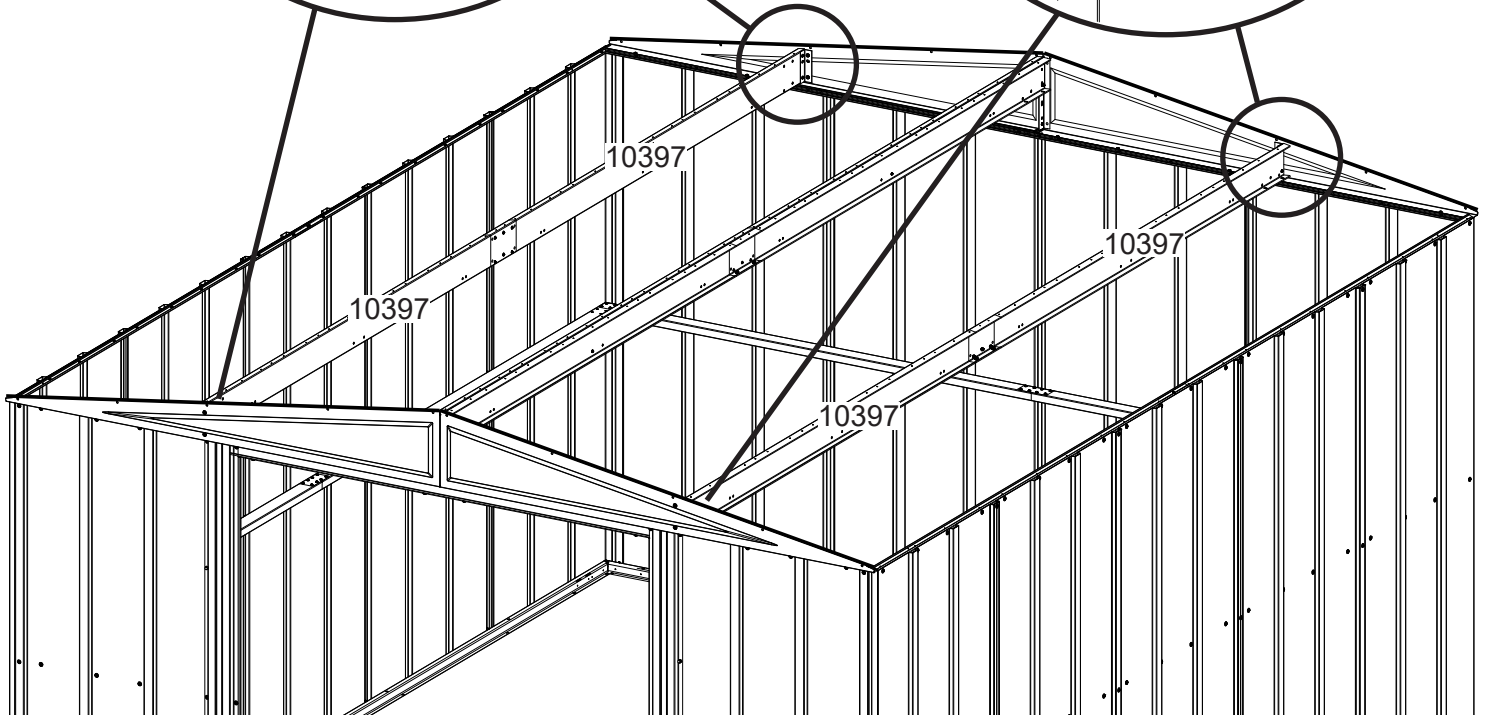
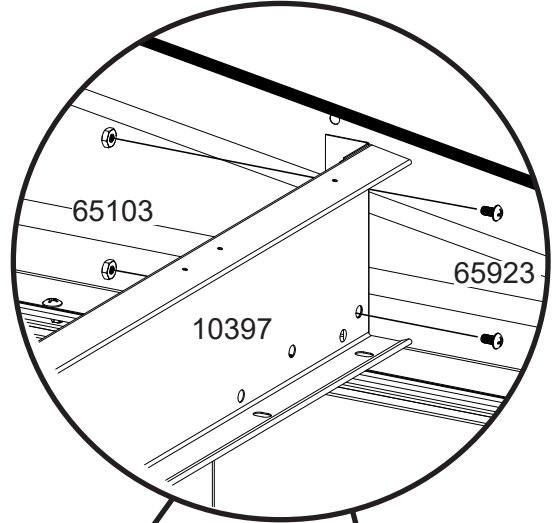
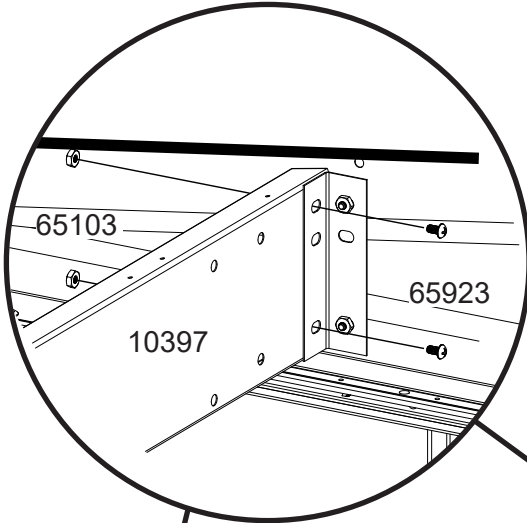
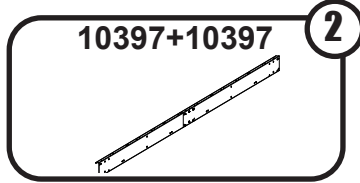
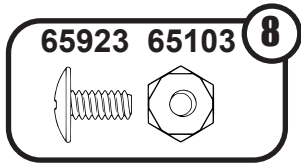

# 10: ROOF PANELS

PANNEAU DE TOIT  
DACHBLECH

EN,FR,GE-341C

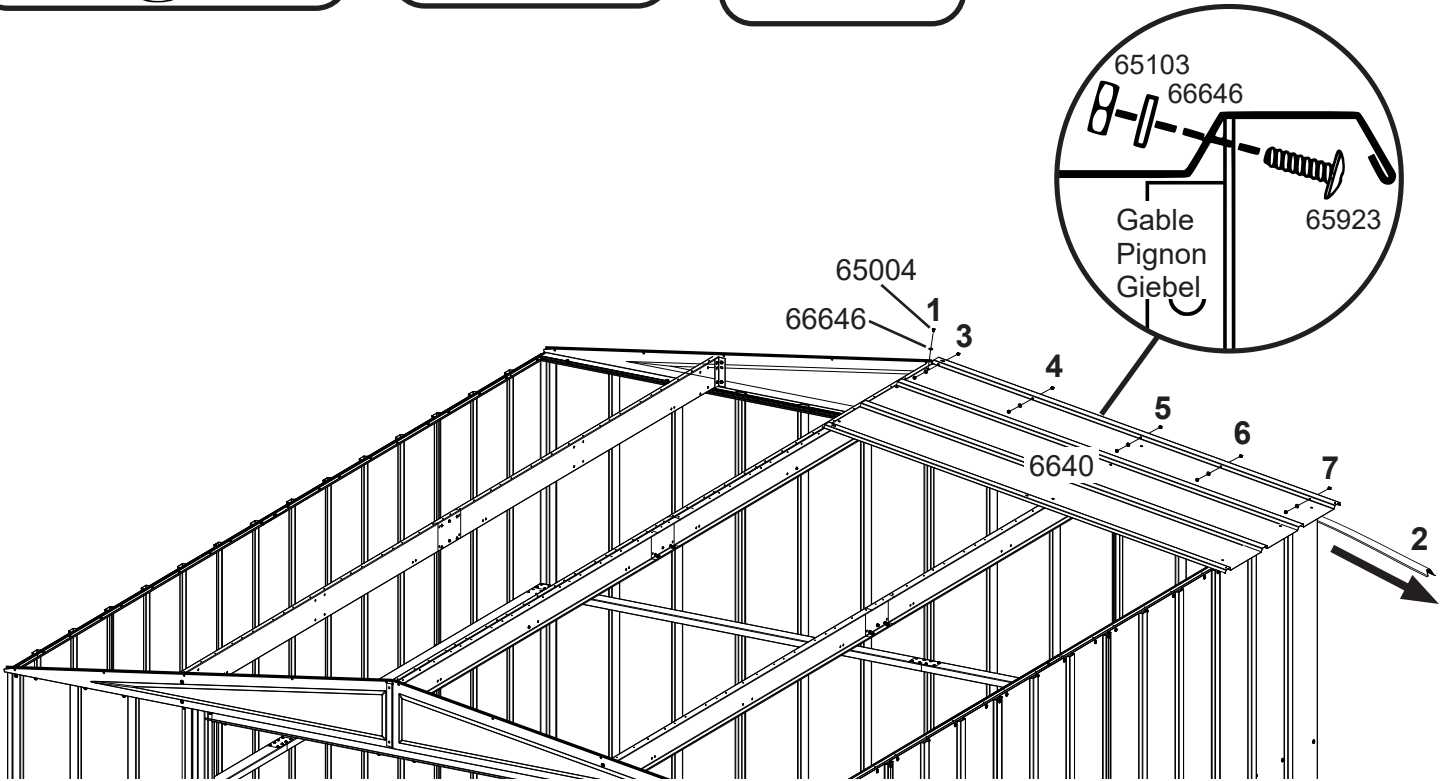
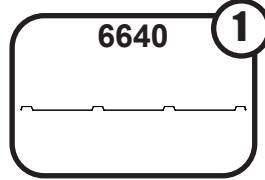
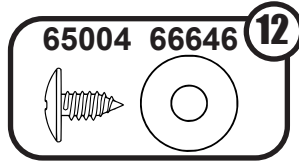
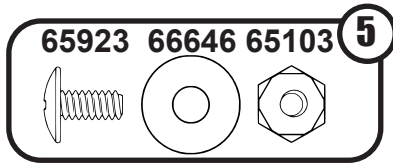

Front  
Avant  
Vorne

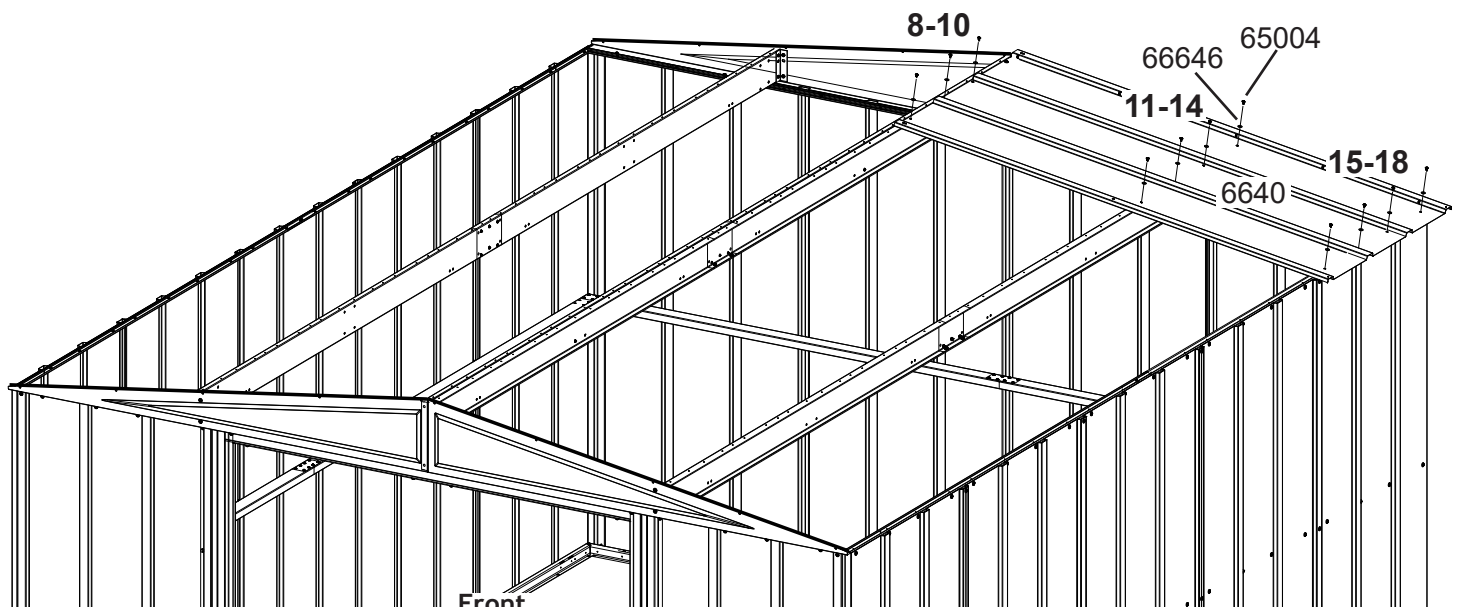

Front  
Avant  
Vorne

# 10: ROOF PANELS

PANNEAU DE TOIT  
DACHBLECH

EN,FR,GE-351C

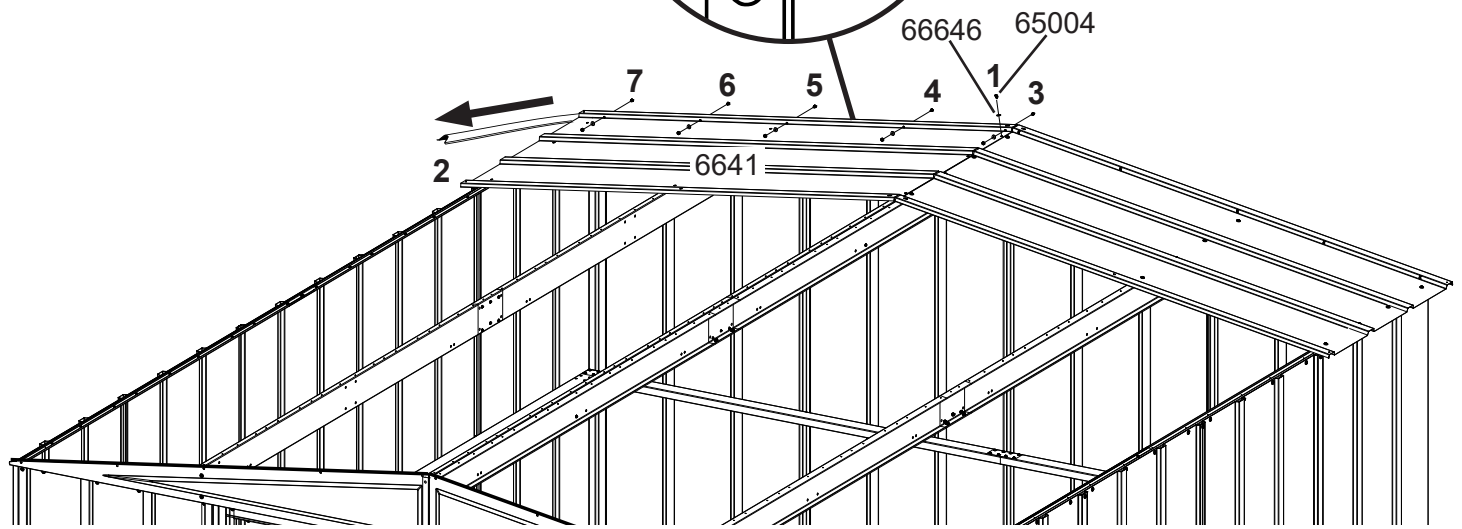
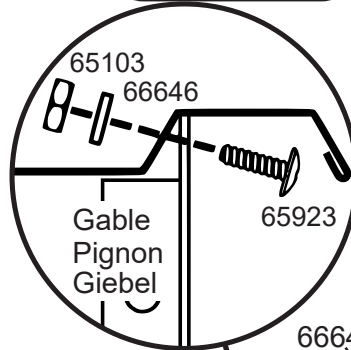
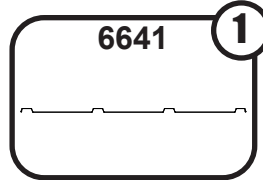
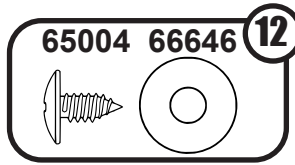
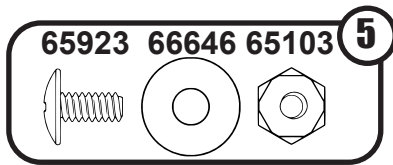

Front  
Avant  
Vorne

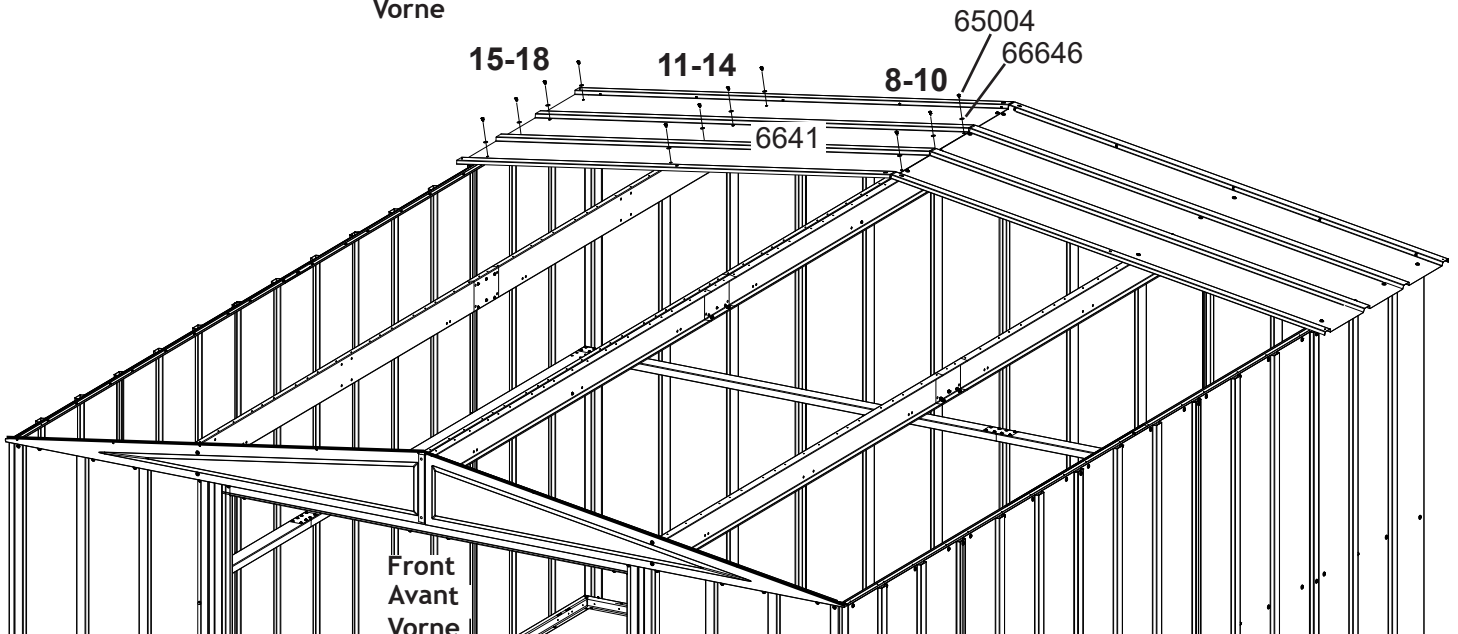

Front  
Avant  
Vorne

# 10: ROOF PANELS

PANNEAU DE TOIT  
DACHBLECH

EN,FR,GE-361C

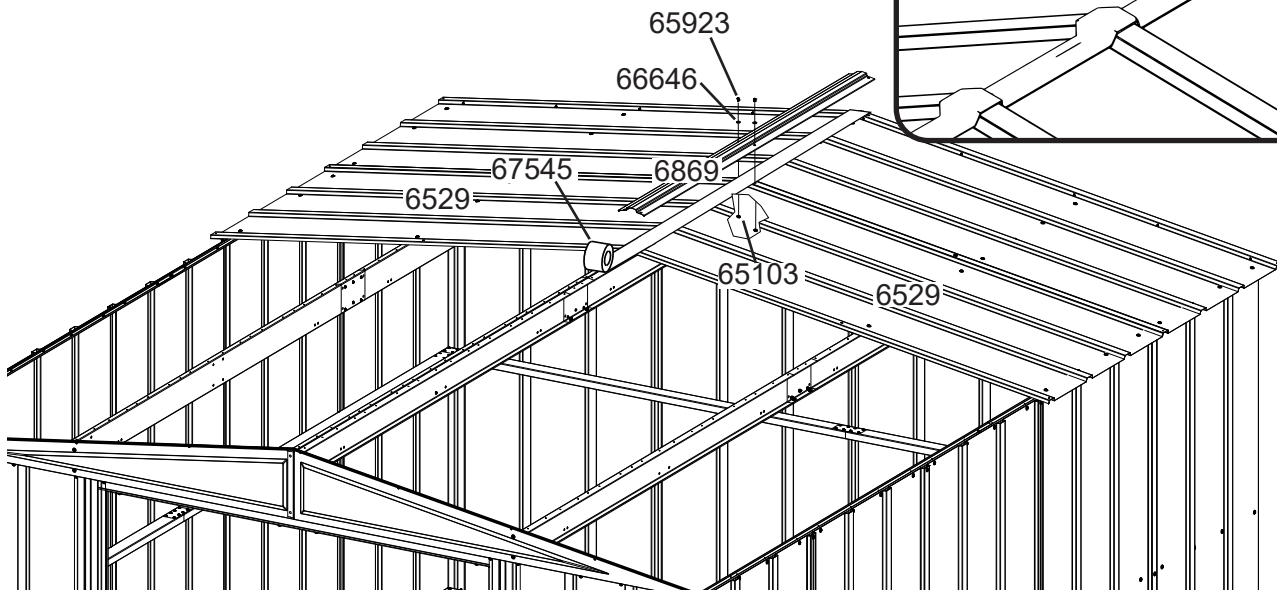
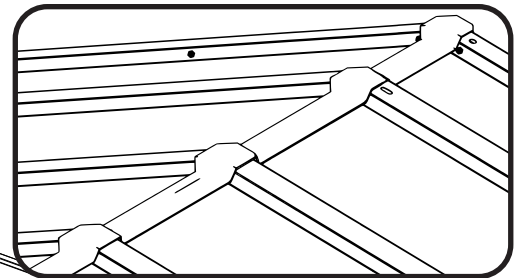
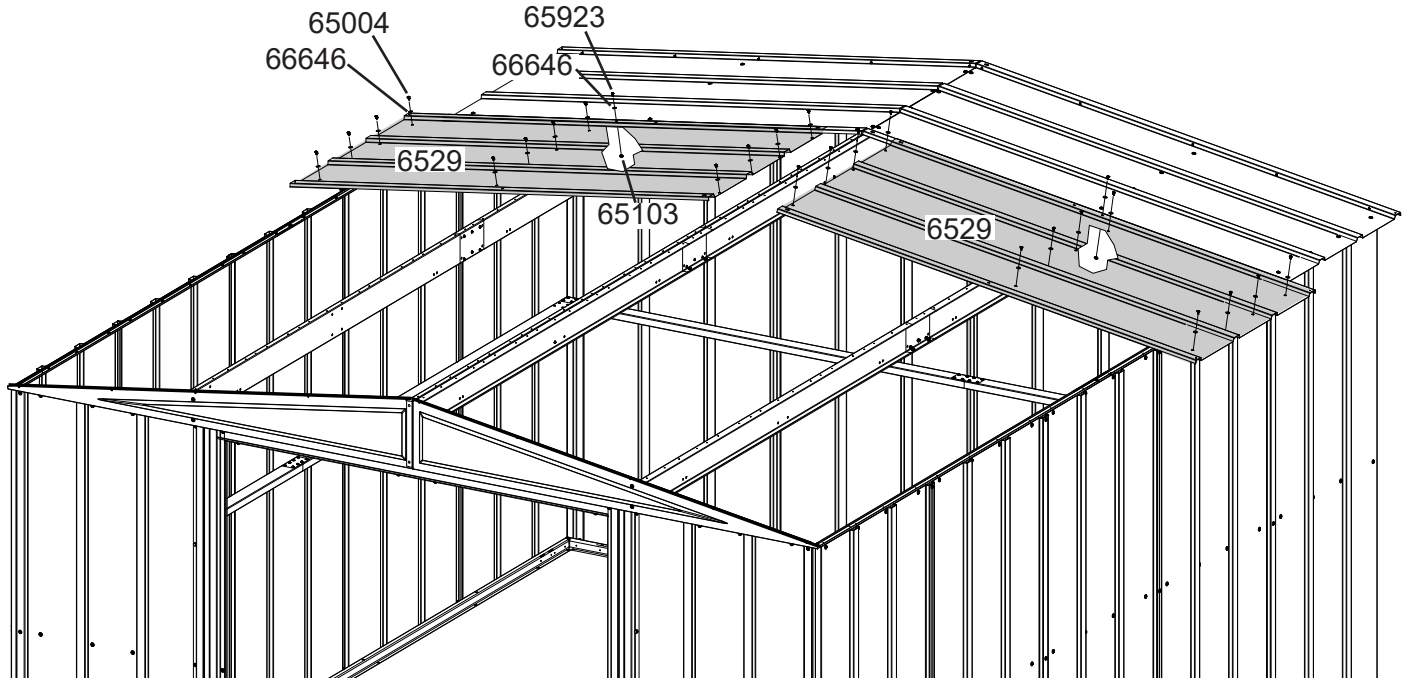
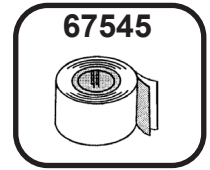
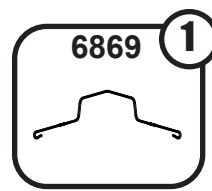
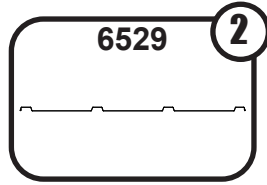
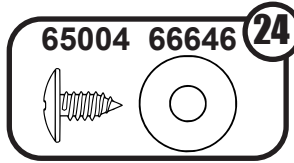
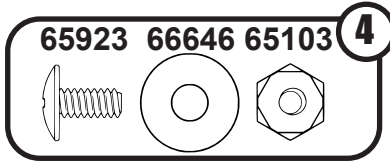

# 10: ROOF PANELS

PANNEAU DE TOIT  
DACHBLECH

EN,FR,GE-371C

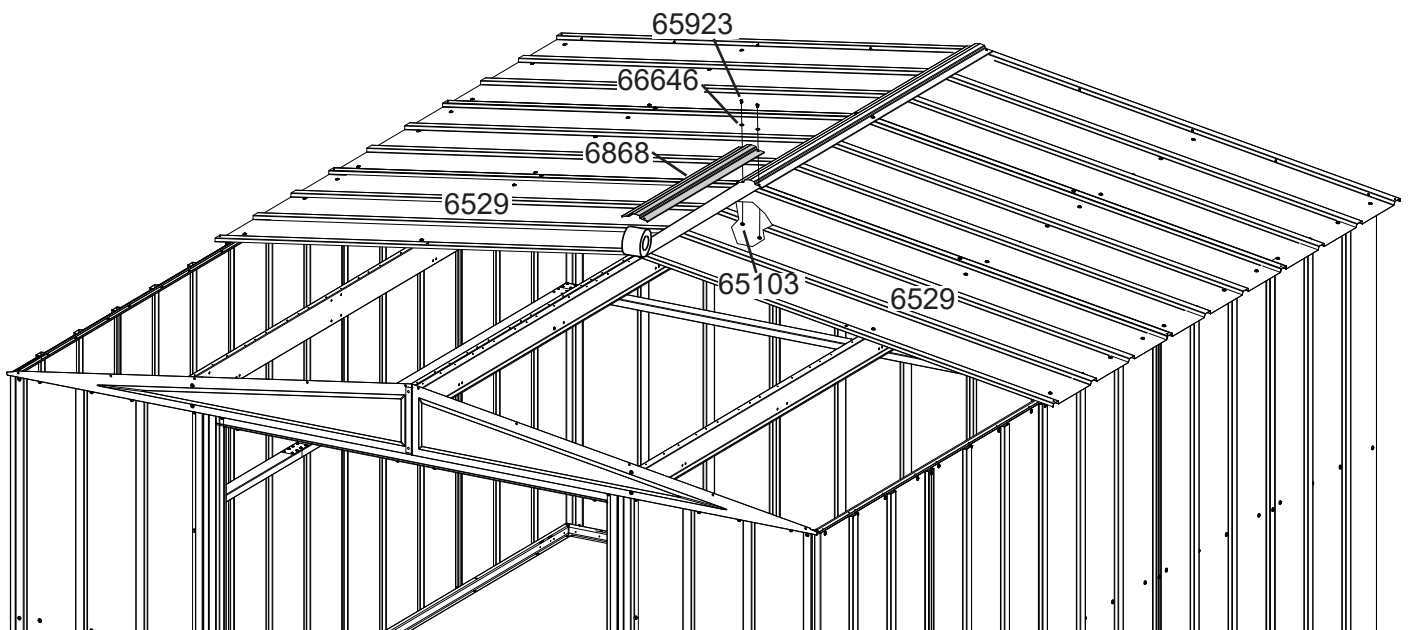
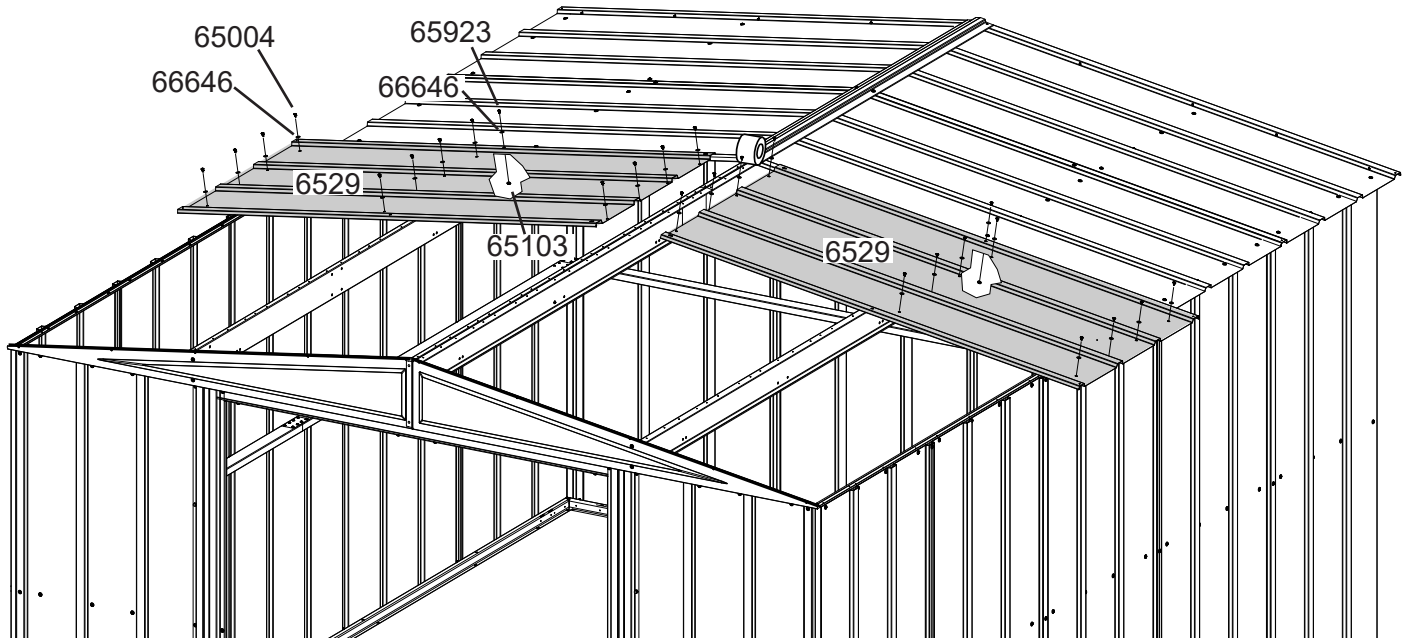
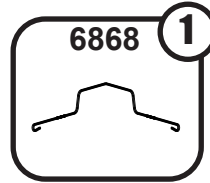
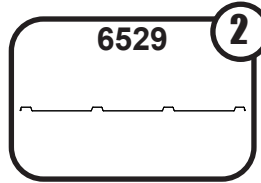
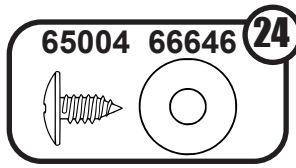
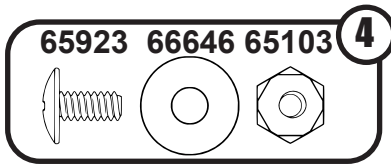

# 10: ROOF PANELS

PANNEAU DE TOIT  
DACHBLECH

EN,FR,GE-38IC

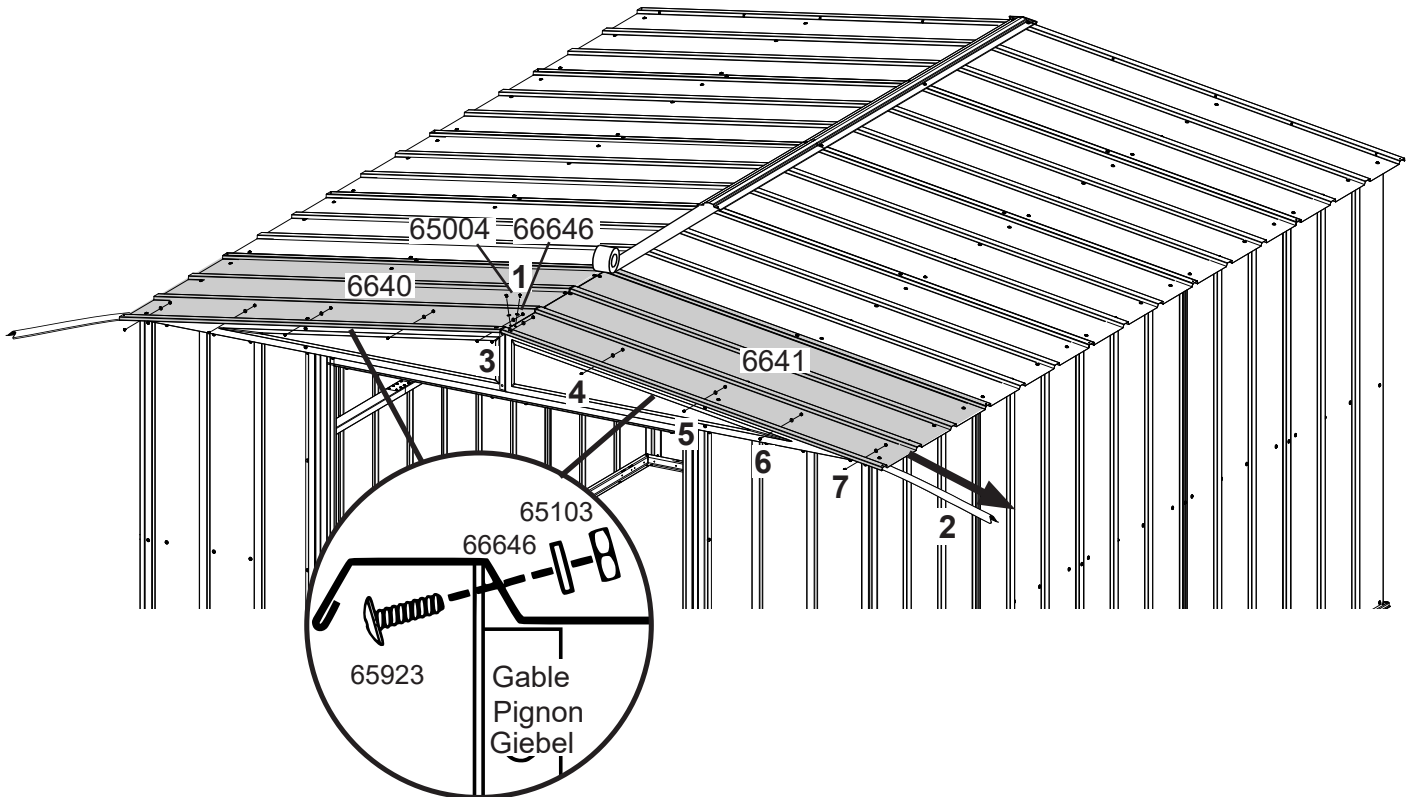
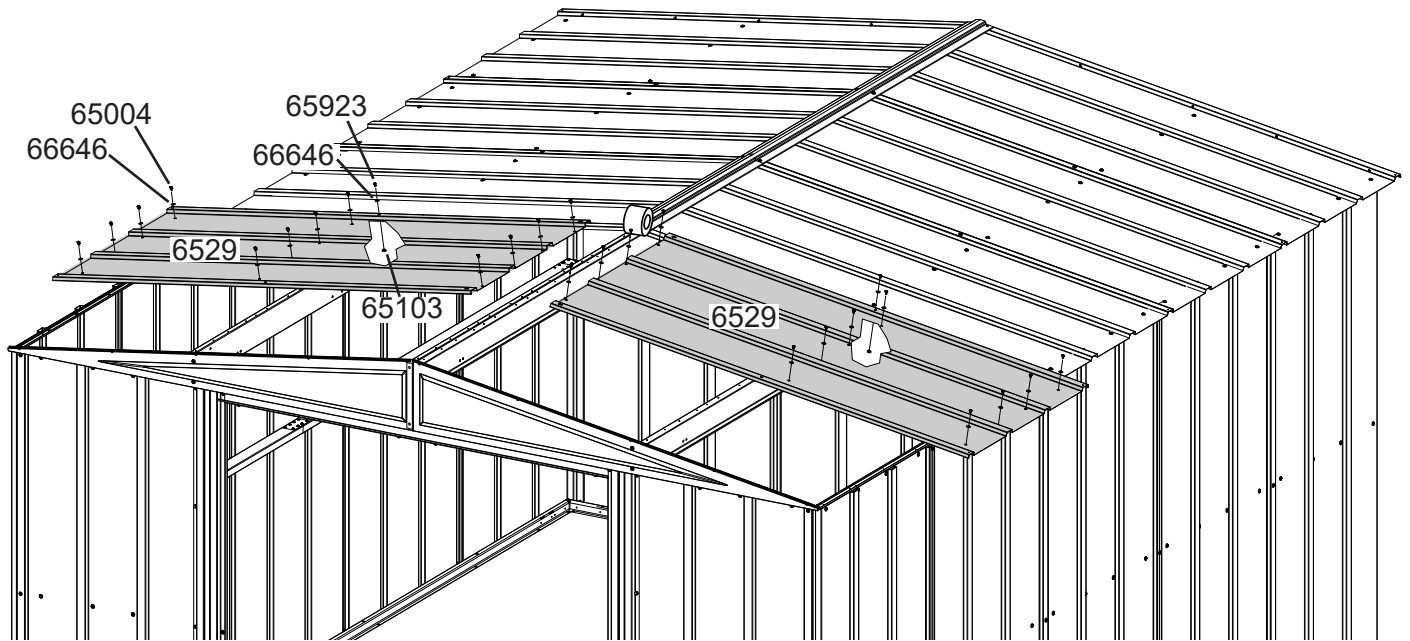
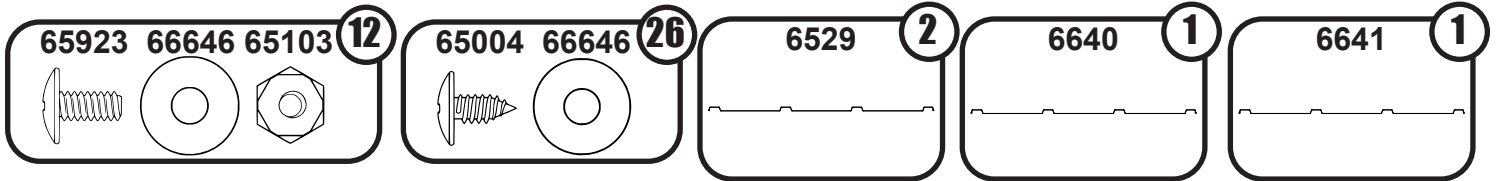

# 10: ROOF PANELS

PANNEAU DE TOIT  
DACHBLECH

EN,FR,GE-39IC

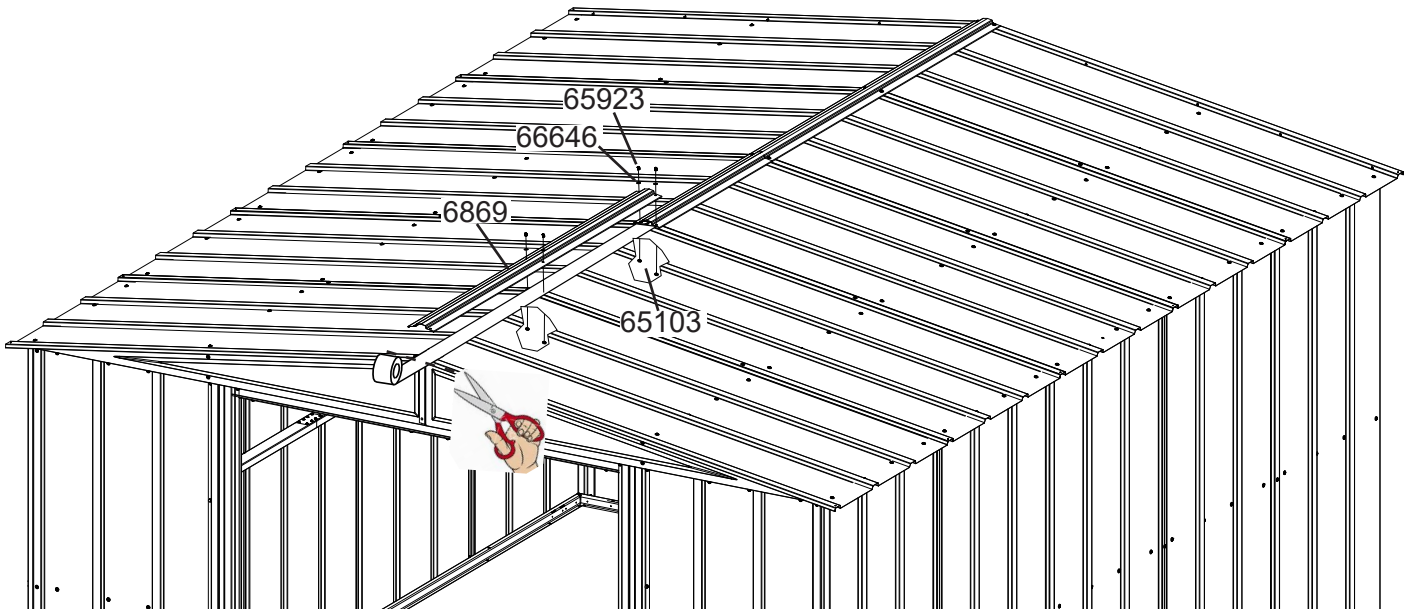
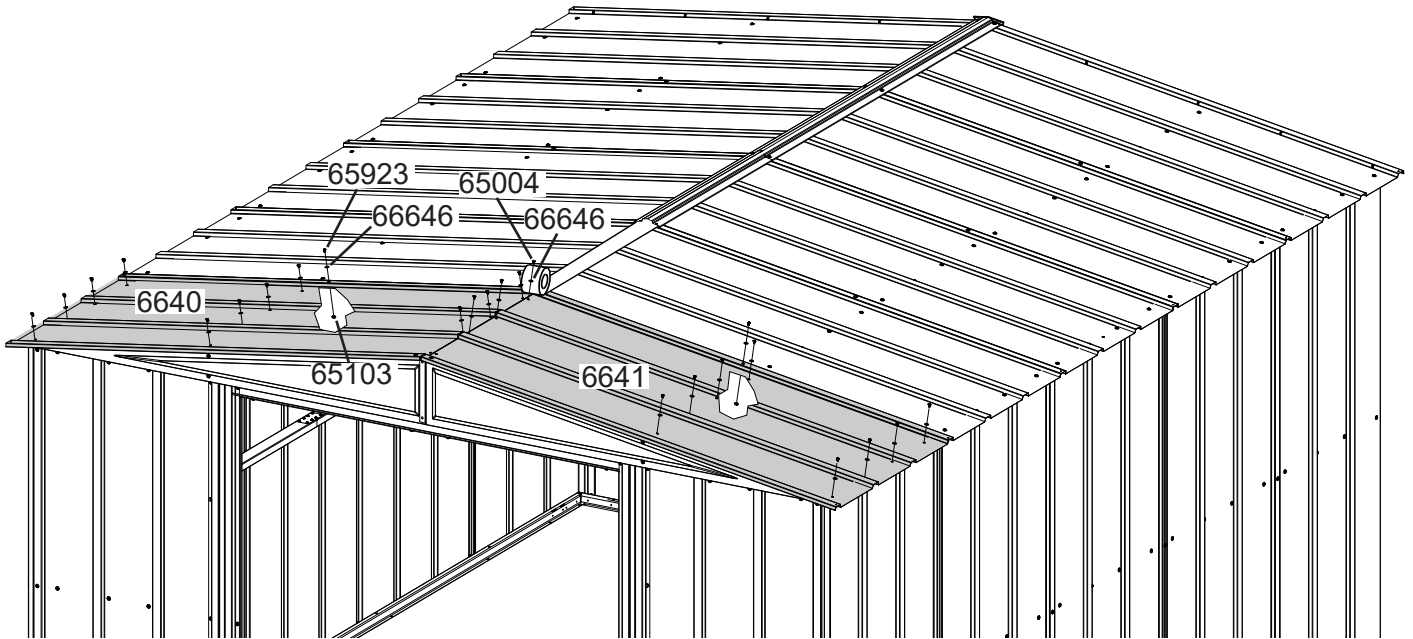
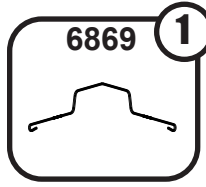
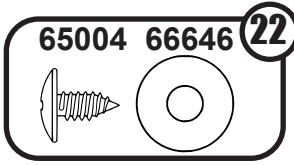
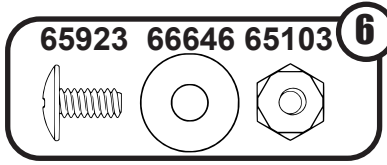

# 10: ROOF PANELS

PANNEAU DE TOIT  
DACHBLECH

EN,FR,GE-401C

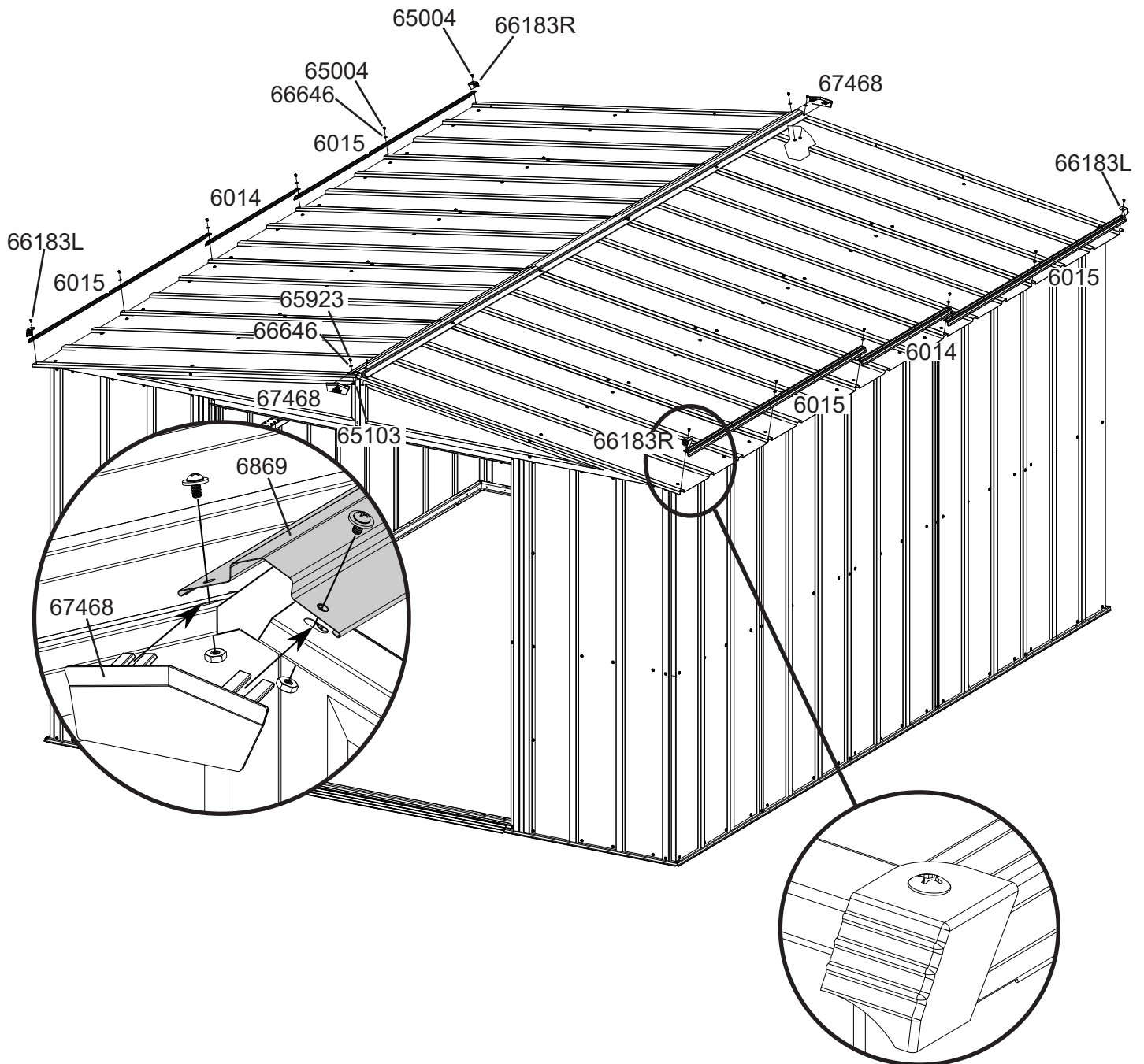
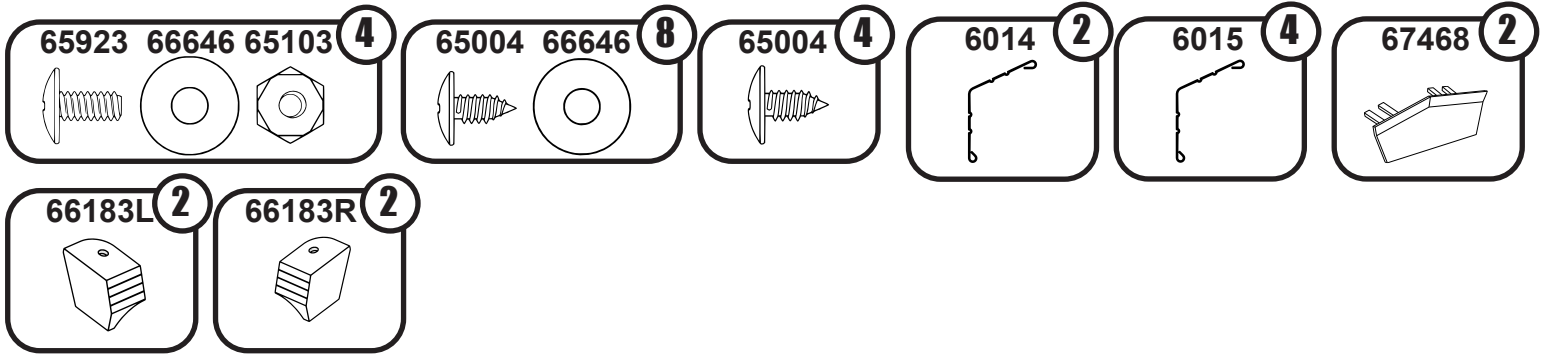



# 11: DOOR ASSEMBLY *PORTE ASSEMBLÉE* *MONTAGE DER TÜRE*

EN,FR,GE-38KA

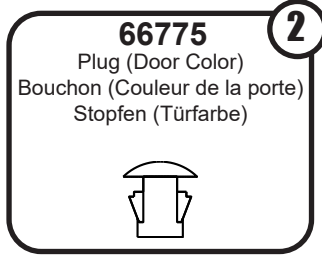
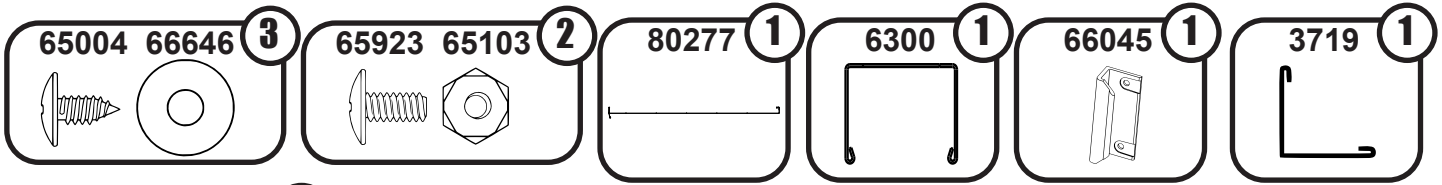

66775  
Plug (Door Color)  
Bouchon (Couleur de la porte)  
Stopfen (Türfarbe)

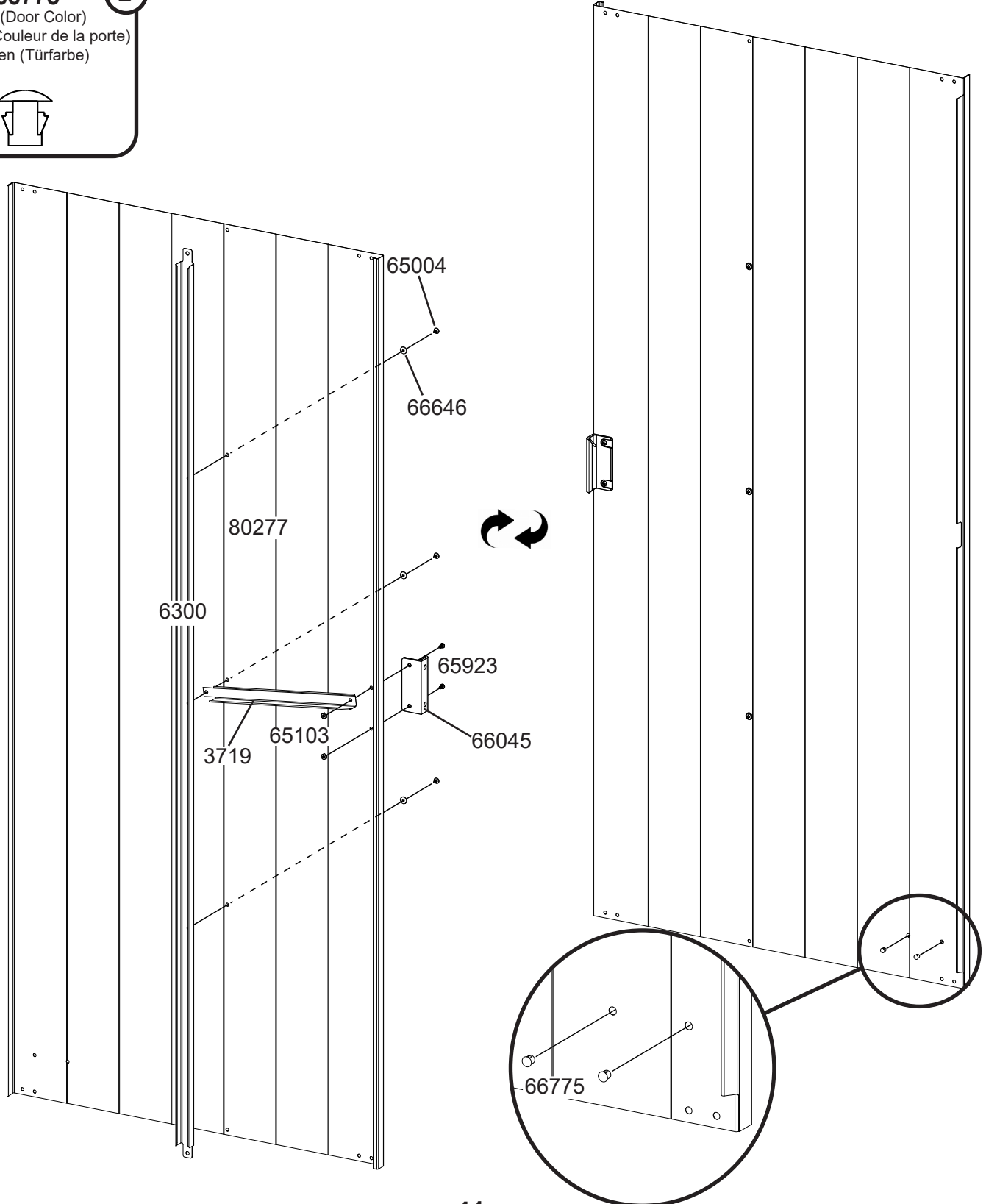

# 11: DOOR ASSEMBLY *PORTE ASSEMBLÉE* *MONTAGE DER TÜR*

EN,FR,GE-39KA

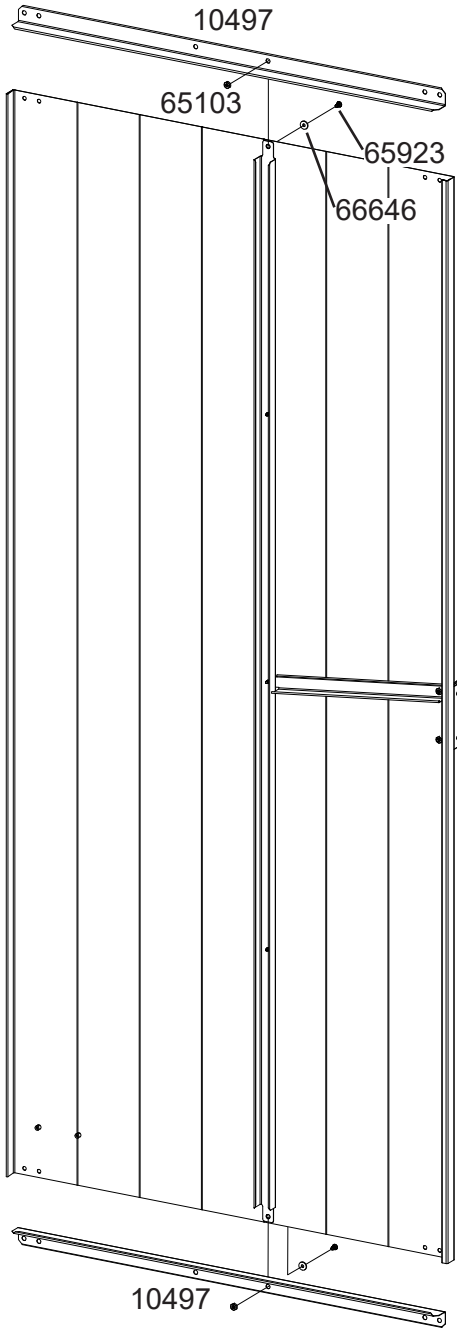
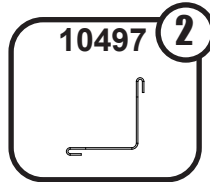
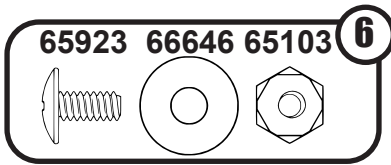

**Right Door Assembly**  
**Ensemble de porte droite**  
**Montage der rechten Tür**

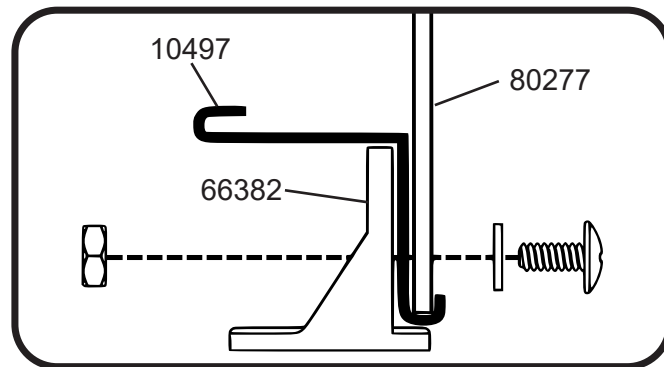
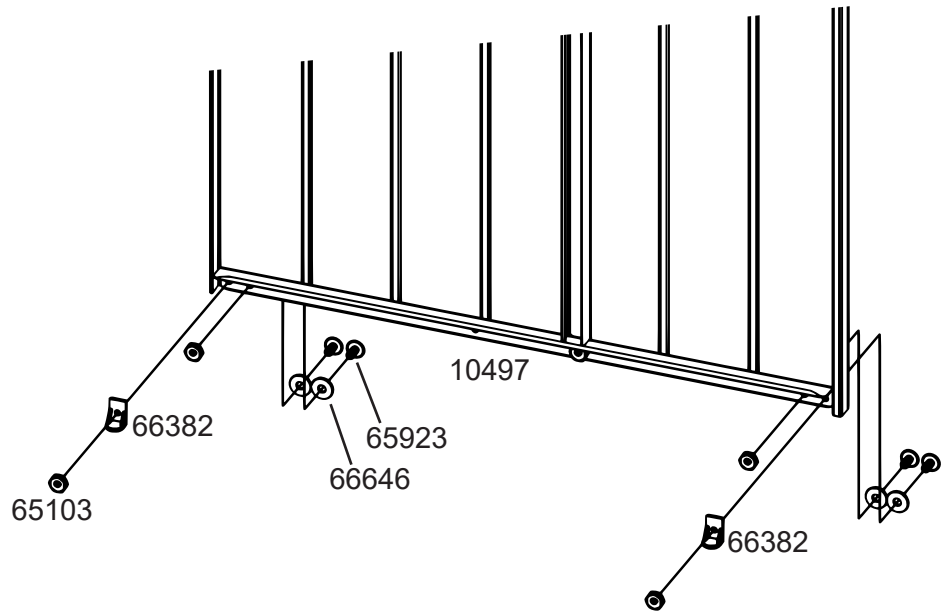

# 11: DOOR ASSEMBLY *PORTE ASSEMBLÉE* *MONTAGE DER TÜR*

EN,FR,GE-40KA

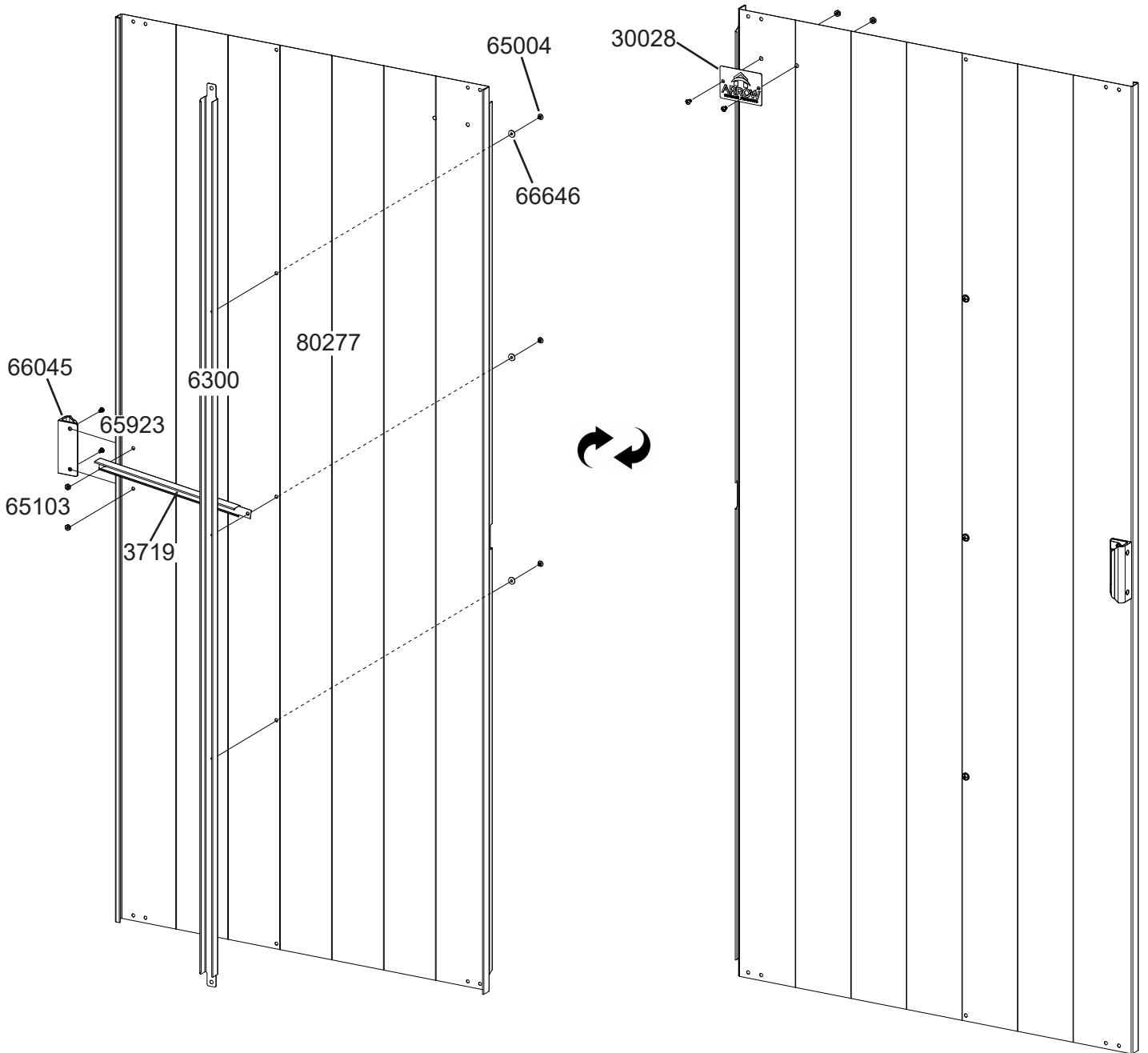
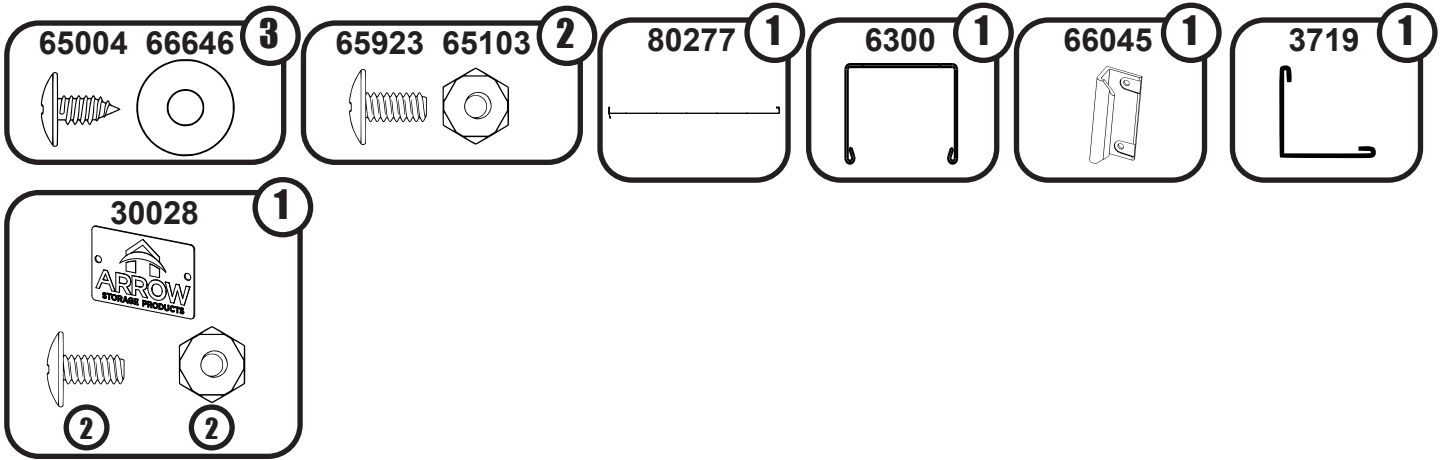

# 11: DOOR ASSEMBLY *PORTE ASSEMBLÉE* *MONTAGE DER TÜR*

EN,FR,GE-41KA

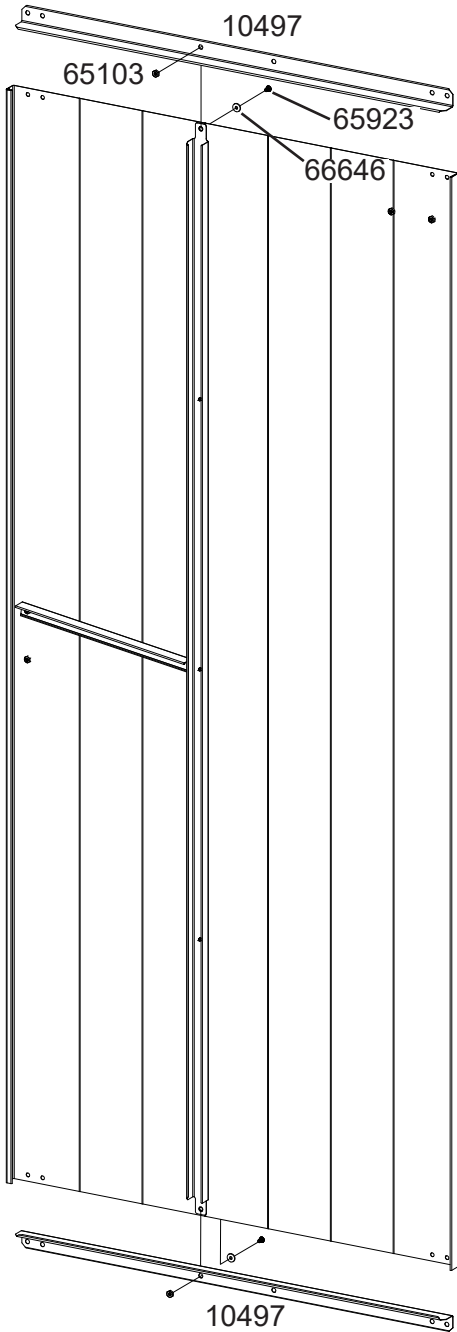
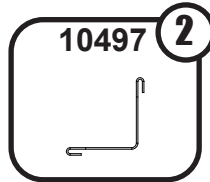
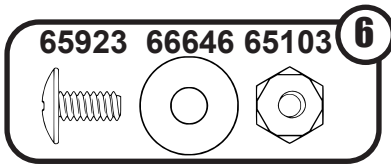

## Left Door Assembly *Ensemble de porte gauche* *Montage der linken Tür*

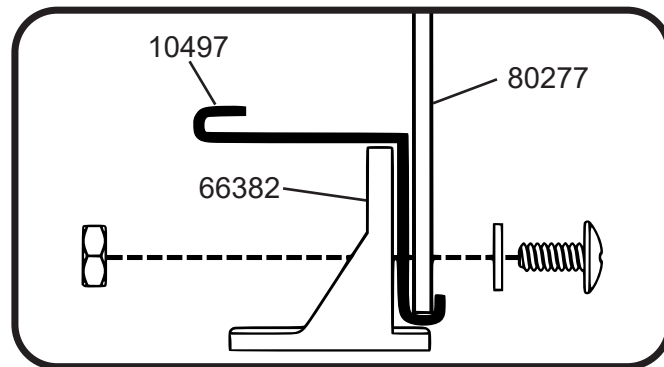
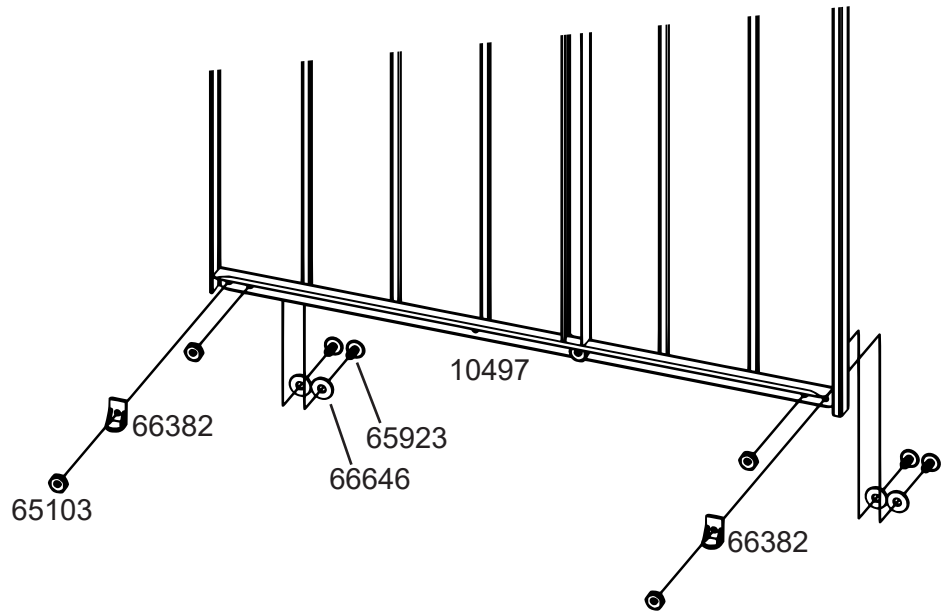

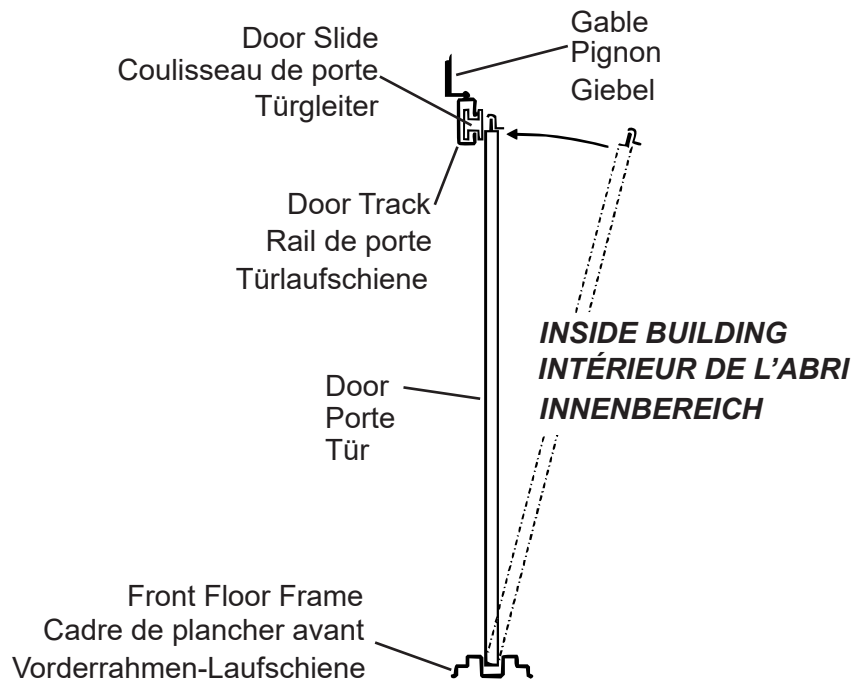
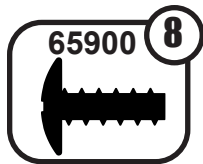

## Door Adjustment Réglage de la porte Ausrichtung der Türe

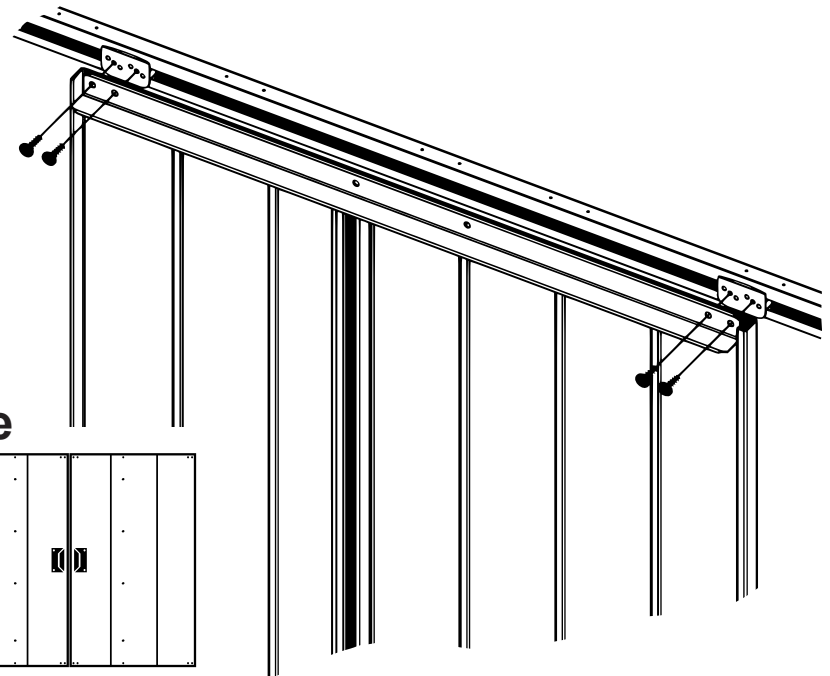

If Doors do not align, raise or lower one side of the Door by placing the Door screws through a different set of holes in the Door Slide.

Si les portes ne sont pas alignées, relever ou abaisser l'un des côtés de la porte en plaçant les vis de porte à travers un jeu de trous différents dans le coulisseau.

Falls die Türen nicht richtig ausgerichtet sind, können Sie eine Seite der Tür anheben oder absenken, indem Sie die Türschrauben in den anderen Bohrungen des Türschlittens anbringen.

## **\* IMPORTANT \***

- *If you have swing doors, they must hang and swing level before anchoring building.*
- *Anchor your building at this time. Use appropriate 1/4"(6mm) X 1 1/2"(38,1mm) length hardware.*
- *Please take a moment to ensure that the building is installed in accordance with these instructions and with all applicable regulations.*
- *The entire floor frame MUST be securely anchored once the building is erected.*

## **\* IMPORTANT \***

- *Si l'abri comporte des portes battantes, vérifier qu'elles sont accrochées de niveau et pivotent librement avant d'ancrer l'ouvrage.*
- *Ancrez votre bâtiment en ce moment. Utilisez une longueur appropriée de 1/4 po (6 mm) X 1 1/2 po (38,1 mm) Matériel.*
- *Veiller à bien s'assurer que l'abri est installé conformément aux présentes instructions et à toute la réglementation en vigueur.*
- *Le cadre de plancher entier doit IMPÉRATIVEMENT être solidement ancré une fois que l'abri est assemblé.*

## **\*WICHTIG\***

- *Wenn Sie Schwingtüren haben, müssen diese sauber hängen und schwingen, bevor der Schuppen verankert wird.*
- *Verankern Sie Ihr Gebäude zu diesem Zeitpunkt. Verwenden Sie angemessene Teile der Länge 1/4"(6mm) X 1 1/2" (38,1mm).*
- *Bitte überprüfen Sie noch einmal, ob der Schuppen im Einklang mit dieser Anleitung und mit allen geltenden Vorschriften aufgestellt wurde.*
- *Nach Aufstellung des Geräteschuppens MUSS der gesamte Bodenrahmen sicher verankert werden.*

